

S-2 SURFACE

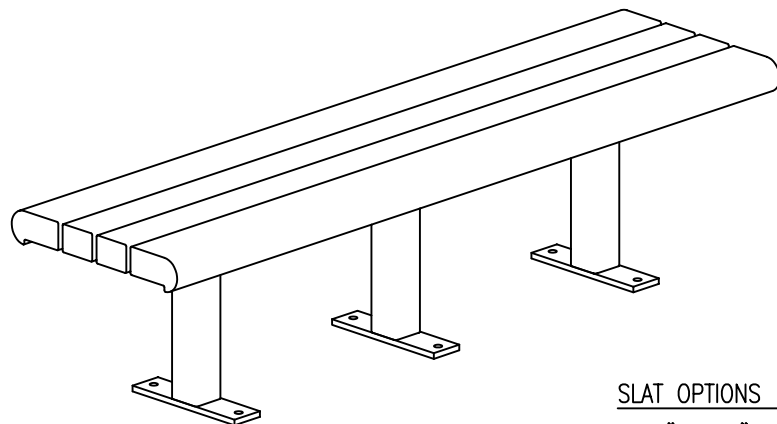

SLAT OPTIONS

- "CEDAR" RECYCLED PLASTIC
- "GREEN" RECYCLED PLASTIC
- "GREY" RECYCLED PLASTIC
- "REDWOOD" RECYCLED PLASTIC
- "WALNUT" RECYCLED PLASTIC
- OTHER _____

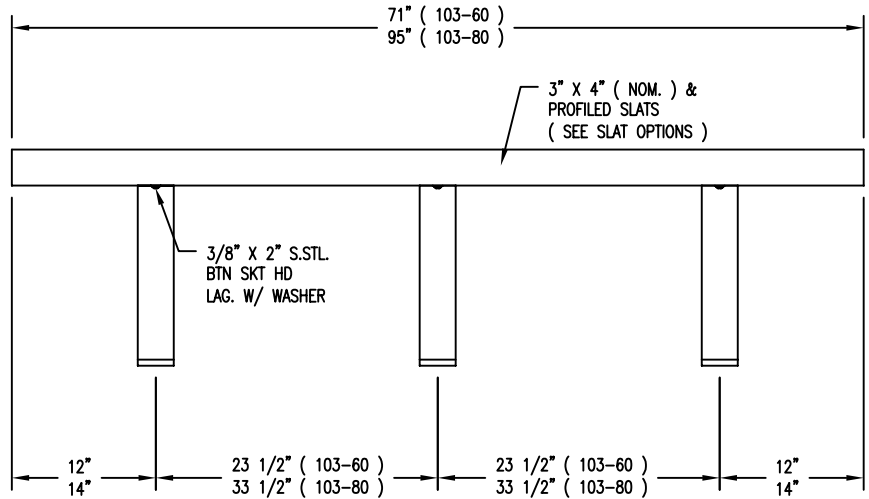
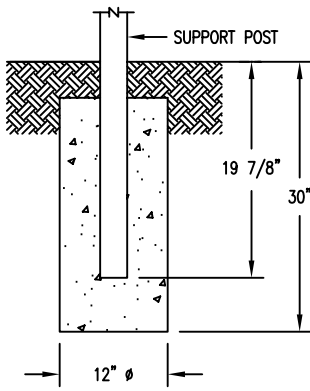

S-1 EMBEDMENT

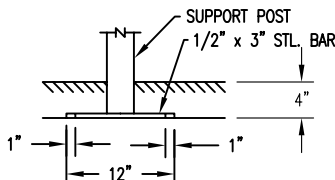

S-4 SUB FLOOR

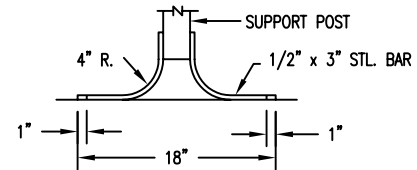

S-3 GULL WING

NOTES

- 1.) ALL STL. MEMBERS COATED W/ ZINC RICH EPOXY THEN FINISHED W/ POLYESTER POWDER COATING.
- 2.) 1/2" X 3 3/4" EXPANSION ANCHOR BOLTS PROVIDED FOR S-2, S-3 & S-4 OPTIONS.

LENGTH OPTIONS

- 6' BENCH
- 8' BENCH

DuMor, inc.
P.O. Box 142 Mifflintown, PA 17059-0142

SCALE :	NONE
DATE DRAWN :	12/12/96
DRAWN BY :	AH
DATE REV. :	12/03/09
REV. BY :	ESS

TITLE :	BENCH		
REV. :	C	DRAWING NUMBER :	103 SERIES PL
			SHEET : 1 OF 2

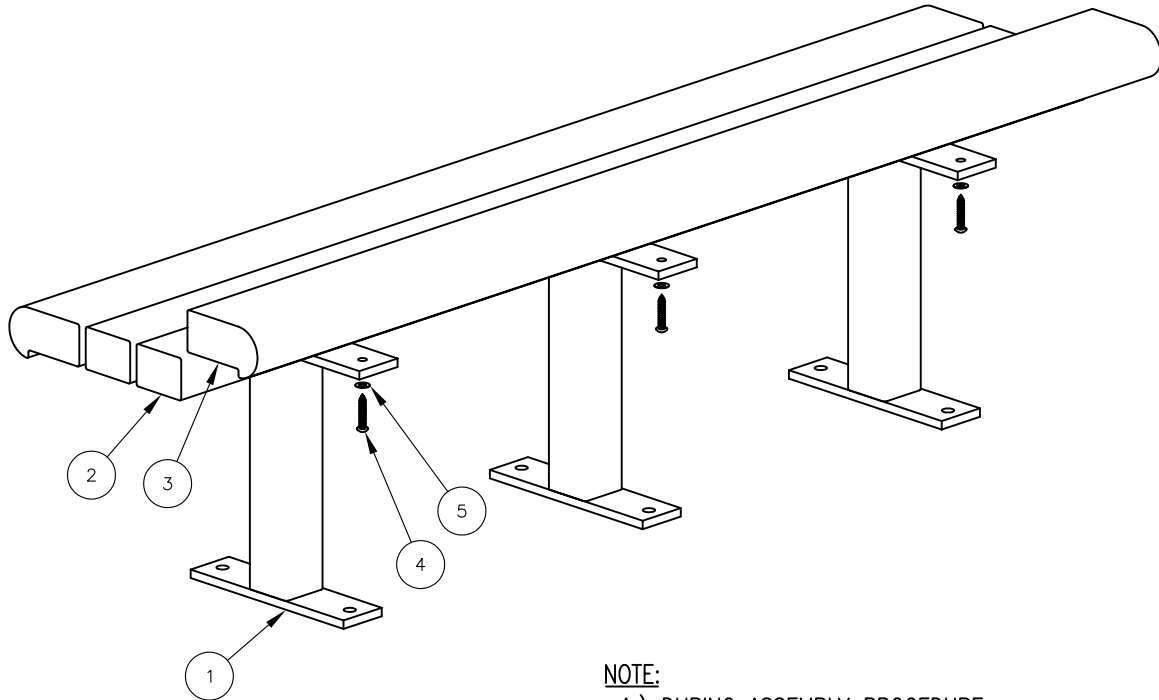

NOTE:

- 1.) DURING ASSEMBLY PROCEDURE;
DO NOT COMPLETELY TIGHTEN HARDWARE.
- 2.) THE ACTUAL PARTS WILL NOT BE NUMBERED:
NUMBERS ONLY APPLY TO DRAWING.
- 3.) SEE SPEC. SHEET 1 FOR MOUNTING OPTIONS.

STEP 1:

- USE 3 - PCS. SUPPORT FOR SURFACE MOUNT (1)
- 2 - PCS. 3" X 4" X 71" PLASTIC INT'R SLAT (2)
- 2 - PCS. 71" PLASTIC EDGE SLAT (3)
- 12 - PCS. 3/8" X 2" SS. BTN. SKT. HD. LAG SCR. (4)
- 12 - PCS. 3/8" SS. FLAT WASHER (5)

ATTACH SLATS (2 & 3) TO SUPPORT FOR SURFACE MOUNT (1) USING HARDWARE (4 & 5). TIGHTEN TO SNUG FIT. REPEAT UNTIL ALL SLATS ARE ATTACHED.

STEP 2:

UPON COMPLETION OF BENCH ASSEMBLY SQUARE ALL COMPONENTS THEN TIGHTEN ALL HARDWARE.

STEP 3:

ANCHOR ACCORDING TO SUPPORT OPTION USED.

ITEM	QTY	PART NO	DESCRIPTION
1	3	0-103-00-01/S-2	SUPPORT FOR SURFACE MOUNT
2	2	0-88-60PL-02	3" X 4" X 71" PLASTIC INT'R SLAT
3	2	0-88-60PL-03	71" PLASTIC EDGE SLAT
4	12	1-13-016	3/8" X 2" SS BTN SKT HD LAG SCR
5	12	1-22-024	3/8" SS FLAT WASHER

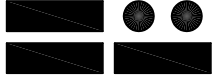
 DuMor, inc. P.O. Box 142 Mifflintown, PA 17059-0142	SCALE :	NONE	TITLE : BENCH ASSEMBLY	
	DATE DRAWN :	12/15/96		
	DRAWN BY :	AH	REV. : C DRAWING NUMBER : 103 SERIES PL	SHEET 2 OF 2
	DATE REV. :	12/03/09		
	REV. BY :	ESS		