

ALL WELDS CONT.
THEN GROUND SMOOTH

1/4" X 1 1/2"
STL. BAR
(24 REQ'D)

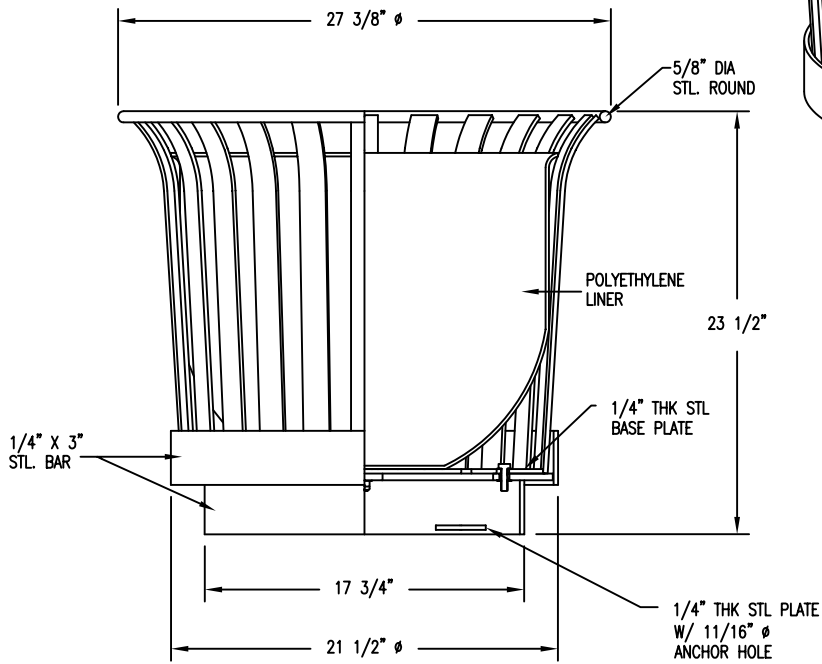
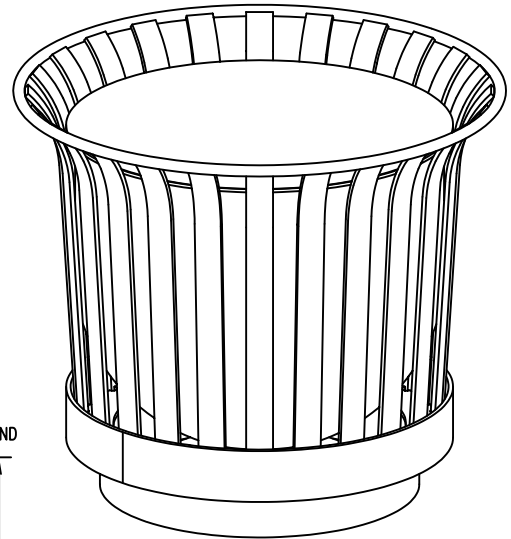

NOTES:

- 1.) ALL STL. MEMBERS COATED W/ ZINC RICH EPOXY THEN FINISHED W/ POLYESTER POWDER COATING.
- 2.) 1/2" X 3 3/4" EXPANSION ANCHOR BOLTS PROVIDED.
- 3.) ALL WELDS CONTINUOUS THEN GROUNDED SMOOTH.

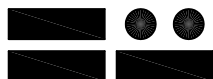

DuMor, inc.

P.O. Box 142 Mifflintown, PA 17059-0142

SCALE :	NONE
DATE DRAWN :	9/10/99
DRAWN BY :	HD
DATE REV. :	8/27/08
REV. BY :	AWH

TITLE :	PLANTER		
REV.	DRAWING NUMBER	114-00	SHEET
E			1 OF 2

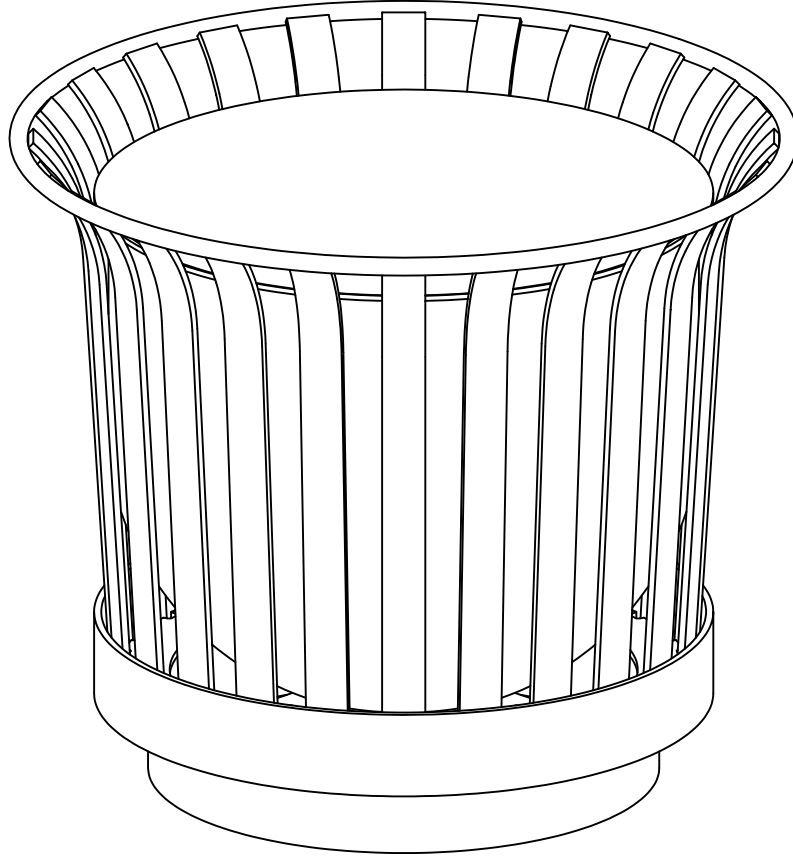

NOTE:

- 1.) SHIPPED FULLY ASSEMBLED.
- 2.) MOUNT AND ANCHOR AS SPECIFIED.



DuMor, inc.

P.O. Box 142 Mifflintown, PA 17059-0142

SCALE :	NONE
DATE DRAWN :	9/10/99
DRAWN BY :	HD
DATE REV. :	8/27/08
REV. BY :	AWH

TITLE :	PLANTER ASSEMBLY	
REV.	DRAWING NUMBER	SHEET
E	114-00	2 OF 2