

**NOTES**

- 1.) ALL STL. MEMBERS COATED W/ ZINC RICH EPOXY THEN FINISHED W/ POLYESTER POWDER COATING.
- 2.) 1/2" X 3 3/4" EXPANSION ANCHOR BOLTS PROVIDED FOR S-2 & S-4 OPTIONS.

**LENGTH OPTIONS**

- 6' BENCH
- 8' BENCH

<p><b>DuMor, inc.</b> P.O. Box 142 Mifflintown, PA 17059-0142</p>	SCALE :	NONE	TITLE :		BENCH	
	DATE DRAWN :	9/20/01	REV.	DRAWING NUMBER	137 SERIES	SHEET 1 OF 2
	DRAWN BY :	AWH	C			
	DATE REV. :	6/4/09				
REV. BY :	AWH					

SURFACE MOUNT OPTION SHOWN.

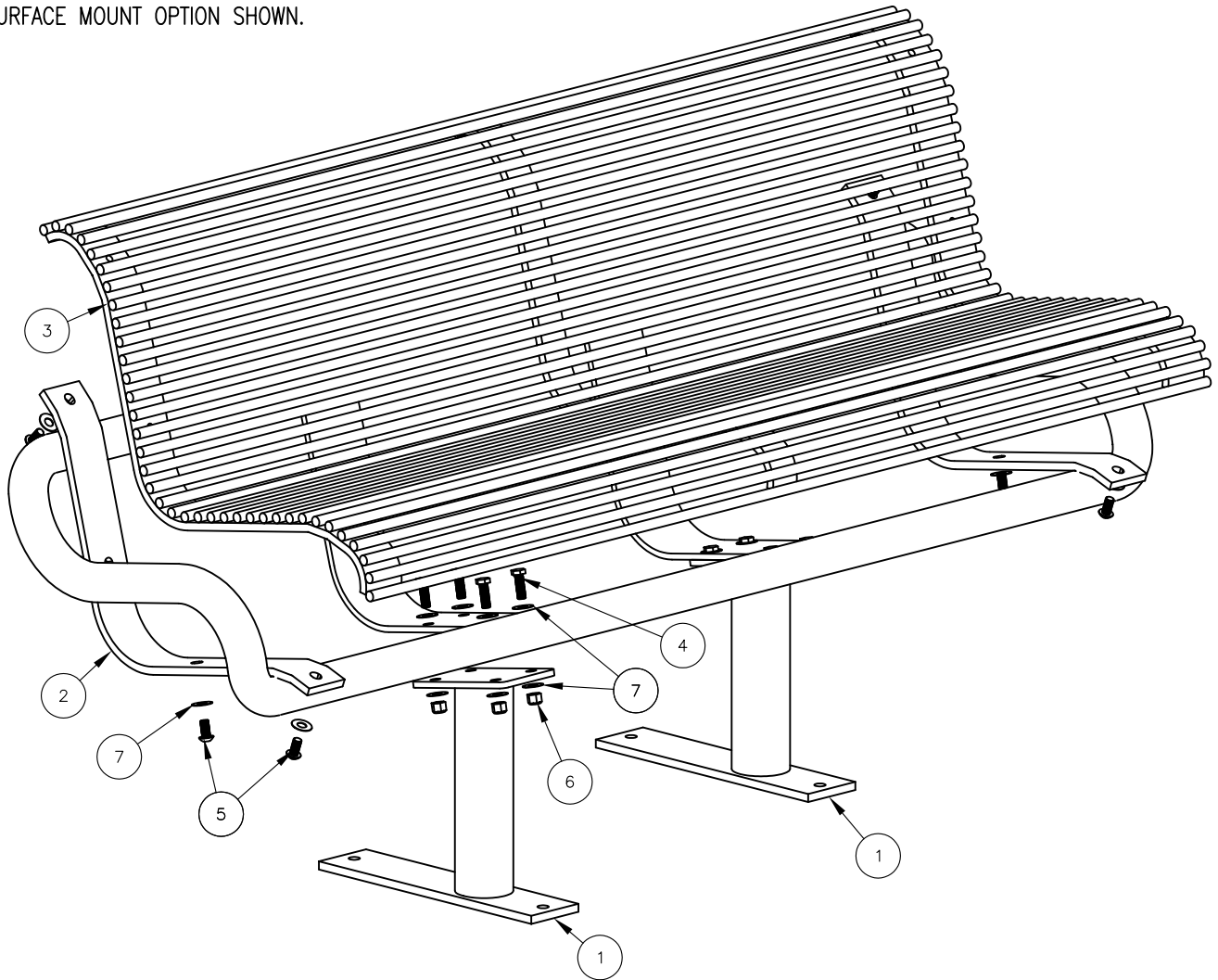

**STEP 1:**

- USE 2 - PCS. SUPPORT FOR SURFACE MOUNT ( 1 )
  - 1 - PC. 6' ALL STL. BENCH FRAME ( 2 )
  - 8 - PCS. 1/2" X 1 1/2" SS. HEX HD. CAP SCREW ( 4 )
  - 8 - PCS. 1/2" SS. NYLON LOCKNUT ( 6 )
  - 16 - PCS. 1/2" SS. FLAT WASHER ( 7 )
- ATTACH SUPPORT FOR SURFACE MOUNT ( 1 ) TO 6' ALL STL. BENCH FRAME ( 2 ) USING HARDWARE ( 4, 6, & 7 ). SQUARE ALL COMPONENTS THEN TIGHTEN ALL HARDWARE.

**STEP 2:**

- USE 1 - PC. 6' STL. SEAT ASSEMBLY ( 3 )
  - 8 - PCS. 1/2" X 1" SS. BTN SKT HD CAP SCREW ( 5 )
  - 8 - PCS. 1/2" SS. FLAT WASHER ( 7 )
- ATTACH 6' STL. SEAT ASSEMBLY ( 3 ) TO STEP 1 ASSEMBLY USING HARDWARE ( 5, & 7 ). TIGHTEN ALL HARDWARE.

**NOTE:**

- 1.) DURING ASSEMBLY PROCEDURE; TIGHTEN HARDWARE UPON COMPLETION OF EACH INDIVIDUAL STEP.
- 2.) THE ACTUAL PARTS WILL NOT BE NUMBERED: NUMBERS ONLY APPLY TO DRAWING.
- 3.) SEE SPEC. SHEET 1 FOR MOUNTING OPTION.

**STEP 3:**

ANCHOR ACCORDING TO SUPPORT OPTION USED.

ITEM	QTY	PART NO	DESCRIPTION
1	2	0-136-02/S-2	STL SUPPORT FOR SURFACE MOUNT
2	1	0-136-60-01	6' STL BENCH FRAME
3	1	0-137-60-01	6' STL SEAT
4	8	1-12-004	1/2" X 1 1/2" SS HEX HD CAP SCR
5	8	1-12-056	1/2" X 1" SS BTN SKT HD CAP SCR
6	8	1-20-015	1/2" SS NYLON LOCKNUT
7	24	1-22-015	1/2" SS FLAT WASHER



**DuMor, inc.**  
P.O. Box 142 Mifflintown, PA 17059-0142

SCALE : NONE  
DATE DRAWN : 9/20/01  
DRAWN BY : AWH  
DATE REV. : 6/4/09  
REV. BY : AWH

TITLE : BENCH ASSEMBLY

REV. C	DRAWING NUMBER 137 SERIES	SHEET 2 OF 2
--------	---------------------------	--------------