

S-2 SURFACE MT

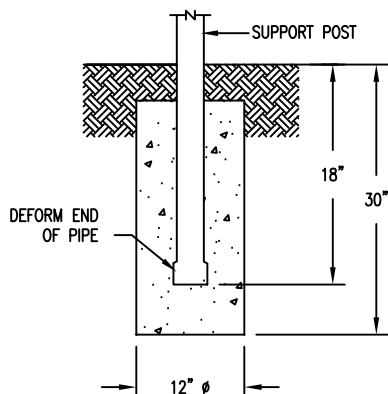

S-1 EMBEDMENT

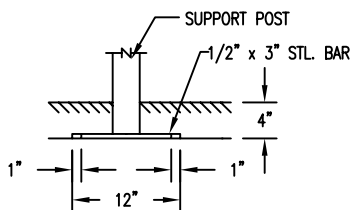

S-4 SUB FLOOR

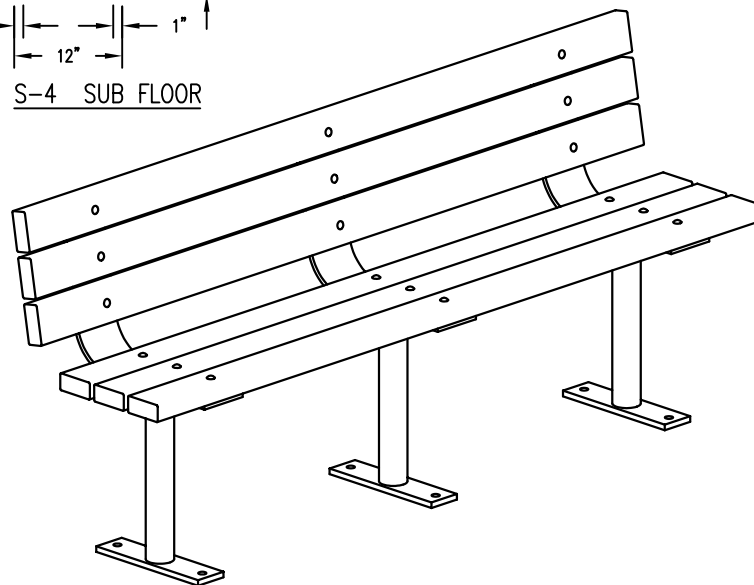

LENGTH OPTIONS

- 6' BENCH
- 8' BENCH

SLAT OPTIONS

- "CEDAR" RECYCLED PLASTIC
- "GREY" RECYCLED PLASTIC
- "GREEN" RECYCLED PLASTIC
- "REDWOOD" RECYCLED PLASTIC
- "WALNUT" RECYCLED PLASTIC
- OTHER _____

NOTES

- 1.) ALL STL. MEMBERS COATED W/ ZINC RICH EPOXY THEN FINISHED W/ POLYESTER POWDER COATING.
- 2.) 1/2" X 3 3/4" EXPANSION ANCHOR BOLT PROVIDED FOR S-2 & S-4 OPTIONS.



DuMor, inc.

P.O. Box 142 Mifflintown, PA 17059-0142

SCALE : NONE
DATE DRAWN : 9/20/01
DRAWN BY : AWH
DATE REV. : 12/2/09
REV. BY : JSB

TITLE : BENCH
REV. B

BENCH

DRAWING NUMBER

138 SERIES PL

SHEET 1 OF 2

SURFACE MOUNT
S-2 OPTION SHOWN

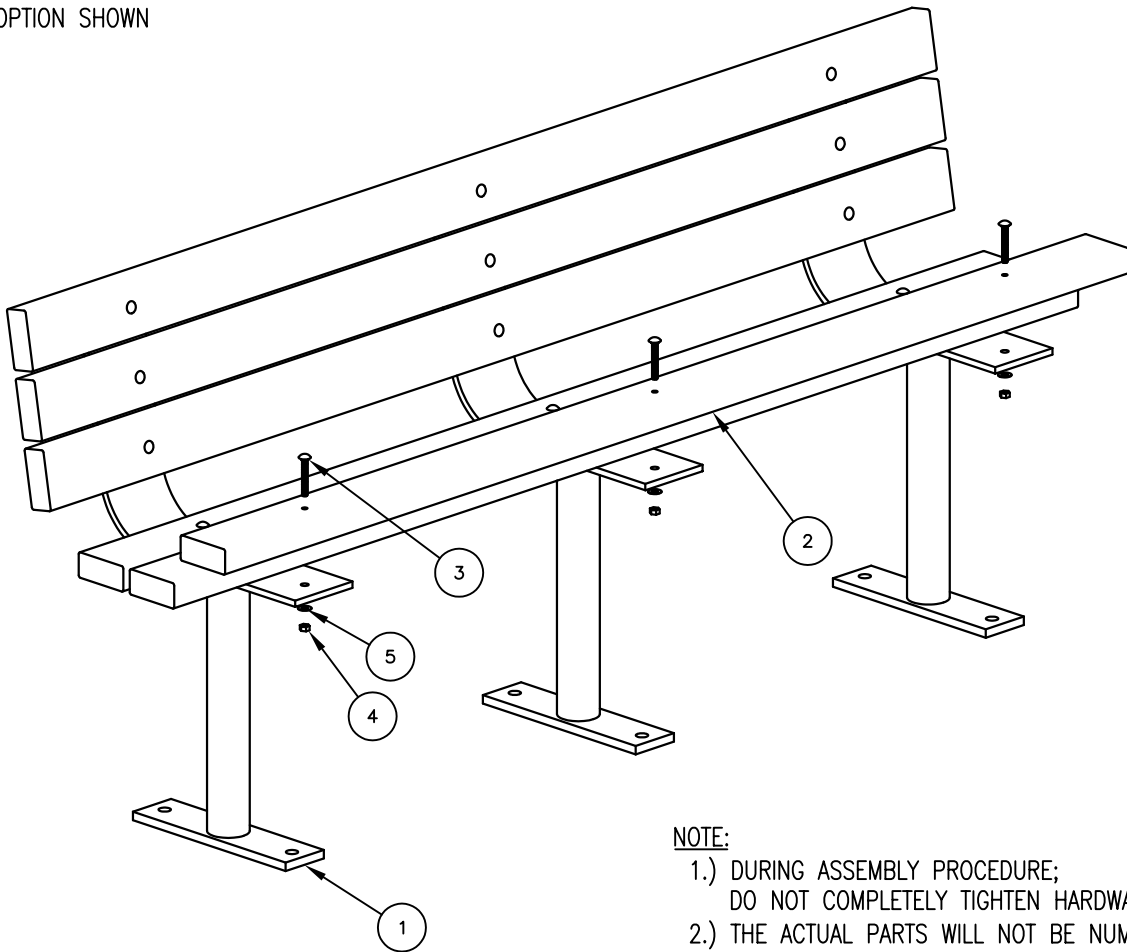

NOTE:

- 1.) DURING ASSEMBLY PROCEDURE;
DO NOT COMPLETELY TIGHTEN HARDWARE.
- 2.) THE ACTUAL PARTS WILL NOT BE NUMBERED:
NUMBERS ONLY APPLY TO DRAWING.
- 3.) SEE SPEC. SHEET 1 FOR MOUNTING OPTIONS.

STEP 1:

- USE 3 - PC. SUPPORT POST (1)
 18 - PCS. 5/16" X 2 1/4" SS CGE BOLT (3)
 18 - PCS. 5/16" SS HEX NUT (4)
 18 - PCS. 5/16" SS FLAT WASHER (5)
 6 - PC. 2" X 4" X 71" PLASTIC SLAT (2)

ATTACH ONE PLASTIC SLAT (2) TO THREE SUPPORT POSTS (1)
 USING HARDWARE (3, 4 & 5). TIGHTEN TO SNUG FIT. REPEAT
 UNTIL ALL PLASTIC SLATS ARE ATTACHED TO SUPPORT POSTS.

STEP 2:

UPON COMPLETION OF BENCH ASSEMBLY SQUARE ALL COMPONENTS
 THEN TIGHTEN ALL HARDWARE.

STEP 3:

ANCHOR ACCORDING TO SUPPORT OPTION USED.

ITEM	QTY	PART NO	DESCRIPTION
1	3	0-138-01/S-2	SUPPORT FOR SURFACE MOUNT
2	6	0-138-60PL-02	2" X 4" X 71" RECYCLED PLASTIC SLAT
3	18	1-11-062	5/16" X 2 1/4" SS CGE BOLT
4	18	1-21-015	5/16" SS HEX NUT
5	18	1-22-017	5/16" SS FLAT WASHER



DuMor, inc.
 P.O. Box 142 Mifflintown, PA 17059-0142

SCALE : NONE
 DATE DRAWN : 9/20/01
 DRAWN BY : AWH
 DATE REV. : 12/2/09
 REV. BY : JSB

TITLE : BENCH ASSEMBLY
 REV. B
 DRAWING NUMBER 138 SERIES PL
 SHEET 2 OF 2