

LENGTH OPTIONS

- 6' BENCH
- 8' BENCH

CUSTOM LETTERING (37 SPACES) _____

NOTES

- 1.) ALL STL. MEMBERS COATED W/ ZINC RICH EPOXY THEN FINISHED W/ POLYESTER POWDER COATING.
- 2.) ALL WOOD MEMBERS TREATED W/ CLEAR PRESERVATIVE.
- 3.) 1/2" X 3 3/4" EXPANSION ANCHOR BOLTS PROVIDED.
- 4.) CUSTOM LETTERING AVAILABLE FOR RECESSED SIDE PANELS (TOTAL OF 37 SPACES).

WOOD OPTIONS

- CLEAR ALL HEART REDWOOD S4S EE
- 'C' & BTR. DOUGLAS FIR KD S4S EE
- CLEAR IPE S4S EE
- OTHER _____

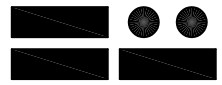
 DuMor, inc. P.O. Box 142 Mifflintown, PA 17059-0142	SCALE :	NONE	TITLE :		BENCH	
	DATE DRAWN :	7/10/01			PATENT D467-101	
	DRAWN BY :	AH	REV.	DRAWING NUMBER	142 SERIES	
	DATE REV. :	12/15/08	B			
	REV. BY :	ESS			SHEET 1 OF 2	

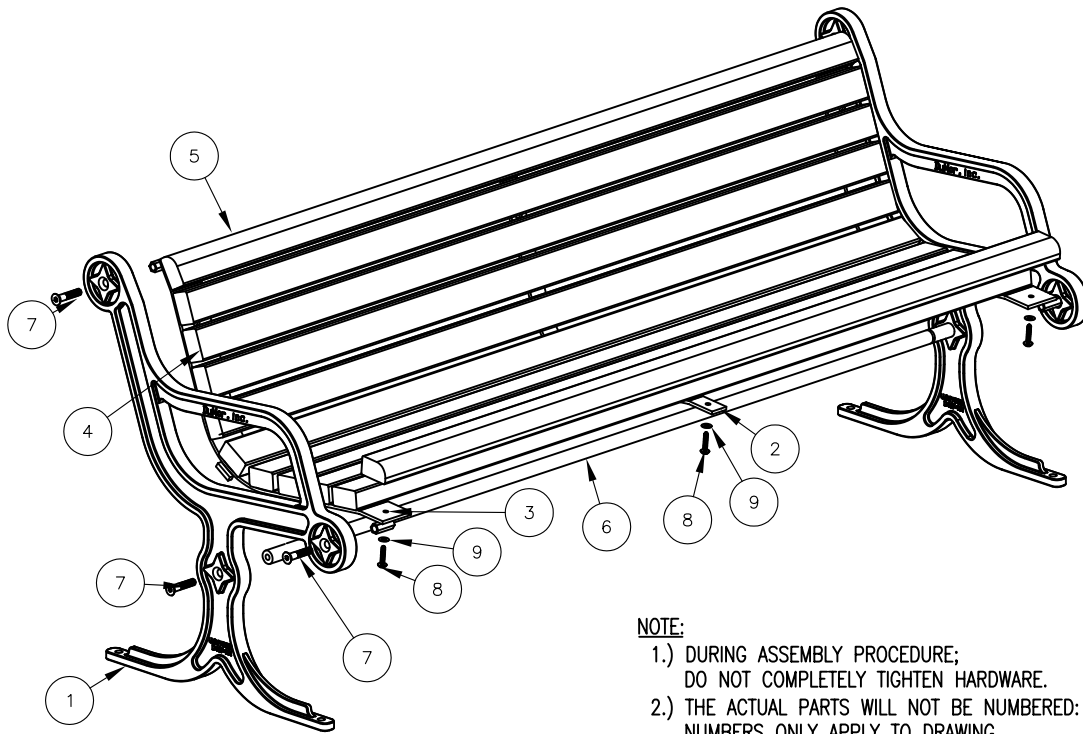

NOTE:

- 1.) DURING ASSEMBLY PROCEDURE;
DO NOT COMPLETELY TIGHTEN HARDWARE.
- 2.) THE ACTUAL PARTS WILL NOT BE NUMBERED;
NUMBERS ONLY APPLY TO DRAWING.

STEP 1:

USE 2 - PCS. CAST IRON BENCH SUPPORT (1)
 1 - PC. 71 3/4" PIPE BRACE (6)
 2 - PCS. 1/2" X 2 1/2" FLT. SKT. HD. CAP SCR. (7)
 ATTACH CAST IRON SUPPORT (1) TO 71 3/4" PIPE BRACE (6)
 USING HARDWARE (7). TIGHTEN TO SNUG FIT.

STEP 2:

USE 2 - PCS. END CONTOUR STRAP (3)
 4 - PCS. 1/2" X 2 1/2" FLT. SKT. HD. CAP SCR. (7)
 ATTACH END CONTOUR STRAPS (3) TO STEP 1 ASSEMBLY USING
 HARDWARE (7). TIGHTEN TO SNUG FIT.

STEP 3:

USE 9 - PCS. 2" X 3" X 71" WOOD INT'R SLAT (4)
 2 - PCS. 2" X 3" X 71" WOOD EDGE SLAT (5)
 22 - PCS. 5/16" X 1 1/2" SS. BTN. SKT. HD. LAG (8)
 22 - PCS. 5/16" SS. FLAT WASHER (9)
 ATTACH SLATS (4 & 5) TO STEP 2 ASSEMBLY USING
 HARDWARE (8 & 9). TIGHTEN TO SNUG FIT.

STEP 4:

USE 1 - PC. CENTER STRAP (2)
 11 - PCS. 5/16" X 1 1/2" SS. BTN. SKT. HD. LAG (8)
 11 - PCS. 5/16" SS. FLAT WASHER (9)
 ATTACH CENTER STRAP (2) TO STEP 3 ASSEMBLY USING
 HARDWARE (8 & 9). TIGHTEN TO SNUG FIT.

STEP 5:

UPON COMPLETION OF BENCH ASSEMBLY SQUARE ALL COMPONENTS
 THEN TIGHTEN ALL HARDWARE.

STEP 6:

MOUNT AND ANCHOR AS SPECIFIED.

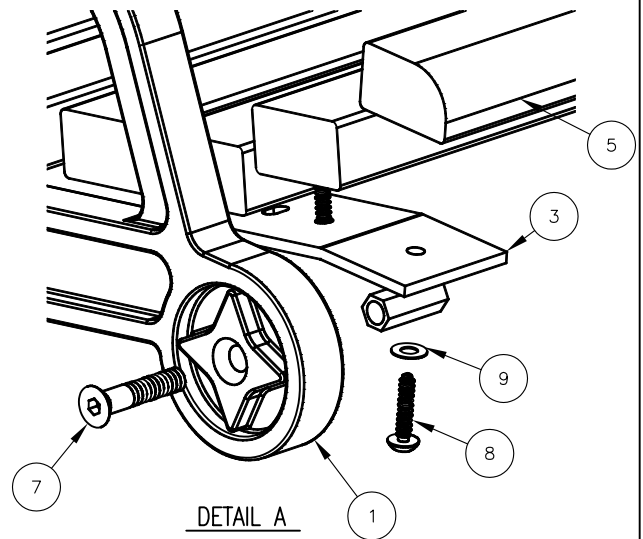

ITEM	QTY	PART NO	DESCRIPTION
1	2	0-140-00-01	CAST IRON BENCH SUPPORT
2	1	0-57-00-03	CENTER CONTOUR STRAP
3	2	0-57-00-05	END CONTOUR STRAP
4	9	0-57-60-01	2" X 3" X 71" WOOD INT'R SLAT
5	2	0-57-60-02	2" X 3" X 71" WOOD EDGE SLATS
6	1	0-57-60-04	71 3/4" PIPE BRACE
7	6	1-12-065	1/2" X 2 1/2" FLT SKT HD CAP SCR
8	33	1-13-023	5/16" X 1 1/2" SS BTN SKT HD LAG
9	33	1-22-017	5/16" SS FLAT WASHER

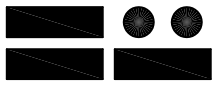
 DuMor, inc. P.O. Box 142 Mifflintown, PA 17059-0142	SCALE :	NONE		
	DATE DRAWN :	7/10/01		
	DRAWN BY :	AWH		
	DATE REV. :	12/15/08		
	REV. BY :	ESS		
	TITLE :	BENCH ASSEMBLY PATENT D467-101		
	REV. B	DRAWING NUMBER	142 SERIES	SHEET 2 OF 2