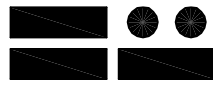

NOTES

- 1.) ALL STL. MEMBERS COATED W/ ZINC RICH EPOXY THEN FINISHED W/ POLYESTER POWDER COATING.
- 2.) 1/2" X 3 3/4" EXPANSION ANCHOR BOLTS PROVIDED.

SLAT OPTIONS

- "CEDAR" RECYCLED PLASTIC
- "GREY" RECYCLED PLASTIC
- "REDWOOD" RECYCLED PLASTIC
- "GREEN" RECYCLED PLASTIC
- OTHER _____

 DuMor, inc. P.O. Box 142 Mifflintown, PA 17059-0142	SCALE :	NONE	TITLE :		BENCH
	DATE DRAWN :	11/12/02	REV.	DRAWING NUMBER	154 SERIES PL
	DRAWN BY :	AWH	A		
	DATE REV. :				
REV. BY :				SHEET	1 OF 2

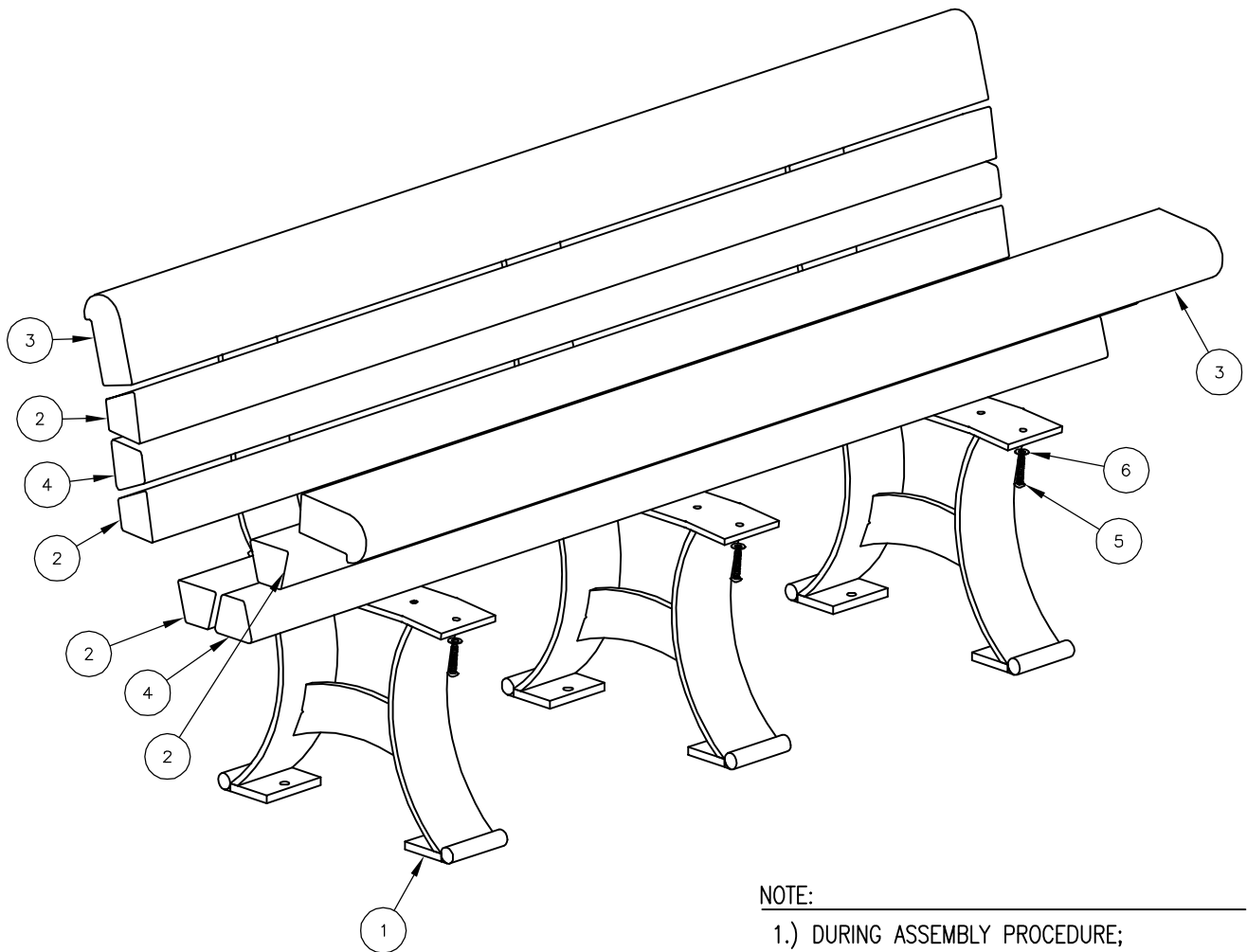

STEP 1:

- USE 3 - PCS. SUPPORT FOR SURFACE MOUNT (1)
- 4 - PCS. 71" PLASTIC TRAP SLAT (2)
- 2 - PCS. 71" PLASTIC EDGE SLAT (3)
- 2 - PCS. 71" PLASTIC TRAP SLAT (4)
- 24 - PCS. 3/8" X 2" S.STL. BTN. SKT. HD. LAG SCREW (5)
- 24 - PCS. 3/8" S.STL. FLAT WASHER (6)

ATTACH 71" PLASTIC EDGE SLAT (3) TO SUPPORT FOR SURFACE MOUNT (1) USING HARDWARE (5 & 6). ATTACH 71" PLASTIC TRAP SLATS (2 & 4), WITH PILOT HOLES IN TRAP SLAT FACING SUPPORT, TO SUPPORT FOR SURFACE MOUNT (1) USING HARDWARE (5 & 6). TIGHTEN TO SNUG FIT.

STEP 2:

UPON COMPLETION OF BENCH ASSEMBLY SQUARE ALL COMPONENTS THEN TIGHTEN ALL HARDWARE.

STEP 3:

MOUNT AND ANCHOR AS SPECIFIED.

NOTE:

- 1.) DURING ASSEMBLY PROCEDURE;
DO NOT COMPLETELY TIGHTEN HARDWARE
- 2.) THE ACTUAL PARTS WILL NOT BE NUMBERED;
NUMBERS ONLY APPLY TO DRAWING.

ITEM	QTY	PART NO	DESCRIPTION
1	3	0-154-00-01/S-2	SUPPORT FOR SURFACE MOUNT
2	4	0-154-60PL-03	71" PLASTIC TRAP SLAT
3	2	0-88-60PL-03	71" PLASTIC EDGE SLAT
4	2	0-88-60PL-04	71" PLASTIC TRAP SLAT
5	24	1-13-016	3/8" X 2" SS BTN SKT HD LAG SCR
6	24	1-22-024	3/8" SS FLAT WASHER

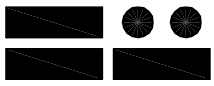
 DuMor, inc. P.O. Box 142 Mifflintown, PA 17059-0142	SCALE :	NONE	TITLE : <h2 style="margin: 0;">BENCH ASSEMBLY</h2>		
	DATE DRAWN :	11/12/02			
	DRAWN BY :	AWH	REV.	DRAWING NUMBER <h3 style="margin: 0;">154 SERIES PL</h3>	SHEET 2 OF 2
	DATE REV. :		A		
	REV. BY :				