

LENGTH OPTIONS

- 6' BENCH
- 8' BENCH

NOTES

- 1.) ALL STL. MEMBERS COATED W/ ZINC RICH EPOXY THEN FINISHED W/ POLYESTER POWDER COATING.
- 2.) ALL WOOD MEMBERS TREATED W/ CLEAR PRESERVATIVE.
- 3.) 1/2" X 3 3/4" EXPANSION ANCHOR BOLTS PROVIDED.

WOOD OPTIONS

- CLEAR ALL HEART REDWOOD S4S EE
- 'C' & BTR. DOUGLAS FIR KD S4S EE
- CLEAR IPE S4S EE
- OTHER \_\_\_\_\_



**DuMor, inc.**

P.O. Box 142 Mifflintown, PA 17059-0142

SCALE : NONE

DATE DRAWN : 9/24/04

DRAWN BY : AWH

DATE REV. : 6/7/09

REV. BY : AWH

TITLE :

BENCH

REV.  
C

DRAWING  
NUMBER

165 SERIES

SHEET  
1 OF 2

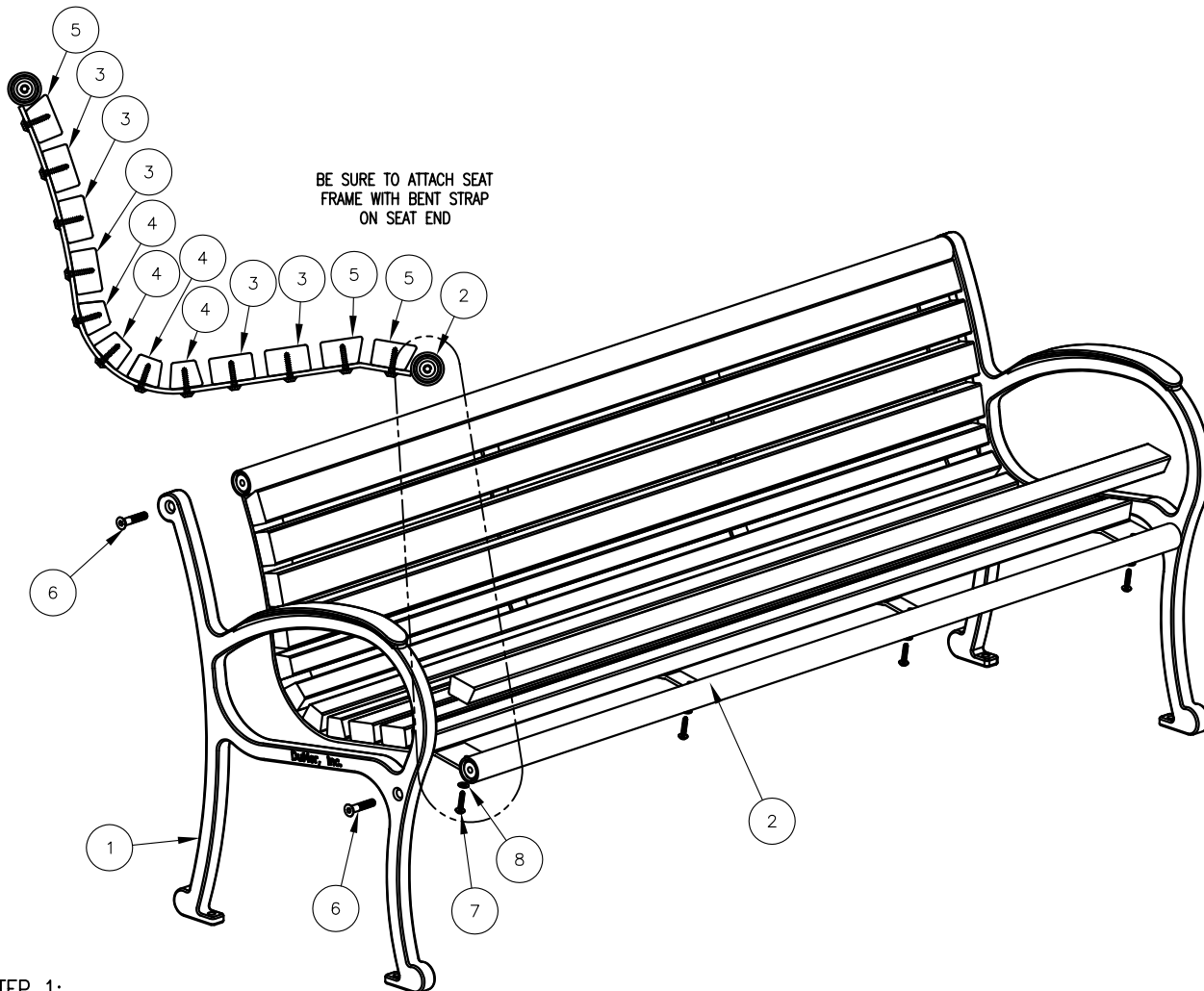

**STEP 1:**

USE 2 - PCS. CAST IRON BENCH SUPPORT W/ BACK ( 1 )  
 1 - PC. 6' SEAT FRAME ( 2 )  
 4 - PCS. 1/2" X 2 1/2" FLT. SKT. HD. CAP SCR. ( 6 )  
 ATTACH CAST IRON SUPPORT W/ BACK ( 1 ) TO 6' SEAT FRAME ( 2 ) USING HARDWARE ( 6 ). TIGHTEN TO SNUG FIT.

**NOTE:**

- 1.) DURING ASSEMBLY PROCEDURE;  
DO NOT COMPLETELY TIGHTEN HARDWARE.
- 2.) THE ACTUAL PARTS WILL NOT BE NUMBERED:  
NUMBERS ONLY APPLY TO DRAWING.

**STEP 2:**

USE 5 - PCS. 2" X 3" X 71" WOOD INT'R SLAT ( 3 )  
 4 - PCS. 71" WOOD TRAP SLAT ( 4 )  
 3 - PCS. 71" WOOD PROFILE SLAT ( 5 )  
 48 - PCS. 5/16" X 1 1/2" SS. BTN. SKT. HD. LAG ( 7 )  
 48 - PCS. 5/16" SS. FLAT WASHER ( 8 )  
 ATTACH SLATS ( 3, 4 & 5 ) TO STEP 1 ASSEMBLY USING HARDWARE ( 7 & 8 ). TIGHTEN TO SNUG FIT.

**STEP 3:**

UPON COMPLETION OF BENCH ASSEMBLY SQUARE ALL COMPONENTS THEN TIGHTEN ALL HARDWARE.

**STEP 4:**

MOUNT AND ANCHOR AS SPECIFIED.

ITEM	QTY	PART NO	DESCRIPTION
1	2	0-160-00-01	CAST IRON BENCH SUPPORT FOR BACKREST
2	1	0-165-60-01	6' SEAT FRAME
3	5	0-165-60-02	2" X 3" X 71" WOOD INT'R SLAT
4	4	0-165-60-03	71" WOOD TRAP SLAT
5	3	0-165-60-04	71" WOOD PROFILE SLAT
6	4	1-12-065	1/2" X 2 1/2" FLT SKT HD CAP SCR
7	48	1-13-023	5/16" X 1 1/2" SS BTN SKT HD LAG
8	48	1-22-017	5/16" SS FLAT WASHER

**DuMor, inc.**  
 P.O. Box 142 Mifflintown, PA 17059-0142

SCALE : NONE  
 DATE DRAWN : 9/24/04  
 DRAWN BY : AWH  
 DATE REV. : 6/4/09  
 REV. BY : AWH

TITLE : BENCH ASSEMBLY

REV. C	DRAWING NUMBER 165 SERIES	SHEET 2 OF 2
--------	---------------------------	--------------