

S-1 EMBEDMENT

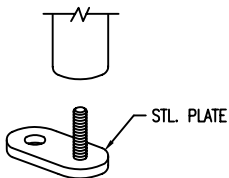

S-2 SURFACE

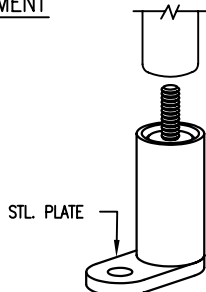

S-4 SUB FLOOR

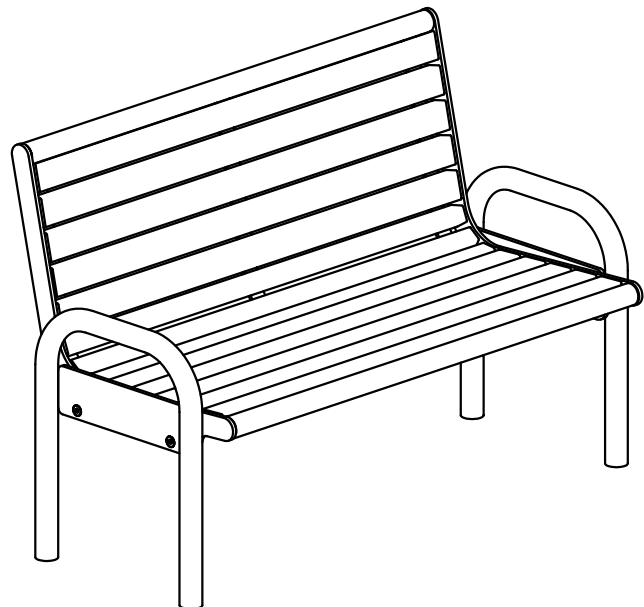

SLAT OPTIONS

- "CEDAR" RECYCLED PLASTIC
- "GREY" RECYCLED PLASTIC
- "GREEN" RECYCLED PLASTIC
- "REDWOOD" RECYCLED PLASTIC
- "WALNUT" RECYCLED PLASTIC
- OTHER _____

NOTES

- 1.) ALL STL. MEMBERS COATED W/ ZINC RICH EPOXY THEN FINISHED W/ POLYESTER POWDER COATING.
- 2.) 1/2" X 3 3/4" EXPANSION ANCHOR BOLTS PROVIDED.



DuMor, inc.

P.O. Box 142 Mifflintown, PA 17059-0142

SCALE : NONE
 DATE DRAWN : 9/25/08
 DRAWN BY : AWH
 DATE REV. : 12/2/09
 REV. BY : AWH

TITLE : BENCH

REV. B

DRAWING NUMBER

177-40PL

SHEET 1 OF 2

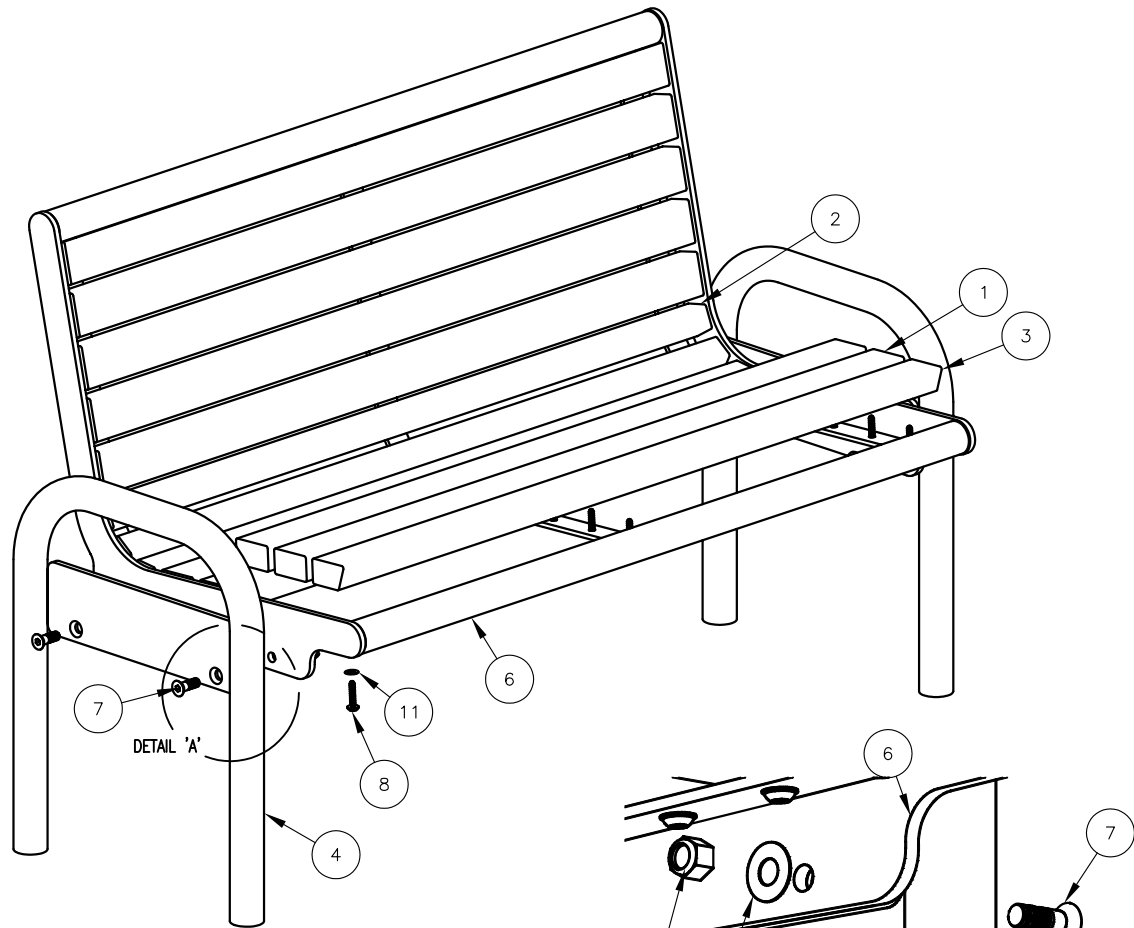

STEP 1:

- USE 2 - PCS. STL. END SUPPORT (4)
 - 1 - PC. 4' STL. SEAT FRAME (5)
 - 4 - PCS. 1/2" X 1 1/2" FLT. SKT. HD. CAP SCR. (6)
 - 4 - PCS. 1/2" SS NYLON LOCKNUT (8)
 - 4 - PCS. 1/2" SS. FLAT WASHER (9)
- ATTACH STL. END SUPPORT (4) TO 4' SEAT FRAME (5) USING HARDWARE (6, 8 & 9). TIGHTEN TO SNUG FIT.

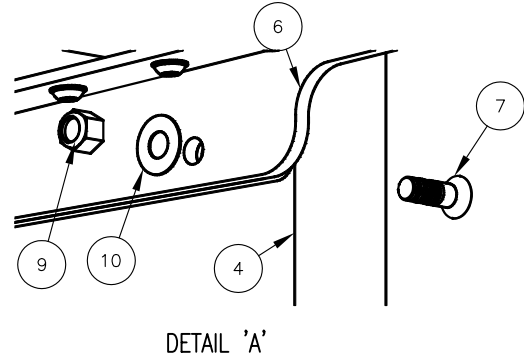

DETAIL 'A'

STEP 2:

- USE 8 - PCS. 2" X 3" X 47" PLASTIC INT'R SLAT (1)
 - 3 - PCS. 47" PLASTIC TRAP SLAT (2)
 - 2 - PCS. 47" PLASTIC PROFILE SLAT (3)
 - 39 - PCS. 5/16" X 1 1/2" SS. BTN. SKT. HD. LAG (7)
 - 39 - PCS. 5/16" SS. FLAT WASHER (10)
- ATTACH SLATS (1, 2 & 3) TO STEP 1 ASSEMBLY USING HARDWARE (7 & 10). TIGHTEN TO SNUG FIT.

NOTE:

- 1.) DURING ASSEMBLY PROCEDURE; DO NOT COMPLETELY TIGHTEN HARDWARE.
- 2.) THE ACTUAL PARTS WILL NOT BE NUMBERED; NUMBERS ONLY APPLY TO DRAWING.

STEP 3:

UPON COMPLETION OF BENCH ASSEMBLY SQUARE ALL COMPONENTS THEN TIGHTEN ALL HARDWARE.

STEP 4:

MOUNT AND ANCHOR AS SPECIFIED.

ITEM	QTY	PART NO	DESCRIPTION
1	8	0-143-40PL-01	2" X 3" X 47" INTERIOR PLASTIC SLAT
2	3	0-165-40PL-03	47" TRAP SLAT, PLASTIC
3	2	0-165-40PL-04	47" PROFILE SLAT, PLASTIC
4	2	0-177-00-01	STL END SUPPORT
6	1	0-177-40-02	4' STL SEAT FRAME
7	4	1-12-074	1/2" X 1 1/2" SS FLT SKT HD CAP
8	39	1-13-023	5/16" X 1 1/2" SS BTN SKT HD LAG
9	4	1-20-015	1/2" SS NYLON LOCKNUT
10	4	1-22-015	1/2" SS FLAT WASHER
11	39	1-22-017	5/16" SS FLAT WASHER

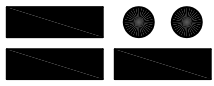
 DuMor, inc. P.O. Box 142 Mifflintown, PA 17059-0142	SCALE :	NONE	TITLE :		BENCH ASSEMBLY
	DATE DRAWN :	9/28/08	REV.	DRAWING NUMBER 177-40PL	SHEET 2 OF 2
	DRAWN BY :	AWH	B		
	DATE REV. :	12/2/09			
REV. BY :	AWH				