

LENGTH OPTIONS

- 6' BENCH
- 8' BENCH

SLAT OPTIONS

- "CEDAR" RECYCLED PLASTIC
- "GREY" RECYCLED PLASTIC
- "REDWOOD" RECYCLED PLASTIC
- "GREEN" RECYCLED PLASTIC
- OTHER _____

NOTES

- 1.) ALL STL. MEMBERS COATED W/ ZINC RICH EPOXY THEN FINISHED W/ POLYESTER POWDER COATING.
- 2.) 1/2" X 3 3/4" EXPANSION ANCHOR BOLTS PROVIDED.



SCALE :	NONE
DATE DRAWN :	9/30/08
DRAWN BY :	AWH
DATE REV. :	
REV. BY :	

TITLE :		BENCH	
REV.	DRAWING NUMBER	178 SERIES PL	SHEET 1 OF 2
A			

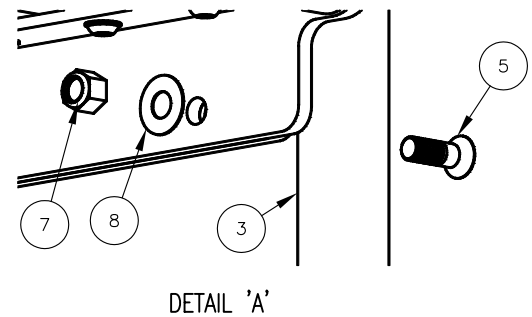
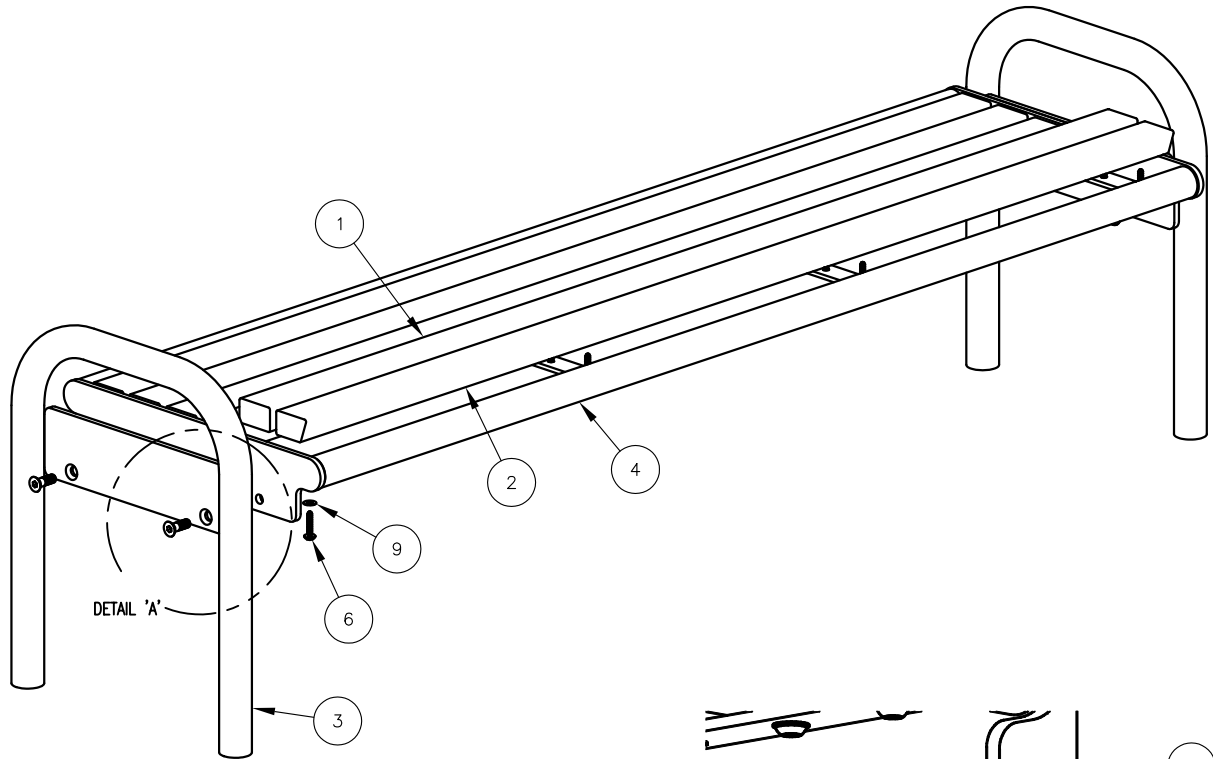

STEP 1:

- USE 2 - PCS. STL. END SUPPORT (3)
 - 1 - PC. 6' STL. SEAT FRAME (4)
 - 4 - PCS. 1/2" X 1 1/2" FLT. SKT. HD. CAP SCR. (5)
 - 4 - PCS. 1/2" SS NYLON LOCKNUT (7)
 - 4 - PCS. 1/2" SS. FLAT WASHER (8)
- ATTACH STL. END SUPPORT (3) TO 6' SEAT FRAME (4) USING HARDWARE (5, 7 & 8). TIGHTEN TO SNUG FIT.

STEP 2:

- USE 4 - PCS. 2" X 3" X 71" PLASTIC INT'R SLAT (1)
 - 2 - PCS. 71" PLASTIC PROFILED SLAT (2)
 - 24 - PCS. 5/16" X 1 1/2" SS. BTN. SKT. HD. LAG (6)
 - 24 - PCS. 5/16" SS. FLAT WASHER (9)
- ATTACH SLATS (1 & 2) TO STEP 1 ASSEMBLY USING HARDWARE (6 & 9). TIGHTEN TO SNUG FIT.

STEP 3:

UPON COMPLETION OF BENCH ASSEMBLY SQUARE ALL COMPONENTS THEN TIGHTEN ALL HARDWARE.

STEP 4:

MOUNT AND ANCHOR AS SPECIFIED.

NOTE:

- 1.) DURING ASSEMBLY PROCEDURE; DO NOT COMPLETELY TIGHTEN HARDWARE.
- 2.) THE ACTUAL PARTS WILL NOT BE NUMBERED: NUMBERS ONLY APPLY TO DRAWING.

ITEM	QTY	PART NO	DESCRIPTION
1	4	0-143-60PL-01	2" X 3" X 71" PLASTIC INT'R SLAT
2	2	0-165-60PL-04	71" PLASTIC PROFILE SLAT
3	2	0-177-00-01	STL END SUPPORT
4	1	0-178-60-02	6' STL SEAT FRAME
5	4	1-12-074	1/2" X 1 1/2" SS FLT SKT HD CAP
6	24	1-13-023	5/16" X 1 1/2" SS BTN SKT HD LAG
7	4	1-20-015	1/2" SS NYLON LOCKNUT
8	4	1-22-015	1/2" SS FLAT WASHER
9	24	1-22-017	5/16" SS FLAT WASHER

DuMor, inc.
P.O. Box 142 Mifflintown, PA 17059-0142

SCALE : NONE
DATE DRAWN : 9/30/08
DRAWN BY : AWH
DATE REV. :
REV. BY :

TITLE : BENCH ASSEMBLY

REV. A

DRAWING NUMBER 178 SERIES PL

SHEET 2 OF 2