

LENGTH OPTIONS

- 6' BENCH
- 8' BENCH

NOTES

- 1.) ALL STL. MEMBERS COATED W/ ZINC RICH EPOXY THEN FINISHED W/ POLYESTER POWDER COATING.
- 2.) ALL WOOD MEMBERS TREATED W/ CLEAR PRESERVATIVE.
- 3.)  $1 \frac{1}{2}$ " X  $3 \frac{3}{4}$ " EXPANSION ANCHOR BOLTS PROVIDED.

WOOD OPTIONS

- CLEAR ALL HEART REDWOOD S4S EE
- 'C' & BTR. DOUGLAS FIR KD S4S EE
- CLEAR IPE S4S EE
- OTHER \_\_\_\_\_

  
**DuMor, inc.**  
 P.O. Box 142 Mifflintown, PA 17059-0142

SCALE : NONE  
 DATE DRAWN : 10/16/09  
 DRAWN BY : AWH  
 DATE REV. : 2/5/10  
 REV. BY : AWH

TITLE : BENCH

REV. B

DRAWING NUMBER 185 SERIES

SHEET 1 OF 2

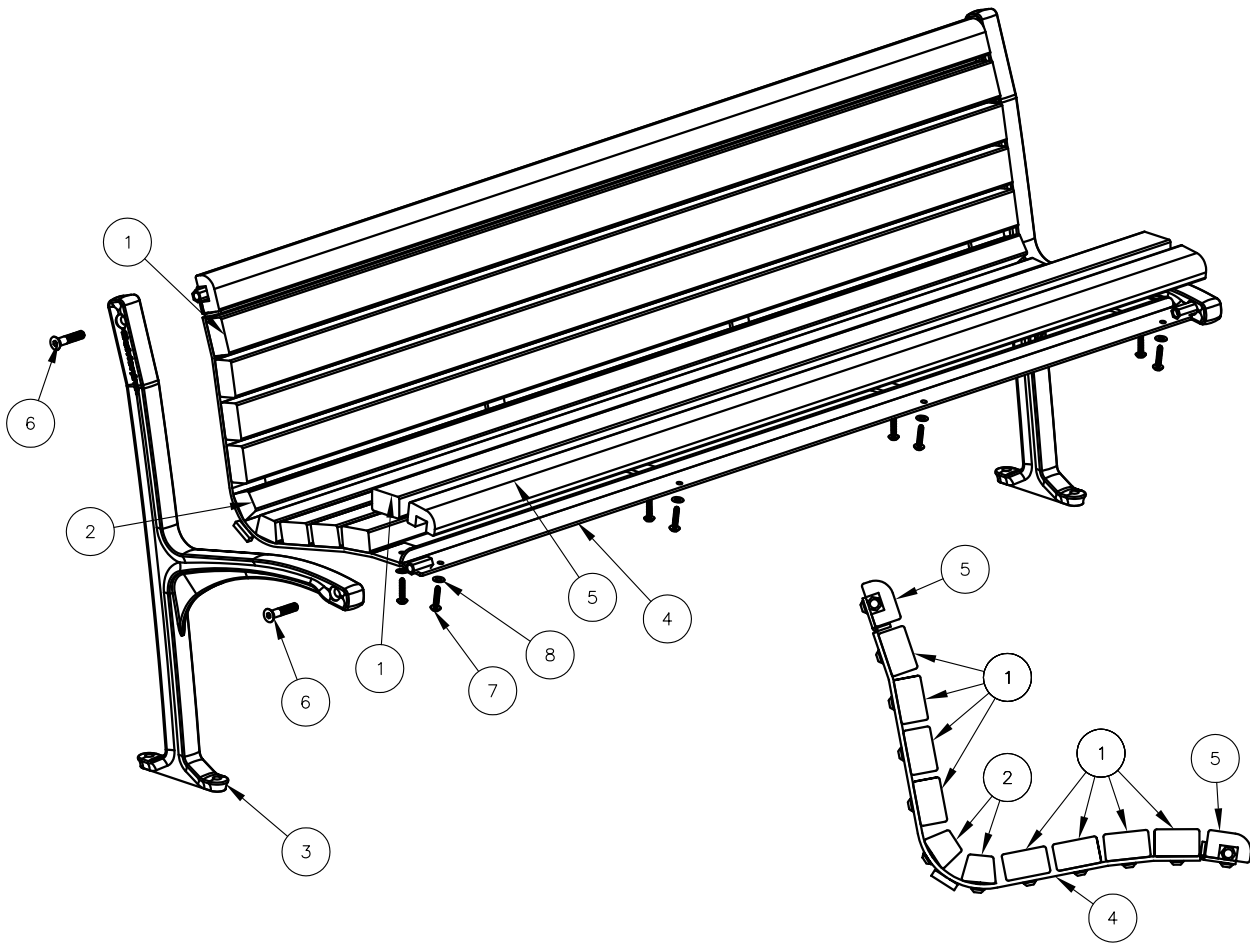

**STEP 1:**

- USE 1 - PCS. 6' SEAT FRAME ( 4 )
  - 8 - PCS. 2" X 3" X 71" SLAT, WOOD ( 1 )
  - 2 - PCS. 71" TRAP SLAT, WOOD ( 2 )
  - 2 - PCS. 71" EDGE SLAT, WOOD ( 5 )
  - 48 - PCS. 5/16" X 1 1/2" SS. BTN. SKT. HD. LAG ( 7 )
  - 48 - PCS. 5/16" SS. FLAT WASHER ( 8 )
- ATTACH WOOD SLATS ( 1, 2 & 5 ) TO 6' SEAT FRAME ( 4 ) USING HARDWARE ( 7 & 8 ). TIGHTEN TO SNUG FIT.

**NOTE:**

- 1.) DURING ASSEMBLY PROCEDURE; DO NOT COMPLETELY TIGHTEN HARDWARE.
- 2.) THE ACTUAL PARTS WILL NOT BE NUMBERED: NUMBERS ONLY APPLY TO DRAWING.

**STEP 2:**

- USE 2 - PCS. D.I. BENCH SUPPORT ( 3 )
  - 4 - PCS. 1/2" X 2 1/2" FLT. SKT. HD. CAP SCR. ( 6 )
- ATTACH D.I. BENCH SUPT ( 3 ) TO STEP 1 ASSEMBLY USING HARDWARE ( 6 ). TIGHTEN TO SNUG FIT.

**STEP 3:**

UPON COMPLETION OF BENCH ASSEMBLY SQUARE ALL COMPONENTS THEN TIGHTEN ALL HARDWARE.

**STEP 4:**

MOUNT AND ANCHOR AS SPECIFIED.

ITEM	QTY	PART NO	DESCRIPTION
1	8	0-165-60-02	2" X 3" X 71" WOOD INT'R SLAT
2	2	0-165-60-03	71" WOOD TRAP SLAT
3	2	0-185-00-01	DUCTILE IRON END SUPPORT
4	1	0-185-60-02	6' STL SEAT FRAME
5	2	0-185-60-05	71" EDGE SLAT, WOOD
6	4	1-12-065	1/2" X 2 1/2" FLT SKT HD CAP SCR
7	48	1-13-023	5/16" X 1 1/2" SS BTN SKT HD LAG
8	48	1-22-017	5/16" SS FLAT WASHER



**DuMor, inc.**

P.O. Box 142 Mifflintown, PA 17059-0142

SCALE : NONE

DATE DRAWN : 10/16/09

DRAWN BY : AWH

DATE REV. : 2/5/10

REV. BY : AWH

TITLE :

BENCH ASSEMBLY

REV.

DRAWING NUMBER

B

185 SERIES

SHEET  
2 OF 2