

LENGTH OPTIONS

- 6' BENCH
- 8' BENCH

NOTES

- 1.) ALL STL. MEMBERS COATED W/ ZINC RICH EPOXY THEN FINISHED W/ POLYESTER POWDER COATING.
- 2.) ALL WOOD MEMBERS TREATED W/ CLEAR PRESERVATIVE.
- 3.) 1/2" X 3 3/4" EXPANSION ANCHOR BOLTS PROVIDED.

WOOD OPTIONS

- CLEAR ALL HEART REDWOOD S4S EE
- 'C' & BTR. DOUGLAS FIR KD S4S EE
- CLEAR IPE S4S EE
- OTHER \_\_\_\_\_

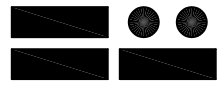
 <b>DuMor, inc.</b> P.O. Box 142 Mifflintown, PA 17059-0142	SCALE :	NONE	TITLE :		BENCH	
	DATE DRAWN :	10/16/09	REV.	DRAWING NUMBER	186 SERIES	SHEET 1 OF 2
	DRAWN BY :	AWH	A			
	DATE REV. :					
	REV. BY :					

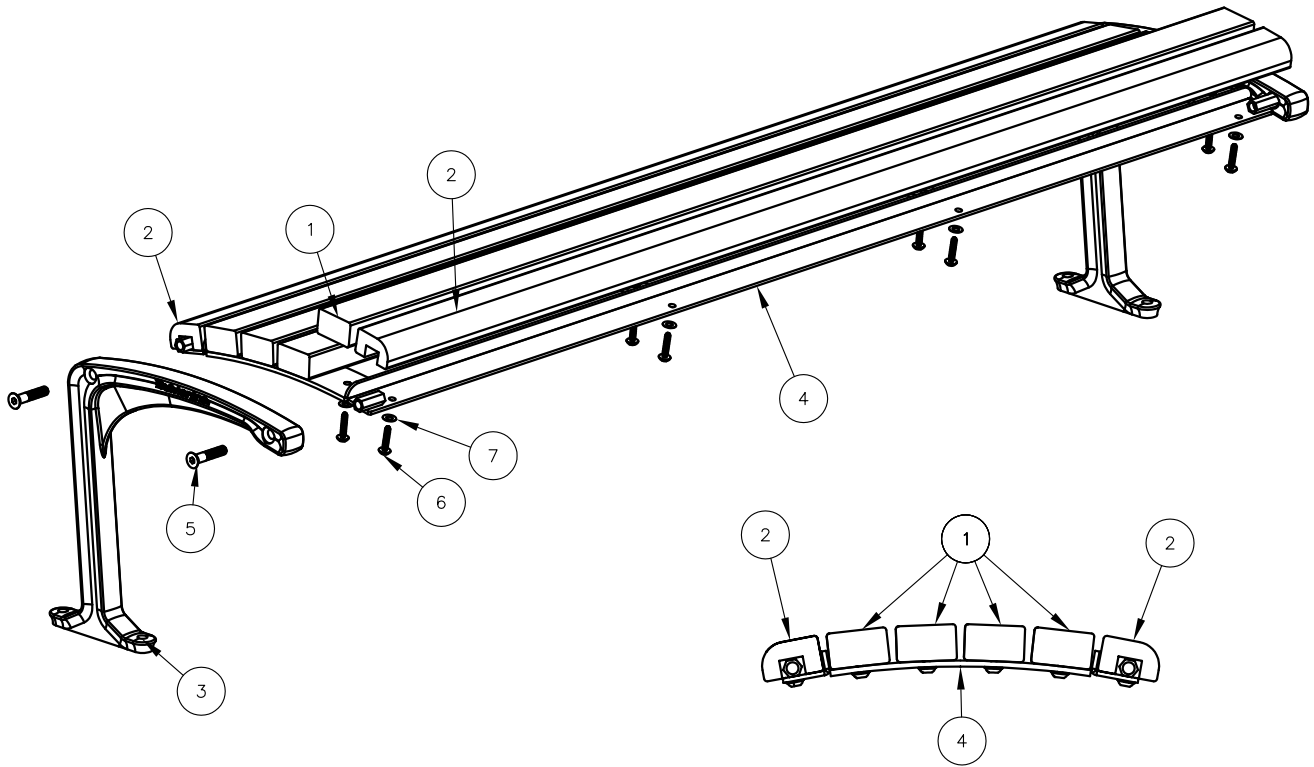

**STEP 1:**

- USE 4 - PCS. 2" X 3" X 71" SLAT ( 1 )
  - 2 - PCS. 71" EDGE SLAT ( 2 )
  - 1 - PC. 6' SEAT FRAME ( 4 )
  - 24 - PCS. 5/16" X 1 1/2" SS. BTN. SKT. HD. LAG ( 6 )
  - 24 - PCS. 5/16" SS. FLAT WASHER ( 7 )
- ATTACH SLATS ( 1 & 2 ) TO 6' SEAT FRAME ( 4 ) USING HARDWARE ( 6 & 7 ). TIGHTEN TO SNUG FIT.

**NOTE:**

- 1.) DURING ASSEMBLY PROCEDURE;  
DO NOT COMPLETELY TIGHTEN HARDWARE.
- 2.) THE ACTUAL PARTS WILL NOT BE NUMBERED;  
NUMBERS ONLY APPLY TO DRAWING.

**STEP 2:**

- USE 2 - PCS. BKLS BENCH SUPPORT ( 3 )
  - 4 - PCS. 1/2" X 2 1/2" FLT. SKT. HD. CAP SCR. ( 5 )
- ATTACH BKLS BENCH SUPT ( 3 ) TO STEP 1 ASSEMBLY USING HARDWARE ( 5 ). TIGHTEN TO SNUG FIT.

**STEP 3:**

UPON COMPLETION OF BENCH ASSEMBLY SQUARE ALL COMPONENTS THEN TIGHTEN ALL HARDWARE.

**STEP 4:**

MOUNT AND ANCHOR AS SPECIFIED.

ITEM	QTY	PART NO	DESCRIPTION
1	4	0-165-60-02	2" X 3" X 71" WOOD INT'R SLAT
2	2	0-185-60-05	71" EDGE SLAT, WOOD
3	2	0-186-00-01	BKLS BENCH SUPT
4	1	0-186-60-02	6' BKLS BENCH FRAME
5	4	1-12-065	1/2" X 2 1/2" FLT SKT HD CAP SCR
6	24	1-13-023	5/16" X 1 1/2" SS BTN SKT HD LAG
7	24	1-22-017	5/16" SS FLAT WASHER

**DuMor, inc.**  
P.O. Box 142 Mifflintown, PA 17059-0142

SCALE : NONE  
DATE DRAWN : 10/16/09  
DRAWN BY : AWH  
DATE REV. :  
REV. BY :

TITLE : BENCH ASSEMBLY

REV. A	DRAWING NUMBER 186 SERIES	SHEET 2 OF 2
--------	---------------------------	--------------