

NOTES

- 1.) ALL STL. MEMBERS COATED W/ ZINC RICH EPOXY THEN FINISHED W/ POLYESTER POWDER COATING.
- 2.) 1/2" X 3 3/4" EXPANSION ANCHOR BOLTS PROVIDED.

SLAT OPTIONS

- "CEDAR" RECYCLED PLASTIC
- "GREY" RECYCLED PLASTIC
- "GREEN" RECYCLED PLASTIC
- "REDWOOD" RECYCLED PLASTIC
- "WALNUT" RECYCLED PLASTIC
- OTHER _____

DuMor, inc.
 P.O. Box 142 Mifflintown, PA 17059-0142

SCALE : NONE
 DATE DRAWN : 11/15/10
 DRAWN BY : JSB
 DATE REV. :
 REV. BY :

TITLE : BENCH

REV. A	DRAWING NUMBER 186-80PL	SHEET 1 OF 2
--------	-------------------------	--------------

NOTE:

- 1.) DURING ASSEMBLY PROCEDURE;
DO NOT COMPLETELY TIGHTEN HARDWARE.
- 2.) THE ACTUAL PARTS WILL NOT BE NUMBERED;
NUMBERS ONLY APPLY TO DRAWING.

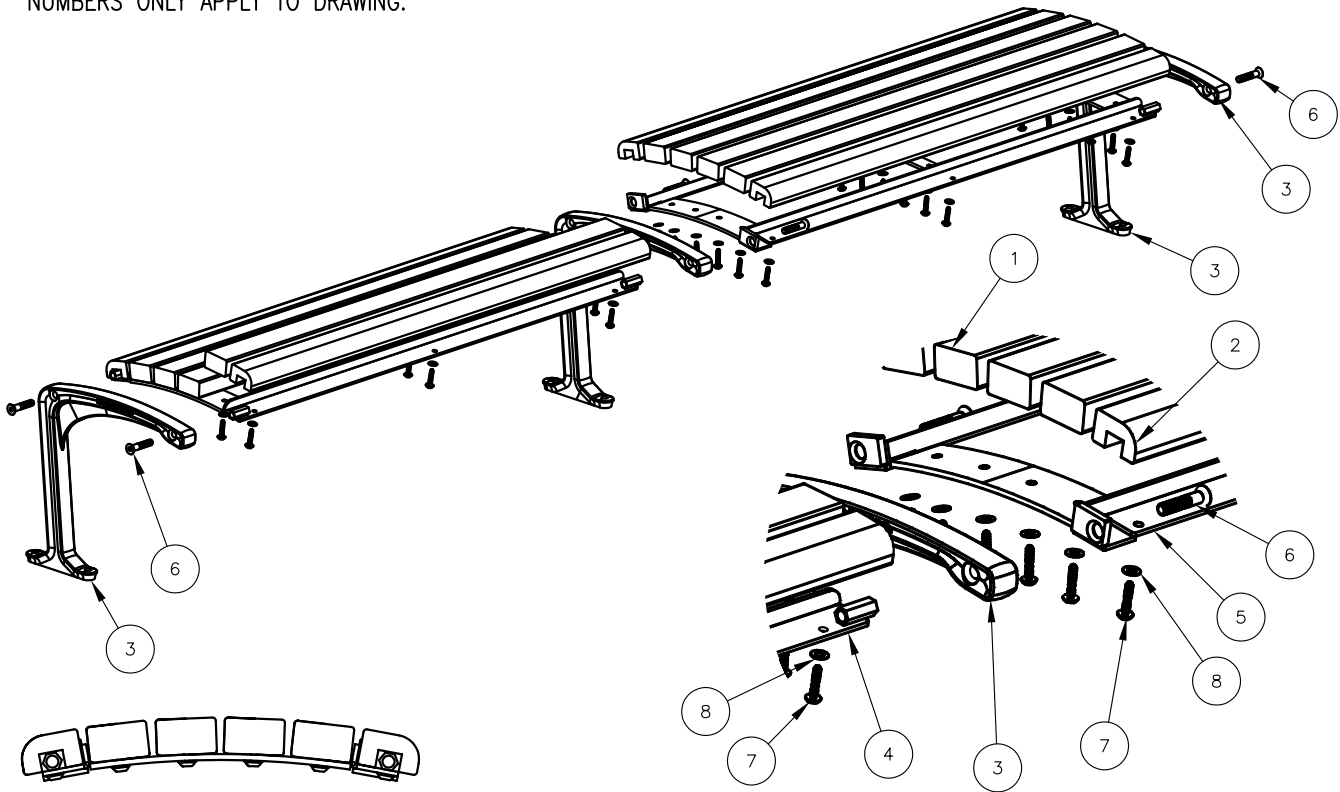

STEP 1:

USE 1 - PC. BKLS BENCH SUPPORT (3)
 1 - PC. 4' BKLS BENCH FRAME (4)
 2 - PCS. 1/2" X 2 1/2" FLT. SKT. HD. CAP SCR. (6)
 ATTACH BKLS BENCH SUPPORT (3) TO 4' BKLS BENCH
 FRAME (4) USING HARDWARE (6). TIGHTEN TO SNUG FIT.

STEP 2:

USE 1 - PC. BKLS BENCH SUPPORT (3)
 1 - PC. 4' BKLS LEFT BENCH FRAME (5)
 2 - PCS. 1/2" X 2 1/2" FLT. SKT. HD. CAP SCR. (6)
 ATTACH BKLS BENCH SUPPORT (3) TO 4' BKLS LEFT BENCH
 FRAME (5) USING HARDWARE (6). TIGHTEN TO SNUG FIT.

STEP 3:

USE 1 - PC. BKLS BENCH SUPPORT (3)
 2 - PCS. 1/2" X 2 1/2" FLT. SKT. HD. CAP SCR. (6)
 ATTACH BKLS BENCH SUPT (3) TO STEP 1 & 2 ASSEMBLY
 USING HARDWARE (6). TIGHTEN TO SNUG FIT.

STEP 4:

USE 8 - PCS. 2" X 3" X 47" PLASTIC SLAT (1)
 4 - PCS. 47" PLASTIC EDGE SLAT (2)
 36 - PCS. 5/16" X 1 1/2" SS. BTN. SKT. HD. LAG (7)
 36 - PCS. 5/16" SS. FLAT WASHER (8)
 ATTACH PLASTIC SLATS (1 & 2) TO STEP 3 ASSEMBLY
 USING HARDWARE (7 & 8). TIGHTEN TO SNUG FIT.

STEP 5:

UPON COMPLETION OF BENCH ASSEMBLY SQUARE ALL
 COMPONENTS THEN TIGHTEN ALL HARDWARE.

STEP 6:

MOUNT AND ANCHOR AS SPECIFIED.

ITEM	QTY	PART NO	DESCRIPTION
1	8	0-143-40PL-01	2" X 3" X 47" INTERIOR PLASTIC SLAT
2	4	0-185-40PL-05	47" EDGE SLAT, PLASTIC
3	3	0-186-00-01	BKLS BENCH SUPT
4	1	0-186-40-02	4' BKLS BENCH FRAME
5	1	0-186-40-06	4' BKLS LEFT BENCH FRAME
6	6	1-12-065	1/2" X 2 1/2" FLT SKT HD CAP SCR
7	36	1-13-023	5/16" X 1 1/2" SS BTN SKT HD LAG
8	36	1-22-017	5/16" SS FLAT WASHER

DuMor, inc.
 P.O. Box 142 Mifflintown, PA 17059-0142

SCALE : NONE
 DATE DRAWN : 11/15/10
 DRAWN BY : JSB
 DATE REV. :
 REV. BY :

TITLE : BENCH ASSEMBLY
 REV. A
 DRAWING NUMBER 186-80PL
 SHEET 2 OF 2