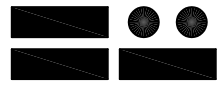

LENGTH OPTIONS

- 6' BENCH
- 8' BENCH

NOTES

- 1.) ALL STL. MEMBERS COATED W/ ZINC RICH COATING THEN POLYESTER POWDER COATED.
- 2.) BENCH IS SHIPPED UNASSEMBLED.
- 3.) 1/2" X 3 3/4" EXPANSION ANCHOR BOLTS PROVIDED.

 DuMor, inc. P.O. Box 142 Mifflintown, PA 17059-0142	SCALE :	NONE	TITLE :		BENCH
	DATE DRAWN :	09/23/10	REV.	DRAWING NUMBER	
	DRAWN BY :	ESS	A	192 SERIES	SHEET
	DATE REV. :				1 OF 2
	REV. BY :				

NOTE:

- 1.) DURING ASSEMBLY PROCEDURE;
DO NOT COMPLETELY TIGHTEN HARDWARE.
- 2.) THE ACTUAL PARTS WILL NOT BE NUMBERED;
NUMBERS ONLY APPLY TO DRAWING.

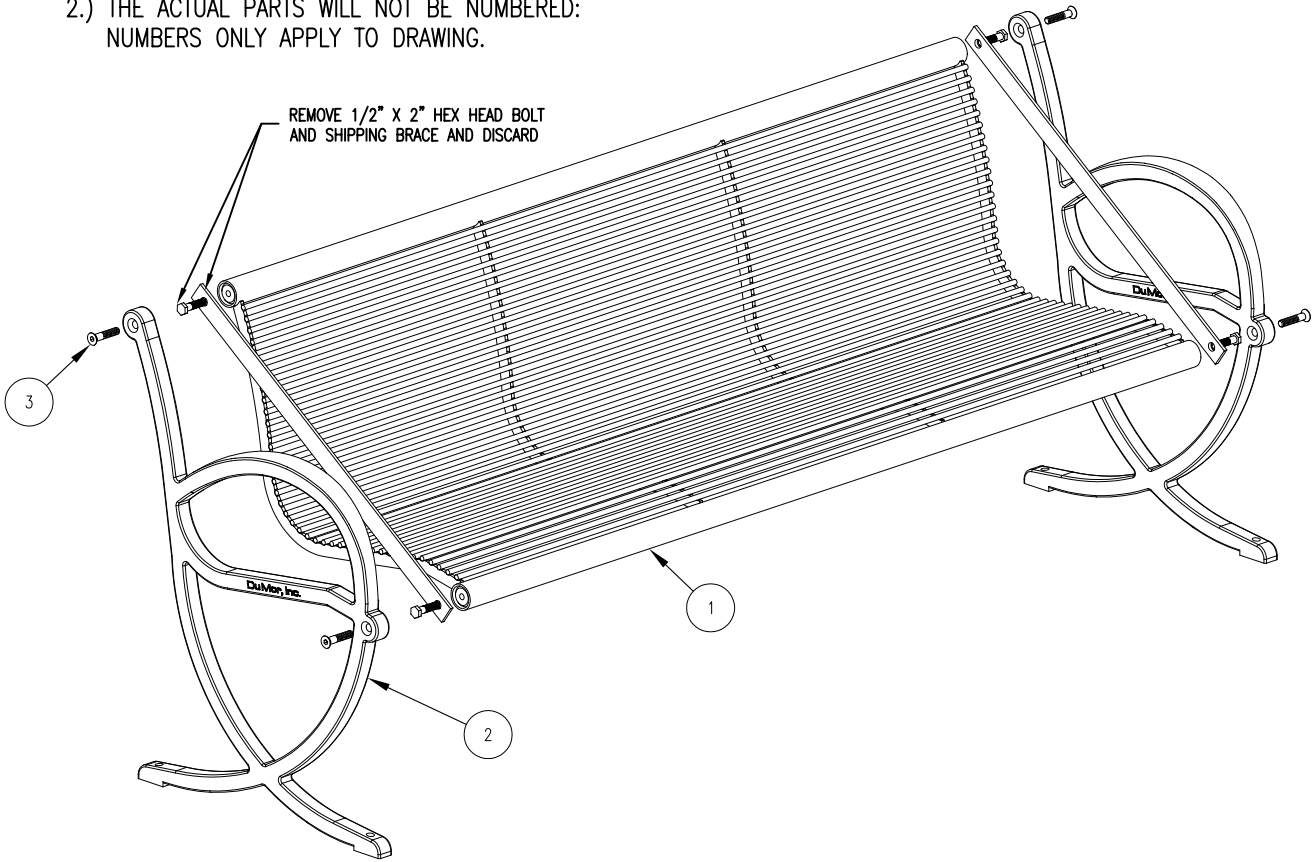

STEP 1:

USE 2 - PCS. CAST IRON BENCH SUPPORT W/ BACK (2)
 1 - PC. 6' ALL STL WELDED SEAT SECTION (1)
 4 - PCS. 1/2" X 2 1/2" FLT. SKT. HD. CAP SCR. (3)
 ATTACH CAST IRON BENCH SUPPORT W/ BACK (2) TO 6' ALL
 STL WELDED SEAT ASSEMBLY (1) USING HARDWARE (3).
 TIGHTEN TO SNUG FIT.

STEP 2:

UPON COMPLETION OF BENCH ASSEMBLY SQUARE ALL
 COMPONENTS THEN TIGHTEN ALL HARDWARE.

STEP 3:

MOUNT AND ANCHOR AS SPECIFIED.

ITEM	QTY	PART NO	DESCRIPTION
1	1	0-168-60-01	6' STL SEAT
2	2	0-190-00-01	CAST IRON BENCH SUPPORT
3	4	1-12-065	1/2" X 2 1/2" FLT SKT HD CAP SCR

DuMor, inc.
 P.O. Box 142 Mifflintown, PA 17059-0142

SCALE : NONE	TITLE : BENCH ASSEMBLY
DATE DRAWN : 09/23/10	REV. : A
DRAWN BY : ESS	DRAWING NUMBER 192 SERIES
DATE REV. :	SHEET 2 OF 2
REV. BY :	