

2" X 3" (NOM.) SLATS
(SEE WOOD OPTIONS)

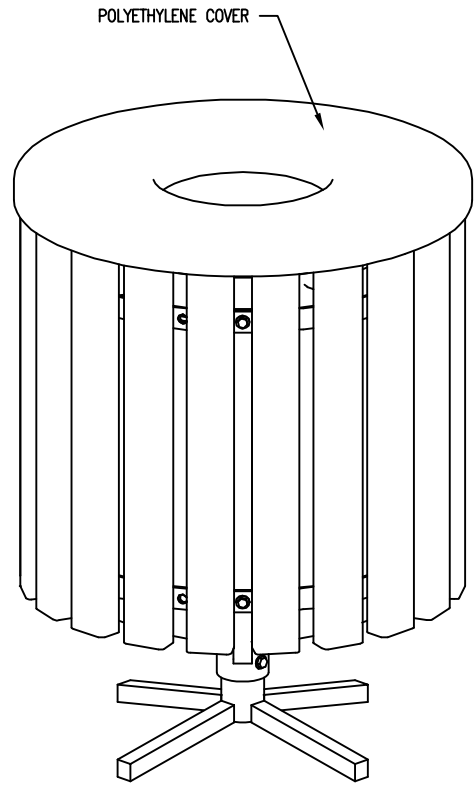
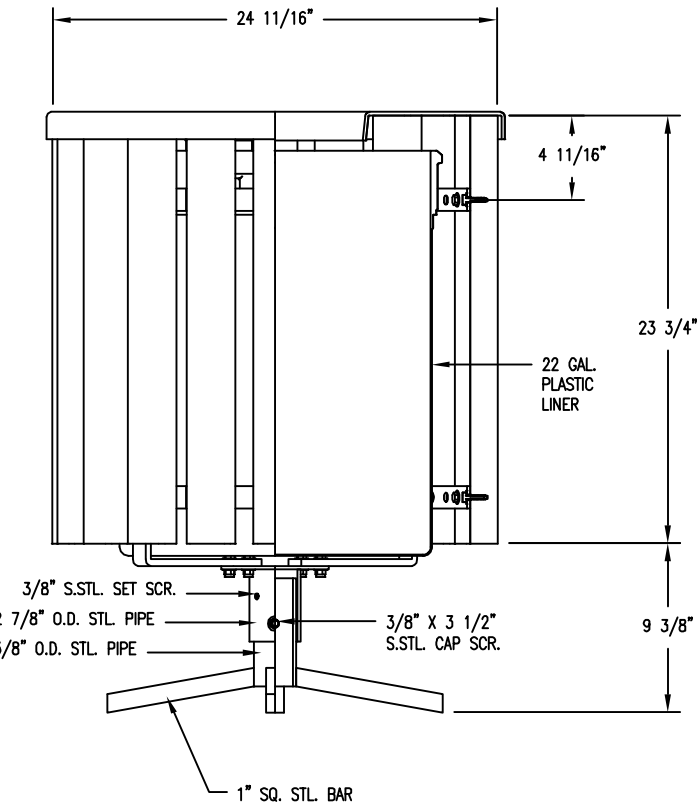
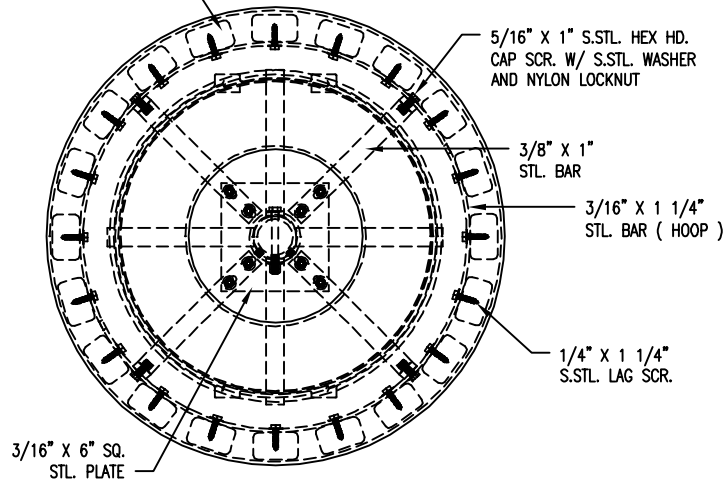

NOTES

- 1.) ALL STL. MEMBERS COATED W/ ZINC RICH EPOXY THEN FINISHED W/ BLACK POLYESTER POWDER COATING.
- 2.) ALL WOOD MEMBERS TREATED W/ CLEAR PRESERVATIVE.

WOOD OPTIONS

- CLEAR ALL HEART REDWOOD S4S EE
- 'C' & BTR. DOUGLAS FIR KD S4S EE
- CLEAR WESTERN RED CEDAR S4S EE
- OTHER _____

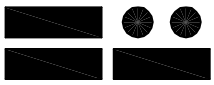
 DuMor, inc. P.O. Box 142 Mifflintown, PA 17059-0142	SCALE :	NONE	TITLE : RECEPTACLE		
	DATE DRAWN :	3/22/94			
	DRAWN BY :	AH	REV. G	DRAWING NUMBER 43-22/46-00	SHEET 1 OF 2
	DATE REV. :	4/6/06			
REV. BY :	JSB				

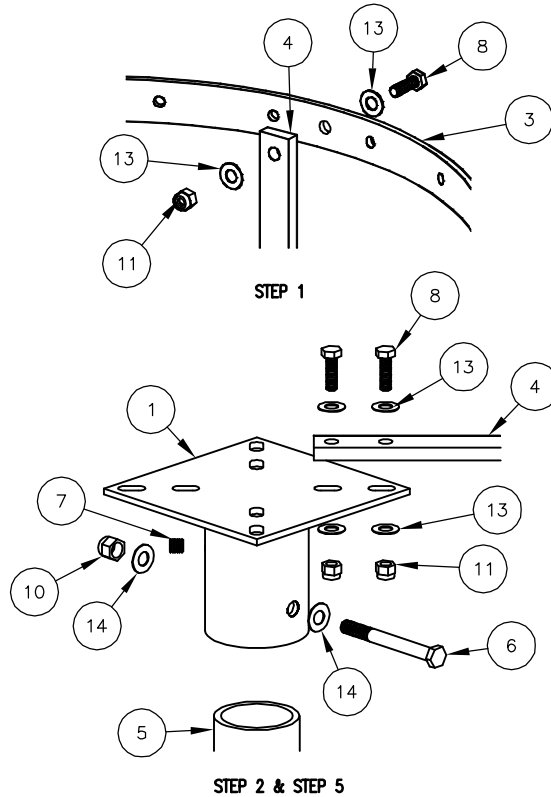
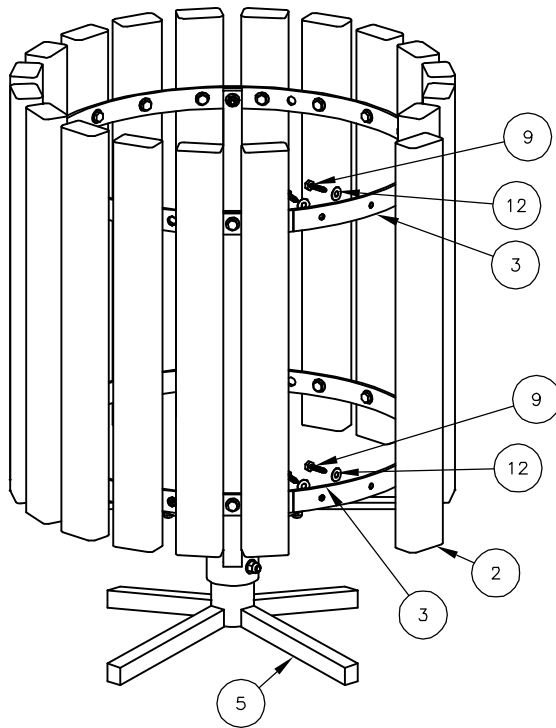

NOTE:

- 1.) DURING ASSEMBLY PROCEDURE:
DO NOT COMPLETELY TIGHTEN HARDWARE.
- 2.) THE ACTUAL PARTS WILL NOT BE NUMBERED:
NUMBERS ONLY APPLY TO DRAWING.
- 3.) SEE SPEC. SHEET 1 FOR OTHER MOUNTING OPTIONS.
- 4.) 2 HOLES IN HOOPS (1/2" DIA.) TO BE LEFT OPEN.

STEP 1:

USE 2 - PCS. HOOP FOR 20 GAL (3)
 4 - PCS. "L" SUPPORT STRAP FOR 20 GAL (4)
 8 - PCS. 5/16" X 1" SS. HEX HD. CAP SCR. (8)
 8 - PCS. 5/16" SS. NYLON LOCK NUT (11)
 16 - PCS. 5/16" SS. FLAT WASHER (13)
 ATTACH "L" SUPPORT STRAP (4) TO INSIDE OF HOOP (3) USING
 HARDWARE (8, 11, & 13). TIGHTEN TO SNUG FIT.
 REPEAT UNTIL ALL "L" SUPPORT STRAPS ARE ATTACHED TO HOOPS.

STEP 2:

USE 1 - PC. CENTER BRACKET (1)
 8 - PCS. 5/16" X 1" SS. HEX HD. CAP SCR. (8)
 8 - PCS. 5/16" SS. NYLON LOCK NUT (11)
 16 - PCS. 5/16" SS. FLAT WASHER (13)
 ATTACH CENTER BRACKET TO STEP 1 ASSEMBLY USING
 HARDWARE (8, 11, & 13). TIGHTEN TO SNUG FIT.

STEP 3:

USE 20 - PCS. 2" X 3" X 23 3/4" WOOD SLAT (2)
 40 - PCS. 1/4" X 1 1/4" SS. HEX HD. LAG SCR. (9)
 40 - PCS. 1/4" SS. FLAT WASHER (12)
 ATTACH 2" X 3" X 23 3/4" WOOD SLATS (2) TO STEP 2
 ASSEMBLY USING HARDWARE (9 & 12). TIGHTEN
 TO SNUG FIT. REPEAT UNTIL ALL SLATS ARE ATTACHED.

STEP 4:

UPON COMPLETION OF BASKET ASSEMBLY SQUARE ALL
 COMPONENTS THEN TIGHTEN ALL HARDWARE.

STEP 5:

USE 1 - PC. SUPPORT FOR SURFACE MOUNT (1)
 1 - PC. 3/8" X 3 1/2" SS. HEX HD. CAP SCR. (6)
 1 - PC. 3/8" SS. NYLON LOCK NUT (10)
 2 - PC. 3/8" SS. FLAT WASHER (14)
 2 - PCS. 3/8" X 3/8" SS. SKT. SET SCR. (7)
 ATTACH SURFACE MOUNT SUPPORT (1) TO STEP 4
 ASSEMBLY USING HARDWARE (6, 10, 14, & 7) AND
 TIGHTEN ALL HARDWARE.

STEP 6:

TO ATTACH COVER, REMOVE ONE 1/4" X 1 1/4" LAG SCREW
 AND FASTEN OPEN END OF CABLE TO BASKET USING
 THE LAG REMOVED.

ITEM	QTY	PART NO	DESCRIPTION
1	1	0-41-00-04	CENTER BRACKET
2	20	0-41-20-01	2" X 3" X 23 3/4" WOOD SLAT
3	2	0-41-20-02	HOOP FOR 20 GAL (21 11/16" DIA)
4	4	0-41-20-05	"L" SUPPORT STRAP FOR 20 GAL
5	1	0-43-00-01	FREE STANDING BASE
6	1	1-12-034	3/8" X 3 1/2" SS HEX HD CAP SCR
7	2	1-12-054	3/8" X 3/8" SS SKT SET SCR
8	16	1-12-061	5/16" X 1" SS HEX HD CAP SCR
9	40	1-13-004	1/4" X 1 1/4" SS HEX HD LAG SCR
10	1	1-20-007	3/8" SS NYLON LOCKNUT
11	16	1-20-016	5/16" SS NYLON LOCKNUT
12	40	1-22-006	1/4" SS FLAT WASHER
13	32	1-22-017	5/16" SS FLAT WASHER
14	2	1-22-024	3/8" SS FLAT WASHER

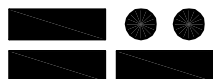

DuMor, inc.

P.O. Box 142 Mifflintown, PA 17059-0142

SCALE : NONE

DATE DRAWN : 12/29/99

DRAWN BY : JSB

DATE REV. : 4/6/06

REV. BY : JSB

TITLE : RECEPTACLE ASSEMBLY

REV.

DRAWING
NUMBER

43-22/46-00

SHEET
2 OF 2