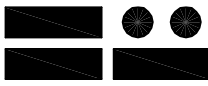

NOTES

- 1.) ALL STL. MEMBERS COATED W/ ZINC RICH EPOXY THEN FINISHED W/ BLACK POLYESTER POWDER COATING.
- 2.) ALL WOOD MEMBERS TREATED W/ CLEAR PRESERVATIVE.

WOOD OPTIONS

- CLEAR ALL HEART REDWOOD S4S EE
- 'C' & BTR. DOUGLAS FIR KD S4S EE
- CLEAR WESTERN RED CEDAR S4S EE
- OTHER _____

 DuMor, inc. P.O. Box 142 Mifflintown, PA 17059-0142	SCALE :	NONE	TITLE :		RECEPTACLE
	DATE DRAWN :	12/29/95	REV.	DRAWING NUMBER	43-32/46-00
	DRAWN BY :	AH	G		
	DATE REV. :	4/6/06			
REV. BY :	JSB			SHEET	1 OF 2

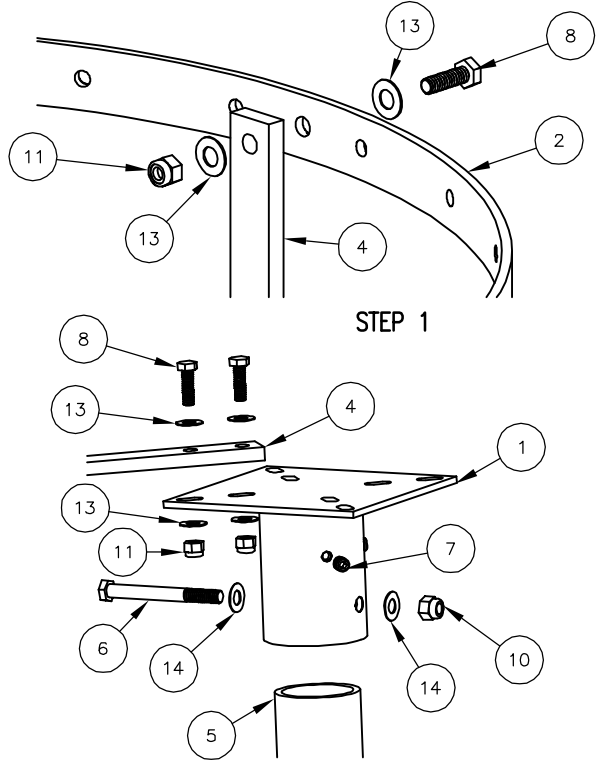
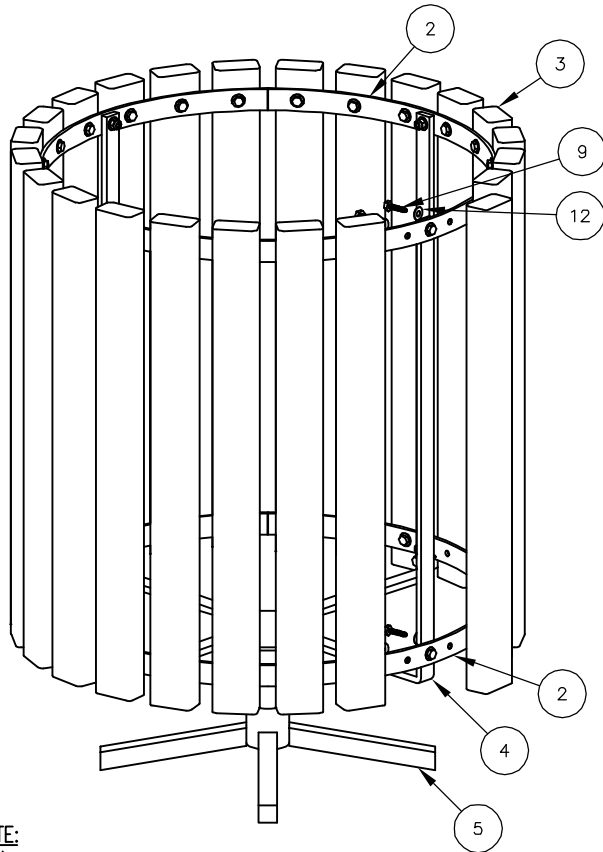

NOTE:

- 1.) DURING ASSEMBLY PROCEDURE:
DO NOT COMPLETELY TIGHTEN HARDWARE.
- 2.) THE ACTUAL PARTS WILL NOT BE NUMBERED:
NUMBERS ONLY APPLY TO DRAWING.

STEP 1:

- USE 2 - PCS. HOOP FOR 30 GAL (2)
 - 4 - PCS. "L" SUPPORT STRAP FOR 30 GAL (4)
 - 8 - PCS. 5/16" X 1" SS. HEX HD. CAP SCR. (8)
 - 8 - PCS. 5/16" SS. NYLON LOCK NUT (11)
 - 16 - PCS. 5/16" SS. FLAT WASHER (13)
- ATTACH "L" SUPPORT STRAP (4) TO INSIDE OF HOOPS (2) USING HARDWARE (8, 11, & 13). TIGHTEN TO SNUG FIT.
REPEAT UNTIL ALL "L" SUPPORT STRAPS ARE ATTACHED TO HOOPS.

STEP 2:

- USE 1 - PC. CENTER BRACKET (1)
 - 8 - PCS. 5/16" X 1" SS. HEX HD. CAP SCR. (8)
 - 8 - PCS. 5/16" SS. NYLON LOCK NUT (11)
 - 16 - PCS. 5/16" SS. FLAT WASHER (13)
- ATTACH CENTER BRACKET (1) TO STEP 1 ASSEMBLY USING HARDWARE (8, 11, & 13). TIGHTEN TO SNUG FIT.

STEP 3:

- USE 24 - PCS. 2" X 3" X 28 1/2" WOOD SLAT (3)
 - 48 - PCS. 1/4" X 1 1/4" SS. HEX HD. LAG SCR. (9)
 - 48 - PCS. 1/4" SS. FLAT WASHER (12)
- ATTACH 2" X 3" X 28 1/2" WOOD SLATS (3) TO STEP 2 ASSEMBLY USING HARDWARE (9 & 12). TIGHTEN TO SNUG FIT. REPEAT UNTIL ALL SLATS ARE ATTACHED.

STEP 4:

UPON COMPLETION OF BASKET ASSEMBLY SQUARE ALL COMPONENTS THEN TIGHTEN ALL HARDWARE.

STEP 5:

- USE 1 - PC. FREE STANDING BASE (5)
 - 1 - PC. 3/8" X 3 1/2" SS. HEX HD. CAP SCR. (6)
 - 1 - PC. 3/8" SS. NYLON LOCKNUT (10)
 - 2 - PC. 3/8" SS. FLAT WASHER (14)
 - 2 - PCS. 3/8" X 3/8" SS. SKT. SET SCR. (7)
- ATTACH FREE STANDING BASE (6) TO STEP 4 ASSEMBLY USING HARDWARE (6, 7, 10, & 14) AND TIGHTEN ALL HARDWARE.

STEP 6:

TO ATTACH COVER, REMOVE ONE 1/4" X 1 1/4" LAG SCREW AND FASTEN OPEN END OF CABLE TO BASKET USING THE LAG REMOVED.

ITEM	QTY	PART NO	DESCRIPTION
1	1	0-41-00-04	CENTER BRACKET
2	2	0-41-30-01	HOOP FOR 30 GAL
3	24	0-41-30-06	2" X 3" X 28 1/2" WOOD SLAT
4	4	0-41-30-07	"L" SUPPORT STRAP FOR 30 GAL
5	1	0-43-00-01	FREE STANDING BASE
6	1	1-12-034	3/8" X 3 1/2" SS HEX HD CAP SCR
7	2	1-12-054	3/8" X 3/8" SS SKT SET SCR
8	16	1-12-061	5/16" X 1" SS HEX HD CAP SCR
9	48	1-13-004	1/4" X 1 1/4" SS HEX HD LAG SCR
10	1	1-20-007	3/8" SS NYLON LOCKNUT
11	16	1-20-016	5/16" SS NYLON LOCKNUT
12	48	1-22-006	1/4" SS FLAT WASHER
13	32	1-22-017	5/16" SS FLAT WASHER
14	2	1-22-024	3/8" SS FLAT WASHER

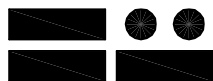

DuMor, inc.

P.O. Box 142 Mifflintown, PA 17059-0142

SCALE : NONE

DATE DRAWN : 12/29/99

DRAWN BY : JSB

DATE REV. : 4/6/06

REV. BY : JSB

TITLE : RECEPTACLE ASSEMBLY

REV.

DRAWING NUMBER

43-32/46-00

SHEET

2 OF 2