

NOTES

1.) STL. MEMBERS COATED W/ ZINC RICH EPOXY THEN FINISHED W/ POLYESTER POWDER COATING.

DuMor, inc.
 P.O. Box 142 Mifflintown, PA 17059-0142

SCALE : NONE
 DATE DRAWN : 11/1/05
 DRAWN BY : AWH
 DATE REV. : 3/30/06
 REV. BY : JSB

TITLE : BOLLARD
 REV. B
 DRAWING NUMBER 450-36-01/S-1X
 SHEET 1 OF 2

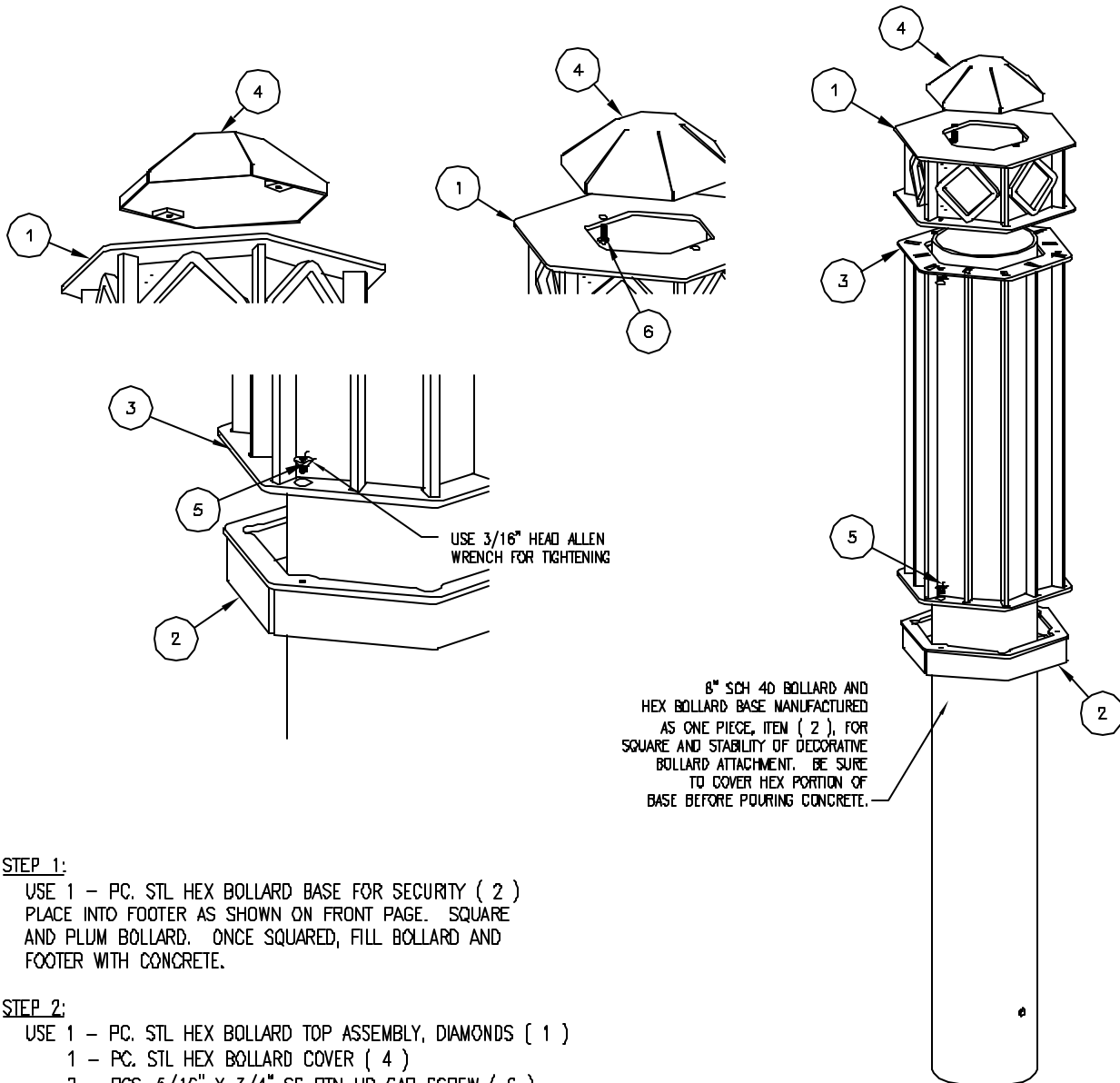

8" SCH 40 BOLLARD AND HEX BOLLARD BASE MANUFACTURED AS ONE PIECE, ITEM (2), FOR SQUARE AND STABILITY OF DECORATIVE BOLLARD ATTACHMENT. BE SURE TO COVER HEX PORTION OF BASE BEFORE POURING CONCRETE.

STEP 1:

USE 1 - PC. STL HEX BOLLARD BASE FOR SECURITY (2)
 PLACE INTO FOOTER AS SHOWN ON FRONT PAGE. SQUARE AND PLUM BOLLARD. ONCE SQUARED, FILL BOLLARD AND FOOTER WITH CONCRETE.

STEP 2:

USE 1 - PC. STL HEX BOLLARD TOP ASSEMBLY, DIAMONDS (1)
 1 - PC. STL HEX BOLLARD COVER (4)
 2 - PCS. 5/16" X 3/4" SS BTN HD CAP SCREW (6)
 ATTACH STL HEX BOLLARD COVER (4) TO HEX BOLLARD TOP ASSEMBLY, DIAMONDS (1) USING HARDWARE (6). SQUARE AND TIGHTEN ALL HARDWARE.

STEP 3:

USE 1 - PC. 36" STL HEX BOLLARD MID SECTION ASSEMBLY (3)
 3 - PCS. 5/16" X 1/2" SS FLT SKT HD CAP SCREW (5)
 ATTACH 36" HEX BOLLARD MID SECTION ASSEMBLY (3) TO HEX BOLLARD BASE FOR SECURITY USING HARDWARE (5).

STEP 4:

USE 3 - PCS. 5/16" X 1/2" SS FLT SKT HD CAP SCREW (5)
 ATTACH STEP 2 ASSEMBLY TO STEP 3 ASSEMBLY USING HARDWARE (5).

NOTES:

- 1.) DURING ASSEMBLY PROCEDURE; DO NOT COMPLETELY TIGHTEN HARDWARE. EXCEPTION IS STEP 2.
- 2.) UPON COMPLETION OF BOLLARD ASSEMBLY SQUARE AND TIGHTEN ALL HARDWARE.
- 3.) THE ACTUAL PARTS WILL NOT BE NUMBERED; NUMBERS ONLY APPLY TO DRAWING.

ITEM	QTY	PART NO	DESCRIPTION
1	1	0-450-01-TA	STL HEX BOLLARD TOP ASSEMBLY, DIAMONDS
2	1	0-450-36/S-1X	36" STL HEX BOLLARD BASE FOR SECURITY
3	1	0-450-36-MA	36" STL HEX BOLLARD MID SECTION ASSEMBLY
4	1	0-450-C	STL HEX BOLLARD COVER
5	6	1-12-015	5/16" X 1/2" SS FLT SKT HD CAP SCR
6	2	1-12-069	5/16" X 3/4" SS BTN SKT HD CAP SCR

DuMor, inc.
 P.O. Box 142 Mifflintown, PA 17059-0142

SCALE : NONE
 DATE DRAWN : 11/1/05
 DRAWN BY : AWH
 DATE REV. : 3/30/06
 REV. BY : JSB

TITLE : BOLLARD
 REV. B
 DRAWING NUMBER 450-36-01/S-1X
 SHEET 2 OF 2