

NOTES

- 1.) STL MEMBERS COATED W/ ZINC RICH EPOXY THEN FINISHED W/ POLYESTER POWDER COATING.
- 2.) 1/2" X 3 3/4" EXPANSION ANCHOR BOLTS PROVIDED FOR S-2 OPTION.



DuMor, inc.

P.O. Box 142 Nifflintown, PA 17059-0142

SCALE : NONE

DATE DRAWN : 11/1/05

DRAWN BY : AWH

DATE REV. : 3/30/06

REV. BY : JSB

TITLE : BOLLARD

REV. B DRAWING NUMBER 450-42-01

SHEET 1 OF 2

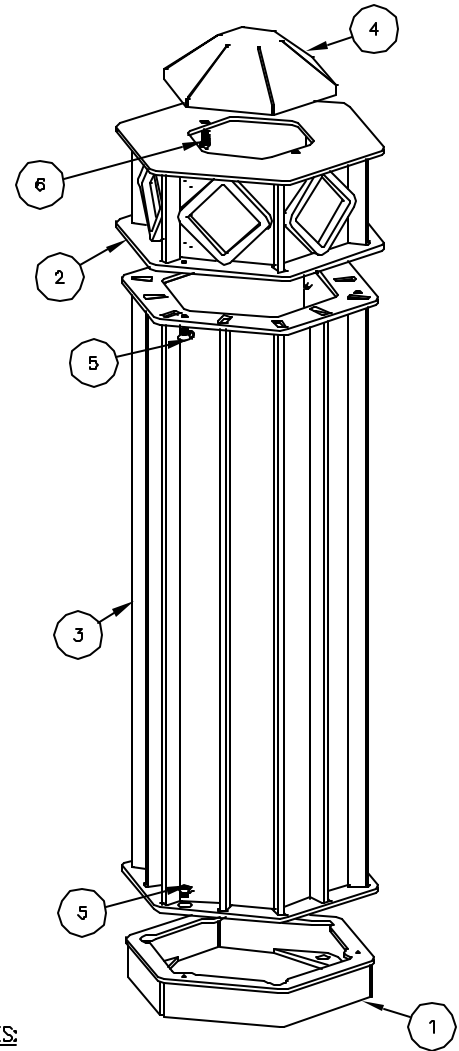
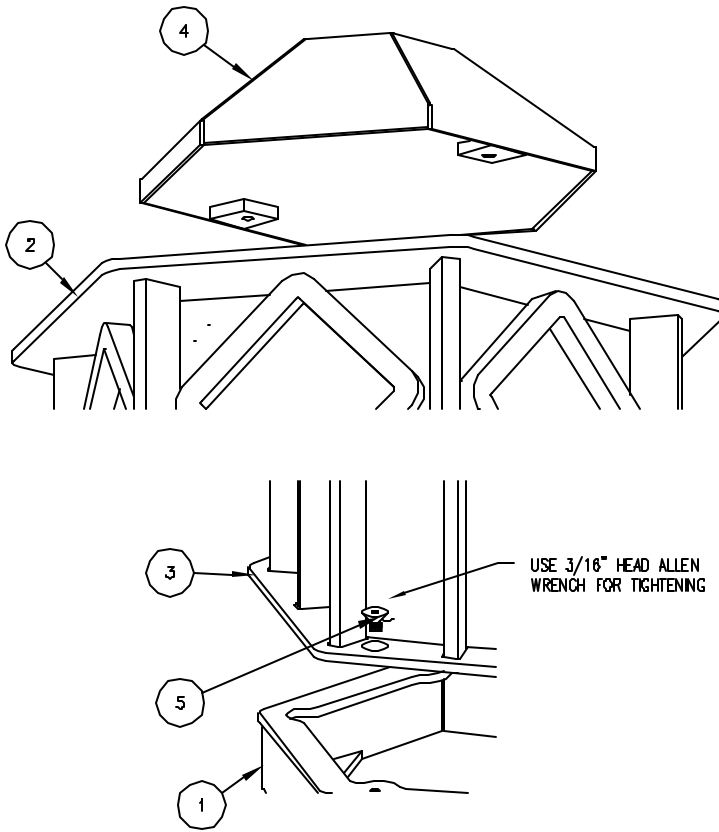

**STEP 1:**

USE 1 - PCS. STL HEX BOLLARD BASE ( 1 )  
 ANCHOR ACCORDING TO SUPPORT OPTION USED. LEVEL  
 AND SQUARE HEX BOLLARD BASE BEFORE ATTACHING  
 HEX BOLLARD MID SECTION ASSEMBLY. WHEN USING OVER  
 EXISTING BOLLARD, USE S-2 SUPPORT AND CENTER  
 EXISTING BOLLARD EVENLY IN THE MIDDLE OF HEX BOLLARD BASE.

**STEP 2:**

USE 1 - PCS. STL HEX BOLLARD TOP ASSEMBLY, DIAMONDS ( 2 )  
 1 - PCS. STL HEX BOLLARD COVER ( 4 )  
 2 - PCS. 5/16" X 3/4" SS BTN HD CAP SCREW ( 6 )  
 ATTACH STL HEX BOLLARD TOP ASSEMBLY,  
 DIAMONDS ( 2 ) USING HARDWARE ( 6 ). SQUARE AND TIGHTEN ALL HARDWARE.

**STEP 3:**

USE 1 - PCS. 42" STL HEX BOLLARD MID SECTION ASSEMBLY ( 3 )  
 3 - PCS. 5/16" X 1/2" SS FLT SKT HD CAP SCREW ( 5 )  
 ATTACH 42" HEX BOLLARD MID SECTION ASSEMBLY ( 3 ) TO  
 HEX BOLLARD BASE USING HARDWARE ( 5 ).

**STEP 4:**

USE 3 - PCS. 5/16" X 1/2" SS FLT SKT HD CAP SCREW ( 5 )  
 ATTACH STEP 2 ASSEMBLY TO STEP 3 ASSEMBLY USING  
 HARDWARE ( 5 ).

**NOTES:**

- 1.) DURING ASSEMBLY PROCEDURE;  
DO NOT COMPLETELY TIGHTEN HARDWARE.  
EXCEPTION IS STEP 1 & 2.
- 2.) UPON COMPLETION OF BOLLARD ASSEMBLY,  
SQUARE ALL COMPONENTS AND TIGHTEN  
ALL HARDWARE.
- 3.) THE ACTUAL PARTS WILL NOT BE NUMBERED;  
NUMBERS ONLY APPLY TO DRAWING.
- 4.) SEE SPEC. SHEET 1 FOR MOUNTING OPTION.
- 5.) INSTALLATION TIME MAY VARY DUE TO  
ANCHORING APPLICATIONS.
- 6.) FOR 1/2" EXPANSION ANCHORS USE 1/2" DIA.  
DRILL BIT TO DRILL INTO CONCRETE.

ITEM	QTY	PART NO	DESCRIPTION
1	1	0-450-00/S-2	STL HEX BOLLARD BASE
2	1	0-450-01-TA	STL HEX BOLLARD TOP ASSEMBLY, DIAMONDS
3	1	0-450-42-MA	42" STL HEX BOLLARD MID SECTION ASSEMBLY
4	1	0-450-C	STL HEX BOLLARD COVER
5	6	1-12-015	5/16" X 1/2" SS FLT SKT HD CAP SCR
6	2	1-12-069	5/16" X 3/4" SS BTN SKT HD CAP SCR

**DuMor, inc.**  
 P.O. Box 142 Mifflintown, PA 17059-0142

SCALE : NONE  
 DATE DRAWN : 11/1/05  
 DRAWN BY : AWH  
 DATE REV. : 3/30/06  
 REV. BY : JSB

TITLE : BOLLARD

REV. B	DRAWING NUMBER 450-42-01	SHEET 2 OF 2
--------	--------------------------	--------------