

S-2 SURFACE

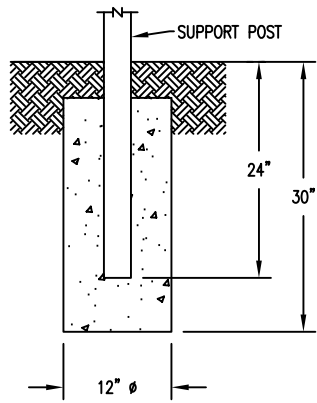

S-1 EMBEDMENT

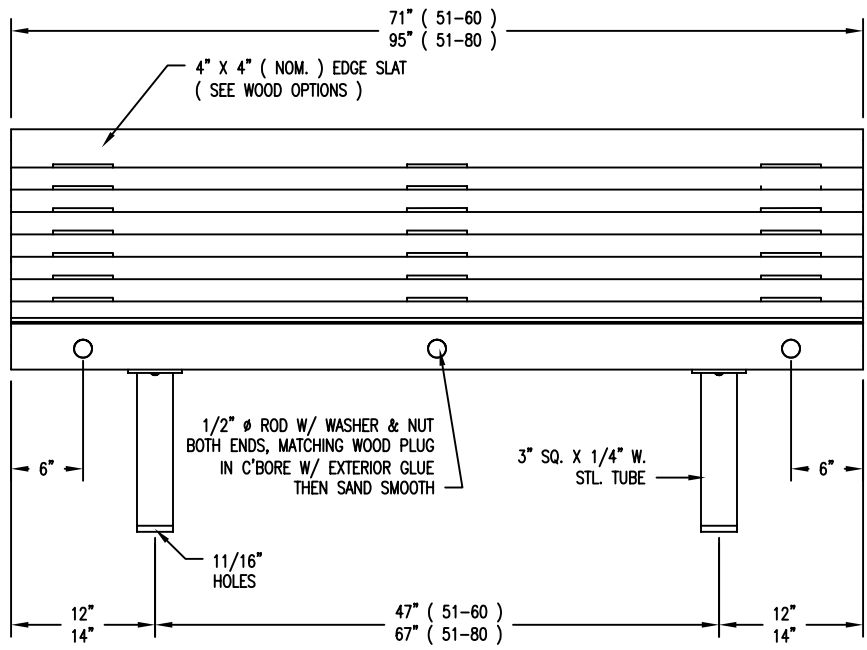
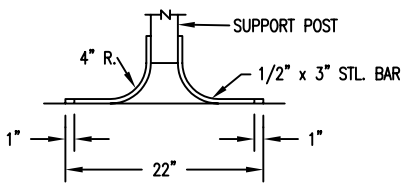
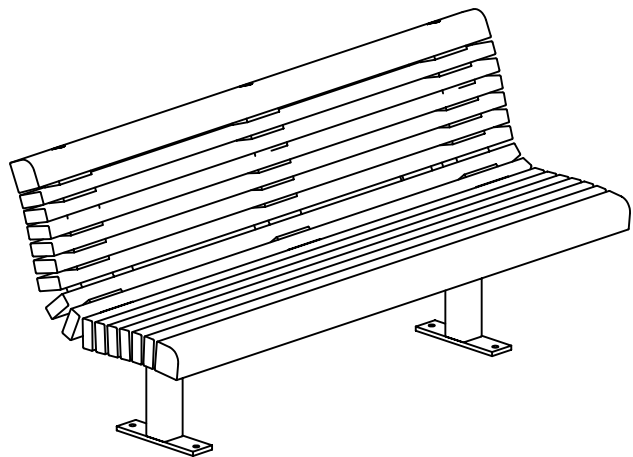

S-3 GULL WING

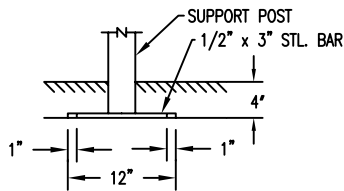

S-4 SUB FLOOR

LENGTH OPTIONS

- 6' BENCH
- 8' BENCH

WOOD OPTIONS

- CLEAR ALL HEART REDWOOD S4S EE
- 'C' & BTR. DOUGLAS FIR KD S4S EE
- OTHER \_\_\_\_\_

NOTES

- 1.) ALL STL. MEMBERS COATED W/ ZINC RICH EPOXY THEN FINISHED W/ POLYESTER POWDER COATING.
- 2.) ALL WOOD MEMBERS TREATED W/ CLEAR PRESERVATIVE.
- 3.) 1/2" X 3 3/4" ANCHOR BOLTS PROVIDED FOR S-2, S-3 & S-4 OPTIONS.

 DuMor, inc. P.O. Box 142 Mifflintown, PA 17059-0142	SCALE :	NONE	TITLE :		BENCH
	DATE DRAWN :	3/22/94	REV.	D	DRAWING NUMBER
	DRAWN BY :	AH			
	DATE REV. :	12/15/08			
REV. BY :	ESS		51 SERIES	SHEET 1 OF 2	

SURFACE MOUNT  
OPTION SHOWN

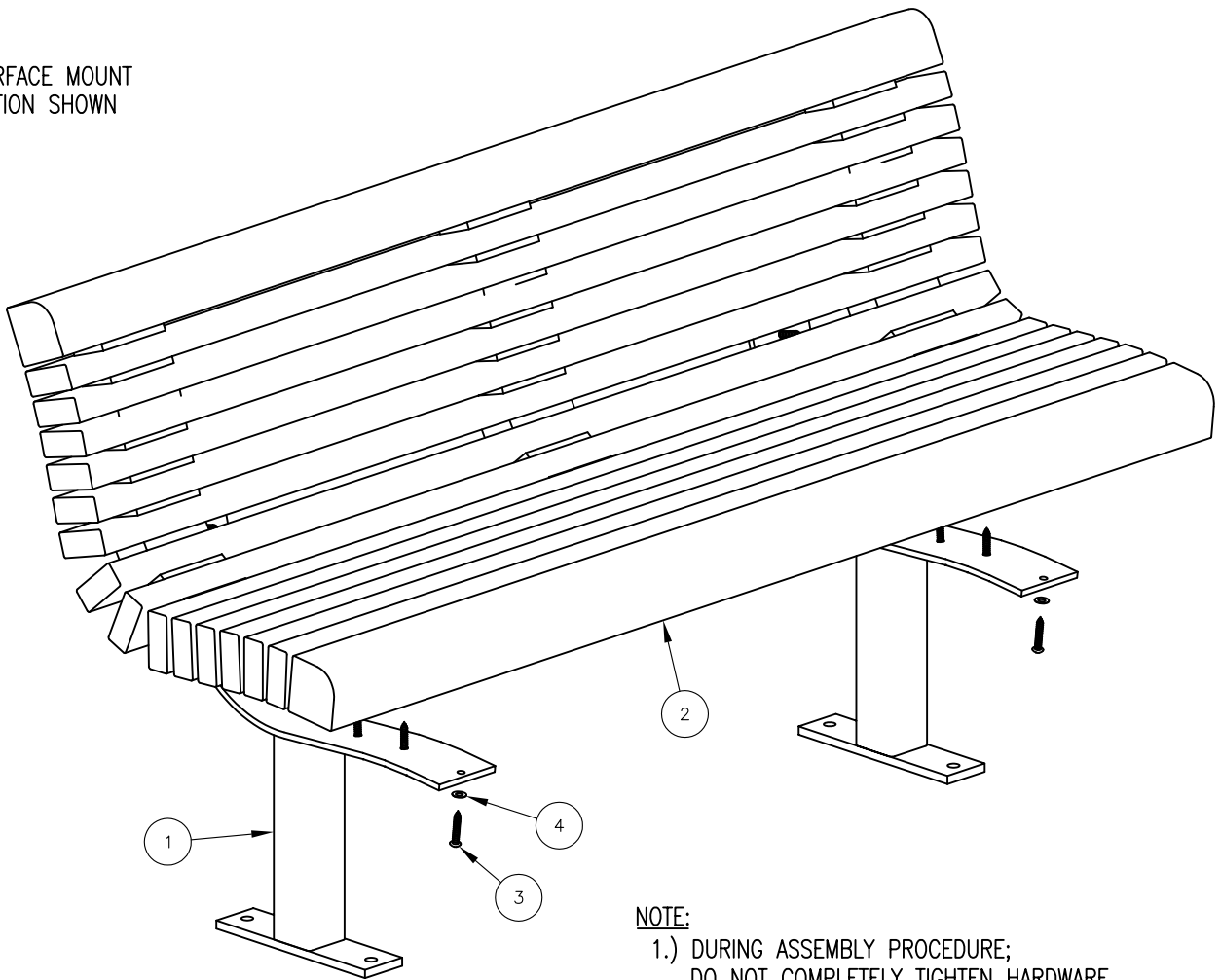

**NOTE:**

- 1.) DURING ASSEMBLY PROCEDURE;  
DO NOT COMPLETELY TIGHTEN HARDWARE.
- 2.) THE ACTUAL PARTS WILL NOT BE NUMBERED:  
NUMBERS ONLY APPLY TO DRAWING.
- 3.) SEE SPEC. SHEET 1 FOR MOUNTING OPTION.

**STEP 1:**

- USE 2 - PCS. SUPPORT FOR SURFACE MOUNT ( 1 )
- 1 - PC. 6' SEAT ASSEMBLY ( 2 )
- 16 - PCS. 3/8" X 2" SS. BTN. SKT. HD. LAG SCR. ( 3 )
- 16 - PCS. 3/8" SS. FLAT WASHER ( 4 )

ATTACH SUPPORTS FOR SURFACE MOUNT ( 1 ) TO 6' SEAT ASSEMBLY ( 2 ) USING HARDWARE ( 3 & 4 ). TIGHTEN TO SNUG FIT.

**STEP 2:**

UPON COMPLETION OF BENCH ASSEMBLY SQUARE ALL COMPONENTS THEN TIGHTEN ALL HARDWARE.

**STEP 3:**

ANCHOR ACCORDING TO SUPPORT OPTION USED.

ITEM	QTY	PART NO	DESCRIPTION
1	2	0-51-00-01/S-2	SUPPORT FOR SURFACE MT
2	1	0-51-60-02	6' SEAT ASSEMBLY
3	16	1-13-016	3/8" X 2" SS BTN SKT HD LAG SCR
4	16	1-22-024	3/8" SS FLAT WASHER

**DuMor, inc.**  
P.O. Box 142 Mifflintown, PA 17059-0142

SCALE : NONE  
DATE DRAWN : 3/22/94  
DRAWN BY : AH  
DATE REV. : 12/15/08  
REV. BY : ESS

TITLE : BENCH ASSEMBLY

REV. D

DRAWING NUMBER

51 SERIES

SHEET 2 OF 2