

NOTES

- 1.) ALL STL. MEMBERS COATED W/ ZINC RICH EPOXY THEN FINISHED W/ POLYESTER POWDER COATING.
- 2.) 1/2" X 3 3/4" EXPANSION ANCHOR BOLTS PROVIDED.
- 3.) CUSTOM LETTERING AVAILABLE FOR RECESSED SIDE PANELS (TOTAL OF 37 SPACES)

CUSTOM LETTERING (37 SPACES)

LENGTH OPTIONS

- 6' BENCH
- 8' BENCH

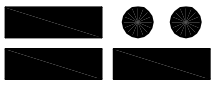
 DuMor, inc. P.O. Box 142 Mifflintown, PA 17059-0142	SCALE :	NONE	TITLE :		BENCH	
	DATE DRAWN :	3/22/94	REV.	DRAWING NUMBER	58 SERIES	SHEET 1 OF 2
	DRAWN BY :	AH	D			
	DATE REV. :	11/21/99				
	REV. BY :	JSB				

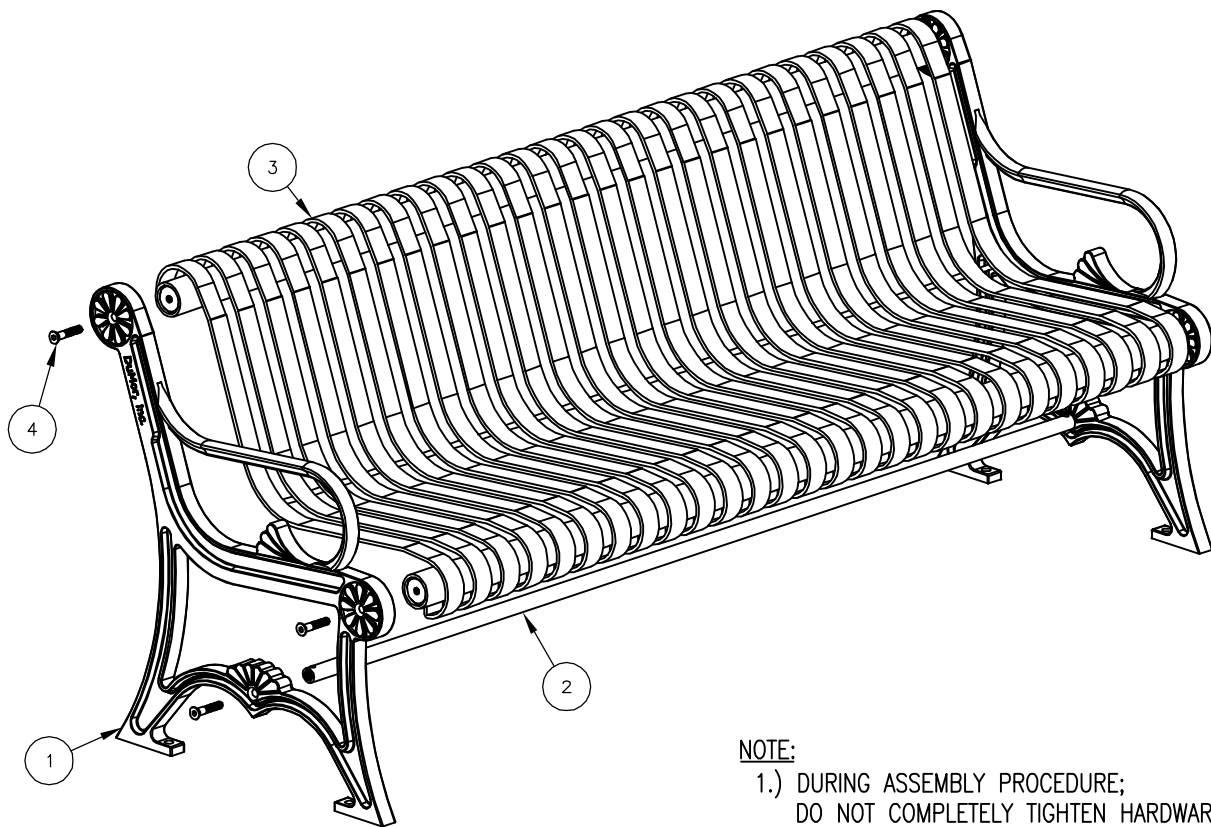

NOTE:

- 1.) DURING ASSEMBLY PROCEDURE;
DO NOT COMPLETELY TIGHTEN HARDWARE.
- 2.) THE ACTUAL PARTS WILL NOT BE NUMBERED:
NUMBERS ONLY APPLY TO DRAWING.

STEP 1:

USE 2 - PCS. CAST IRON BENCH SUPPORT (1)
 1 - PC. 6' ALL STL. SEAT ASSEMBLY (3)
 4 - PC. 1/2" X 2 1/2" FLT. SKT. HD. CAP SCR. (4)
 ATTACH CAST IRON BENCH SUPPORT (1) TO 6' ALL STL.
 SEAT ASSEMBLY (3) USING HARDWARE (4).
 TIGHTEN TO SNUG FIT.

STEP 2:

USE 1 - PC. 71 3/4" PIPE BRACE (2)
 2 - PCS. 1/2" X 2 1/2" FLT. SKT. HD. CAP SCR. (4)
 ATTACH 71 3/4" PIPE BRACE (2) TO STEP 1 ASSEMBLY
 USING HARDWARE (4). TIGHTEN TO SNUG FIT.

STEP 3:

UPON COMPLETION OF BENCH ASSEMBLY SQUARE ALL
 COMPONENTS THEN TIGHTEN ALL HARDWARE.

STEP 4:

MOUNT AND ANCHOR AS SPECIFIED.

ITEM	QTY	PART NO	DESCRIPTION
1	2	0-57-00-02	CAST IRON BENCH SUPPORT
2	1	0-57-60-04	71 3/4" PIPE BRACE
3	1	0-58-60-01	6' STL SEAT
4	6	1-12-065	1/2" X 2 1/2" FLT SKT HD CAP SCR

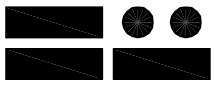
 DuMor, inc. P.O. Box 142 Mifflintown, PA 17059-0142	SCALE :	NONE	TITLE : BENCH ASSEMBLY		
	DATE DRAWN :	3/22/94			
	DRAWN BY :	AH	REV. : D	DRAWING NUMBER 58 SERIES	SHEET 2 OF 2
	DATE REV. :	11/21/99			
REV. BY :	JSB				