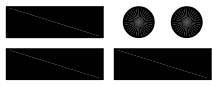

FINISH OPTIONS:

- ALL STL. MEMBERS COATED W/ ZINC RICH EPOXY THEN FINISHED W/ POLYESTER POWDER COATING.
- HOT DIP GALV. AFTER FABRICATION.

LENGTH OPTIONS

- 6' TABLE
- 8' TABLE

 DuMor, inc. P.O. Box 142 Mifflintown, PA 17059-0142	SCALE :	NONE	TITLE :		PICNIC TABLE	
	DATE DRAWN :	3/22/94	REV.	DRAWING NUMBER	71 SERIES A	SHEET 1 OF 2
	DRAWN BY :	CDC	F			
	DATE REV. :	11/10/08				
REV. BY :	ESS					

NOTE:

- 1.) DURING ASSEMBLY PROCEDURE;
DO NOT COMPLETELY TIGHTEN HARDWARE.
- 2.) THE ACTUAL PARTS WILL NOT BE NUMBERED;
NUMBERS ONLY APPLY TO DRAWING.

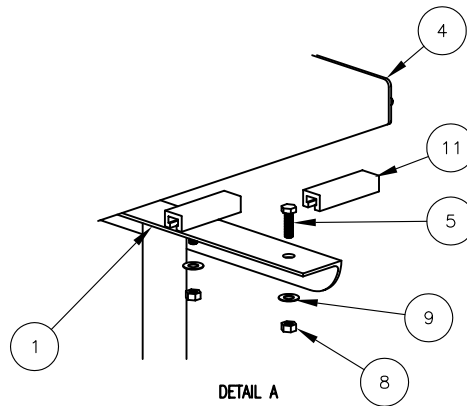
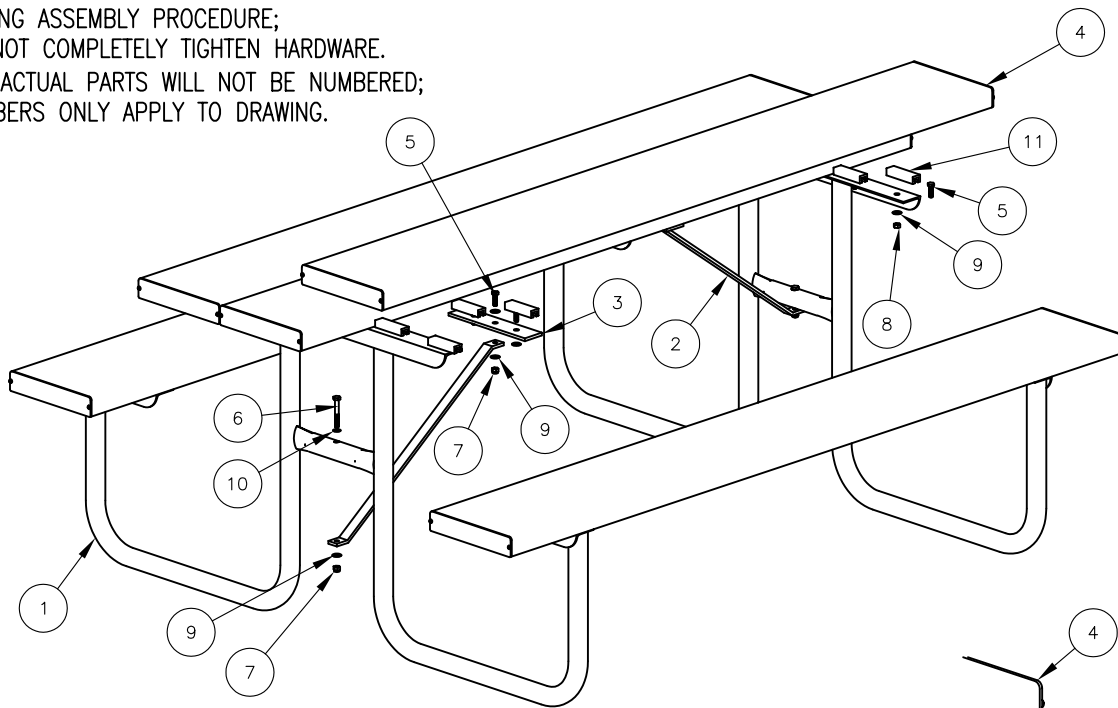

STEP 1:

- USE 5 - PCS. 2" X 10" X 6' ALUMINUM SLAT (4)
- 2 - PCS. END SUPPORT FRAME (1)
- 20 - PCS. ALUMINUM CLIPS (11)
- 20 - PCS. 5/16" X 1" SS. HEX HD. CAP SCR. (5)
- 20 - PCS. 5/16" SS. HEX NUT (8)
- 20 - PCS. 5/16" SS. FLAT WASHER (9)

PLACE ALUMINUM CLIP (11) OVER HEAD OF 5/16" X 1" SS. HEX HD. CAP SCR. (5). PLACE BOLT WITH CLIP IN END SUPPORT FRAME (1) THEN PLACE 2" X 10" ALUMINUM PLANKS (4) ON SUPPORTS OVER TOP OF ALUMINUM CLIP. TURN CLIP 1/4 TURN IN ALUMINUM PLANK TO LOCK INTO PLACE. THEN USE HARDWARE (8 & 9) TO TIGHTEN TO SNUG FIT.

STEP 2:

- USE 2 - PCS. DIAGONAL BRACE (2)
- 2 - PCS. BOLT PLATE FOR ALUM PLANK (3)
- 2 - PCS. 5/16" X 1" SS. HEX HD. CAP SCR. (5)
- 2 - PCS. 5/16" SS. NYLON LOCK NUT (7)
- 4 - PCS. 5/16" SS. FLAT WASHERS (9)

ATTACH BOLT PLATE FOR ALUM PLANK (3) TO DIAGONAL BRACE (2) USING HARDWARE (5, 7 & 9). TIGHTEN TO SNUG FIT.

STEP 3:

- USE 2 - PCS. 5/16" X 2 1/2" SS. HEX HD. CAP SCR. (6)
- 2 - PCS. 5/16" SS. NYLON LOCK NUT (7)
- 2 - PCS. 5/16" SS. FLAT WASHERS (9)
- 2 - PCS. 3/8" X 5/8" RUBBER WASHER (10)

ATTACH STEP 2 ASSEMBLIES TO STEP 1 ASSEMBLY USING HARDWARE (6, 7, 9 & 10). TIGHTEN TO SNUG FIT.

STEP 4:

- USE 4 - PCS. ALUMINUM CLIPS (11)
- 4 - PCS. 5/16" X 1" SS. HEX HD. CAP SCR. (5)
- 4 - PCS. 5/16" SS. HEX NUT (8)
- 4 - PCS. 5/16" SS. FLAT WASHER (9)

PLACE ALUMINUM CLIP (11) OVER HEAD OF 5/16" X 1" SS. HEX HD. CAP SCR. (5). PLACE BOLT WITH CLIP IN BRACE BOLT PLATE (3), THEN TURN CLIP 1/4 TURN IN ALUMINUM PLANK TO LOCK INTO PLACE. USING HARDWARE (8 & 9) TIGHTEN TO SNUG FIT.

STEP 5:

UPON COMPLETION OF TABLE ASSEMBLY SQUARE ALL COMPONENTS THEN TIGHTEN ALL HARDWARE.

ITEM	QTY	PART NO	DESCRIPTION
1	2	0-71-00-02	END SUPPORT FRAME
2	2	0-71-00-03	DIAGONAL BRACE
3	2	0-71-00-08	BOLT PLATE FOR ALUM PLANK
4	5	0-71-60A-01	2" X 10" X 6' ALUMINUM PLANK
5	26	1-12-061	5/16" X 1" SS HEX HD CAP SCR
6	2	1-12-079	5/16" X 2 1/2" SS HEX HD CAP SCR
7	4	1-20-016	5/16" SS NYLON LOCKNUT
8	24	1-21-015	5/16" SS HEX NUT
9	30	1-22-017	5/16" SS FLAT WASHER
10	2	1-22-018	3/8" ID X 5/8" OD RUBBER WASHER
11	24	5-48-083	ALUMINUM CLIPS

DuMor, inc.
P.O. Box 142 Mifflintown, PA 17059-0142

SCALE : NONE
DATE DRAWN : 3/22/94
DRAWN BY : CDC
DATE REV. : 11/10/08
REV. BY : ESS

TITLE : PICNIC TABLE ASSEMBLY
REV. F
DRAWING NUMBER 71 SERIES A
SHEET 2 OF 2