

LENGTH OPTIONS

- 6' TABLE
- 8' TABLE

FINISH OPTIONS:

- ALL STL. MEMBERS COATED W/ ZINC RICH EPOXY THEN FINISHED W/ POLYESTER POWDER COATING.
- HOT DIP GALV. AFTER FABRICATION.

SLAT OPTIONS

- "CEDAR" RECYCLED PLASTIC
- "GREEN" RECYCLED PLASTIC
- "GREY" RECYCLED PLASTIC
- "REDWOOD" RECYCLED PLASTIC
- "WALNUT" RECYCLED PLASTIC
- OTHER _____

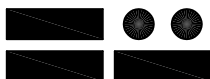

DuMor, inc.

P.O. Box 142 Mifflintown, PA 17059-0142

SCALE : NONE
 DATE DRAWN : 3/22/94
 DRAWN BY : CDC
 DATE REV. : 12/02/09
 REV. BY : ESS

TITLE : PICNIC TABLE

REV. F

DRAWING NUMBER 71 SERIES PL

SHEET 1 OF 2

NOTE:

- 1.) DURING ASSEMBLY PROCEDURE;
DO NOT COMPLETELY TIGHTEN HARDWARE.
- 2.) THE ACTUAL PARTS WILL NOT BE NUMBERED;
NUMBERS ONLY APPLY TO DRAWING.

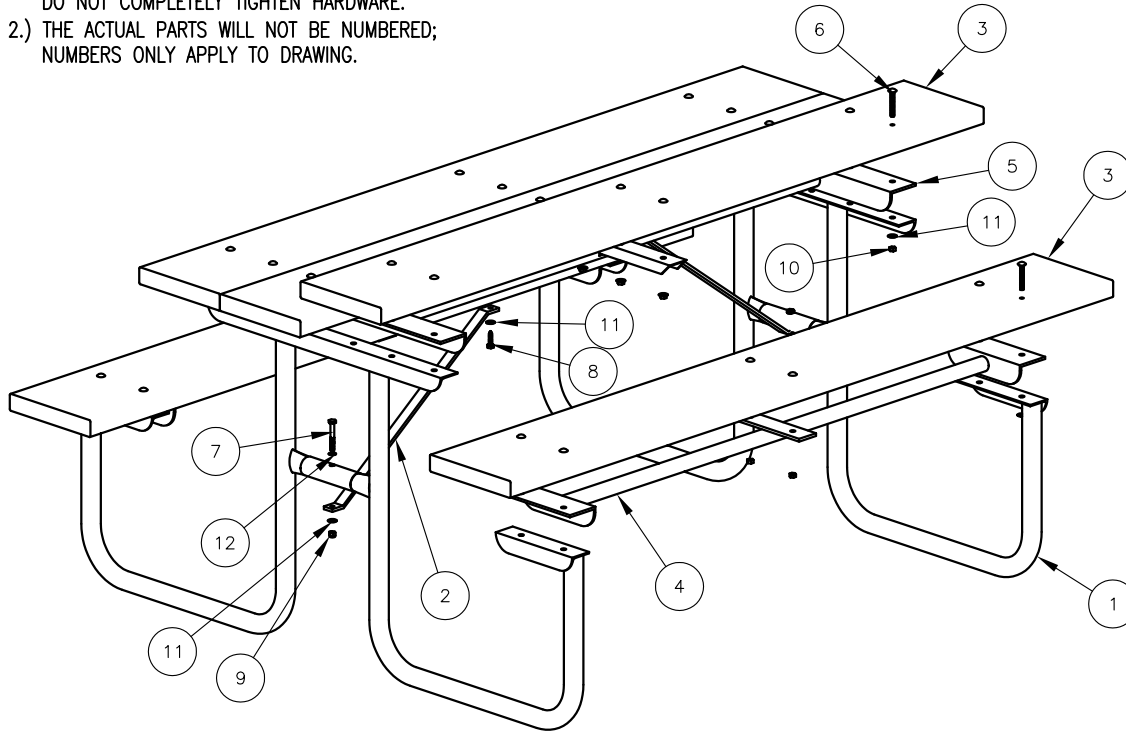

STEP 1:

- USE 3 - PCS. 2" X 10" X 71" PLASTIC SLATS (3)
 1 - PC. 6' TABLE TOP BRACE (5)
 6 - PCS. 5/16" X 2 1/4" SS CGE. BOLT (6)
 6 - PCS. 5/16" SS HEX NUT (10)
 6 - PCS. 5/16" SS FLAT WASHER (11)
 ATTACH 2" X 10" X 71" PLASTIC SLATS (3) TO CENTER OF 6' TABLE TOP BRACE (5) USING HARDWARE (6, 10, & 11). TIGHTEN TO SNUG FIT. REPEAT UNTIL ALL SLATS ARE ATTACHED.

STEP 2:

- USE 2 - PCS. END SUPPORT FRAME (1)
 12 - PCS. 5/16" X 2 1/4" SS CGE. BOLT (6)
 12 - PCS. 5/16" SS HEX NUT (10)
 12 - PCS. 5/16" SS FLAT WASHER

ATTACH 2" X 10" X 71" PLASTIC SLATS (3) TO CENTER OF 6' SEAT BRACE (4) USING HARDWARE (6, 10, & 11). TIGHTEN TO SNUG FIT.

STEP 4:

- USE 8 - PCS. 5/16" X 2 1/4" SS CGE. BOLT (6)
 8 - PCS. 5/16" SS HEX NUT (10)
 8 - PCS. 5/16" SS FLAT WASHER (11)
 ATTACH STEP 3 ASSEMBLY TO STEP 2 ASSEMBLY USING HARDWARE (6, 10, & 11). TIGHTEN TO SNUG FIT.

STEP 5:

- USE 2 - PCS. DIAGONAL BRACE (2)
 2 - PCS. 5/16" X 2 1/2" SS HEX HD CAP SCR. (7)
 2 - PCS. 5/16" X 1 1/4" SS HEX HD LAG SCR. (8)
 2 - PCS. 5/16" SS NYLON LOCK NUT (9)
 4 - PCS. 5/16" SS FLAT WASHER (11)
 2 - PCS. 3/8" ID X 5/8" OD RUBBER WASHER (12)
 SQUARE STEP 4 ASSEMBLY THEN ATTACH DIAGONAL BRACE (2) USING HARDWARE (7, 8, 9, 11, & 12). NO PILOT HOLES FOR 5/16" X 1 1/4" SS HEX HD LAG SCR. (8).

STEP 6:

UPON COMPLETION OF TABLE ASSEMBLY TIGHTEN ALL HARDWARE.

ITEM	QTY	PART NO	DESCRIPTION
1	2	0-71-00-02	END SUPPORT FRAME
2	2	0-71-00-03	DIAGONAL BRACE
3	5	0-71-60PL-01	2" X 10" X 71" PLASTIC SLAT
4	2	0-77-60-14	6' SEAT BRACE
5	1	0-77-60-15	6' TABLE TOP BRACE
6	30	1-11-062	5/16" X 2 1/4" SS CGE BOLT
7	2	1-12-079	5/16" X 2 1/2" SS HEX HD CAP SCR
8	2	1-13-001	5/16" X 1 1/4" SS HEX HD LAG SCR
9	2	1-20-016	5/16" SS NYLON LOCKNUT
10	30	1-21-015	5/16" SS HEX NUT
11	34	1-22-017	5/16" SS FLAT WASHER
12	2	1-22-018	3/8" ID X 5/8" OD RUBBER WASHER

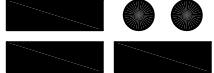
 DuMor, inc. P.O. Box 142 Mifflintown, PA 17059-0142	SCALE : NONE	TITLE : PICNIC TABLE ASSEMBLY	
	DATE DRAWN : 3/22/94	REV. F	DRAWING NUMBER 71 SERIES PL
	DRAWN BY : CDC		
	DATE REV. : 12/02/09		
REV. BY : ESS	SHEET 2 OF 2		