

FINISH OPTIONS:

- ALL STL. MEMBERS COATED W/ ZINC RICH EPOXY THEN FINISHED W/ POLYESTER POWDER COATING.
- HOT DIP GALV. AFTER FABRICATION.

NOTE:

- 1.) 1/4" X 1 1/2" HAMMERSET ANCHORS AND 1 1/4" PIPE CLAMPS PROVIDED ( 4 - PCS )

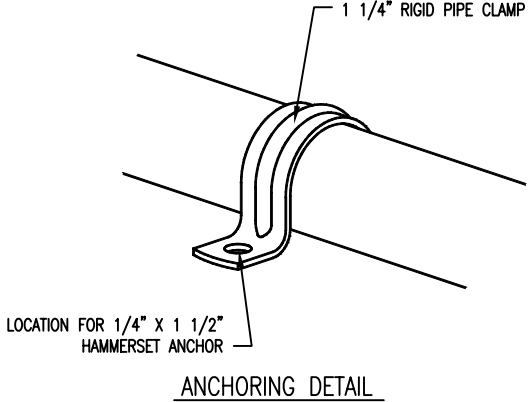

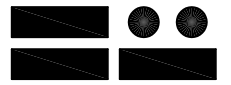
 <p><b>DuMor, inc.</b> P.O. Box 142 Mifflintown, PA 17059-0142</p>	SCALE :	NONE	TITLE :		PICNIC TABLE
	DATE DRAWN :	3/22/94	REV.	DRAWING NUMBER	
	DRAWN BY :	CDC	G	71-68-1A	SHEET
	DATE REV. :	11/12/08	REV. BY :	ESS	1 OF 2

**NOTE:**

- 1.) DURING ASSEMBLY PROCEDURE;  
DO NOT COMPLETELY TIGHTEN HARDWARE.
- 2.) THE ACTUAL PARTS WILL NOT BE NUMBERED;  
NUMBERS ONLY APPLY TO DRAWING.
- 3.) SEE SPEC. SHEET 1 FOR MOUNTING DETAILS

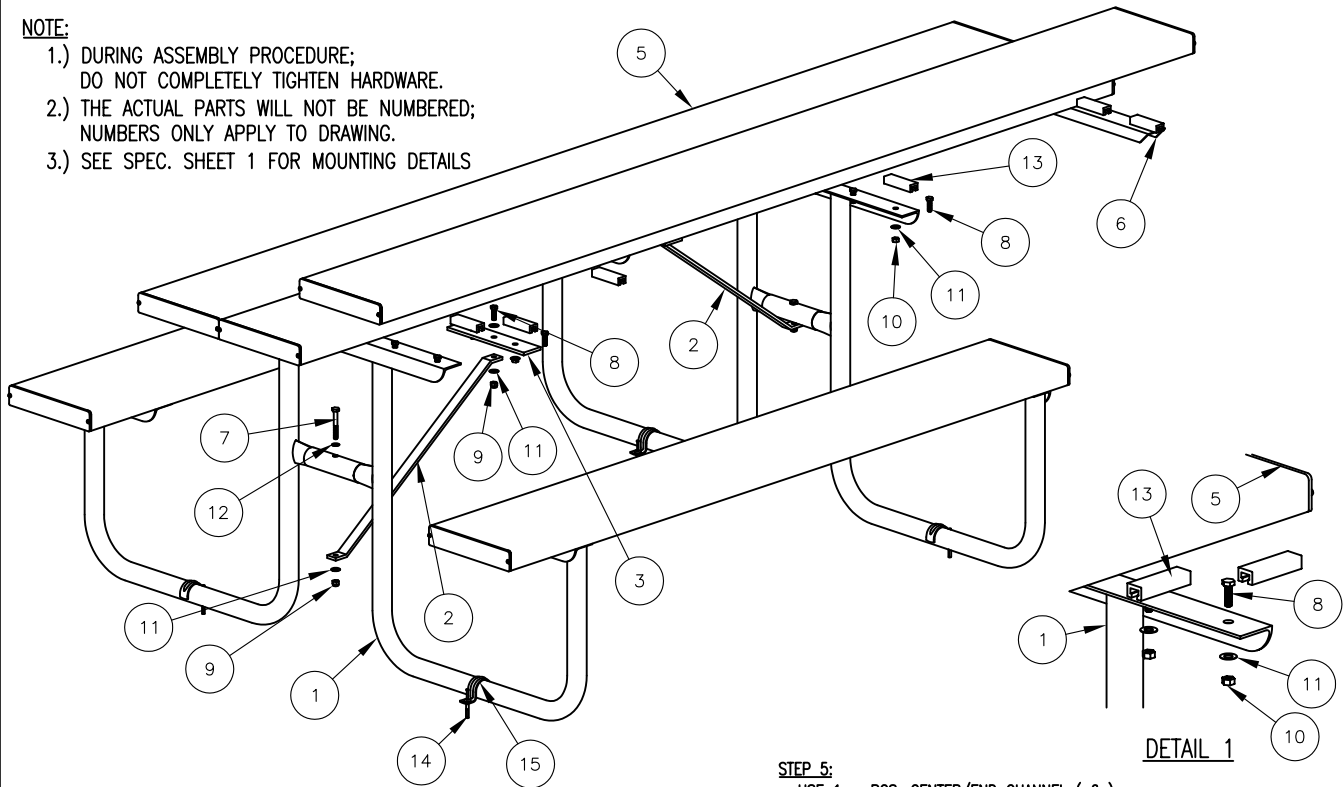

**STEP 1:**

- USE 3 - PCS. 2" X 10" X 8' ALUMINUM SLAT ( 5 )  
 2 - PCS. 2" X 10" X 66" ALUMINUM SLAT ( 4 )  
 2 - PCS. END SUPPORT FRAME ( 1 )  
 20 - PCS. ALUMINUM CLIPS ( 13 )  
 20 - PCS. 5/16" X 1" SS. HEX HD. CAP SCR. ( 8 )  
 20 - PCS. 5/16" SS. HEX NUT ( 10 )  
 20 - PCS. 5/16" SS. FLAT WASHER ( 11 )
- PLACE ALUMINUM CLIP ( 13 ) OVER HEAD OF 5/16" X 1" SS. HEX HD. CAP SCR. ( 8 ). PLACE BOLT WITH CLIP IN END SUPPORT FRAME ( 1 ) THEN PLACE 2" X 10" ALUMINUM PLANKS ( 4 & 5 ) ON SUPPORTS OVER TOP OF ALUMINUM CLIP. TURN CLIP 1/4 TURN IN ALUMINUM PLANK TO LOCK INTO PLACE. THEN USE HARDWARE ( 10 & 11 ) TO TIGHTEN TO SNUG FIT. ( SEE DETAIL 1 )

**STEP 2:**

- USE 2 - PCS. DIAGONAL BRACE ( 2 )  
 2 - PCS. BOLT PLATE FOR ALUM PLANK ( 3 )  
 2 - PCS. 5/16" X 1" SS. HEX HD. CAP SCR. ( 8 )  
 2 - PCS. 5/16" SS. NYLON LOCK NUT ( 9 )  
 4 - PCS. 5/16" SS. FLAT WASHERS ( 11 )
- ATTACH BOLT PLATE FOR ALUM PLANK ( 3 ) TO DIAGONAL BRACE ( 2 ) USING HARDWARE ( 8, 9 & 11 ). TIGHTEN TO SNUG FIT.

**STEP 3:**

- USE 2 - PCS. 5/16" X 2 1/2" SS. HEX HD. CAP SCR. ( 7 )  
 2 - PCS. 5/16" SS. NYLON LOCK NUT ( 9 )  
 2 - PCS. 5/16" SS. FLAT WASHERS ( 11 )  
 2 - PCS. 3/8" X 5/8" RUBBER WASHER ( 12 )
- ATTACH STEP 2 ASSEMBLIES TO STEP 1 ASSEMBLY USING HARDWARE ( 7, 9, 11 & 12 ). TIGHTEN TO SNUG FIT.

**STEP 4:**

- USE 4 - PCS. ALUMINUM CLIPS ( 13 )  
 4 - PCS. 5/16" X 1" SS. HEX HD. CAP SCR. ( 8 )  
 4 - PCS. 5/16" SS. HEX NUT ( 10 )  
 4 - PCS. 5/16" SS. FLAT WASHER ( 11 )
- PLACE ALUMINUM CLIP ( 13 ) OVER HEAD OF 5/16" X 1" SS. HEX HD. CAP SCR. ( 8 ). PLACE BOLT WITH CLIP IN BRACE BOLT PLATE THEN TURN CLIP 1/4 TURN IN ALUMINUM PLANK TO LOCK INTO PLACE. THEN USE HARDWARE ( 10 & 11 ) TO TIGHTEN TO SNUG FIT.

**STEP 5:**

- USE 1 - PCS. CENTER/END CHANNEL ( 6 )  
 6 - PCS. ALUMINUM CLIPS ( 13 )  
 6 - PCS. 5/16" X 1" SS. HEX HD. CAP SCR. ( 8 )  
 6 - PCS. 5/16" SS. HEX NUT ( 10 )  
 6 - PCS. 5/16" SS. FLAT WASHER ( 11 )
- PLACE ALUMINUM CLIP ( 13 ) OVER HEAD OF 5/16" X 1" SS. HEX HD. CAP SCR. ( 8 ). PLACE BOLT WITH CLIP IN CENTER/END CHANNEL ( 6 ) TURN CLIP 1/4 TURN IN ALUMINUM PLANK TO LOCK INTO PLACE. THEN USE HARDWARE ( 10 & 11 ) TO TIGHTEN TO SNUG FIT.

**STEP 6:**

UPON COMPLETION OF TABLE ASSEMBLY SQUARE ALL COMPONENTS THEN TIGHTEN ALL HARDWARE.

**STEP 7:**

- 4 - PCS. 1/4" X 1 1/2" HAMMERSET ANCHORS ( 14 )  
 4 - PCS. 1 1/4" RIGID PIPE CLAMP ( 15 )
- PLACE TABLE IN SITE LOCATION DESIRED. PLACE 1 1/4" RIGID PIPE CLAMP IN CENTER OF TABLE LEGS. MARK HOLES AND MOVE 1 1/4" RIGID PIPE CLAMPS. DRILL 1/4" DIA HOLE IN CONCRETE AT MARKED HOLE LOCATIONS APPROX. 2" DEEP. BLOW OUT DUST IN DRILLED HOLES. PLACE 1 1/4" RIGID PIPE CLAMPS IN OVER TABLE LEGS AND IN LINE WITH DRILLED HOLES. PLACE 1/4" X 1 1/2" HAMMERSET ANCHORS IN HOLES AND DRIVE IN WITH HAMMER.

ITEM	QTY	PART NO	DESCRIPTION
1	2	0-71-00-02	END SUPPORT FRAME
2	2	0-71-00-03	DIAGONAL BRACE
3	2	0-71-00-08	BOLT PLATE FOR ALUM PLANK
4	2	0-71-68-1A-01	2" X 10" X 66" ALUMINUM PLANK
5	3	0-71-80A-01	2" X 10" X 8" ALUMINUM PLANK
6	1	0-77-00-03	CENTER/END CHANNEL
7	2	1-12-079	5/16" X 2 1/2" SS HEX HD CAP SCR
8	32	1-12-061	5/16" X 1" SS HEX HD CAP SCR
9	4	1-20-016	5/16" SS NYLON LOCKNUT
10	30	1-21-015	5/16" SS HEX NUT
11	36	1-22-017	5/16" SS FLAT WASHER
12	2	1-22-018	3/8" ID X 5/8" OD RUBBER WASHER
13	30	5-48-083	ALUMINUM CLIPS
14	4	1-17-021	1/4" X 1 1/2" SS HAMMERSET ANCHOR
15	4	5-48-491	1 1/4" RIGID PIPE CLAMP, 3/8" DIA HOLE, PLTD

**DuMor, inc.**

P.O. Box 142 Mifflintown, PA 17059-0142

SCALE : NONE  
 DATE DRAWN : 3/22/94  
 DRAWN BY : CDC  
 DATE REV. : 11/12/08  
 REV. BY : ESS

TITLE : PICNIC TABLE ASSEMBLY

REV. G DRAWING NUMBER 71-68-1A

SHEET 2 OF 2