

LENGTH OPTIONS

- 6' TABLE
- 8' TABLE

WOOD OPTIONS

- #1 SOUTHERN YELLOW PINE S4S EE
- 'C' & BTR. DOUGLAS FIR KD S4S EE
- OTHER \_\_\_\_\_

NOTE:

1.) ALL DOUGLAS FIR WOOD MEMBERS TREATED WITH CLEAR PRESERVATIVE.

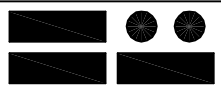

**DuMor, inc.**  
 P.O. Box 142 Mifflintown, PA 17059-0142

SCALE :	NONE
DATE DRAWN :	3/22/94
DRAWN BY :	AH
DATE REV. :	10/4/06
REV. BY :	AWH

TITLE :	PICNIC TABLE	
REV. :	DRAWING NUMBER	SHEET
F	72 SERIES	1 OF 2

**NOTE:**

- 1.) DURING ASSEMBLY PROCEDURE;  
DO NOT COMPLETELY TIGHTEN HARDWARE.
- 2.) THE ACTUAL PARTS WILL NOT BE NUMBERED;  
NUMBERS ONLY APPLY TO DRAWING.

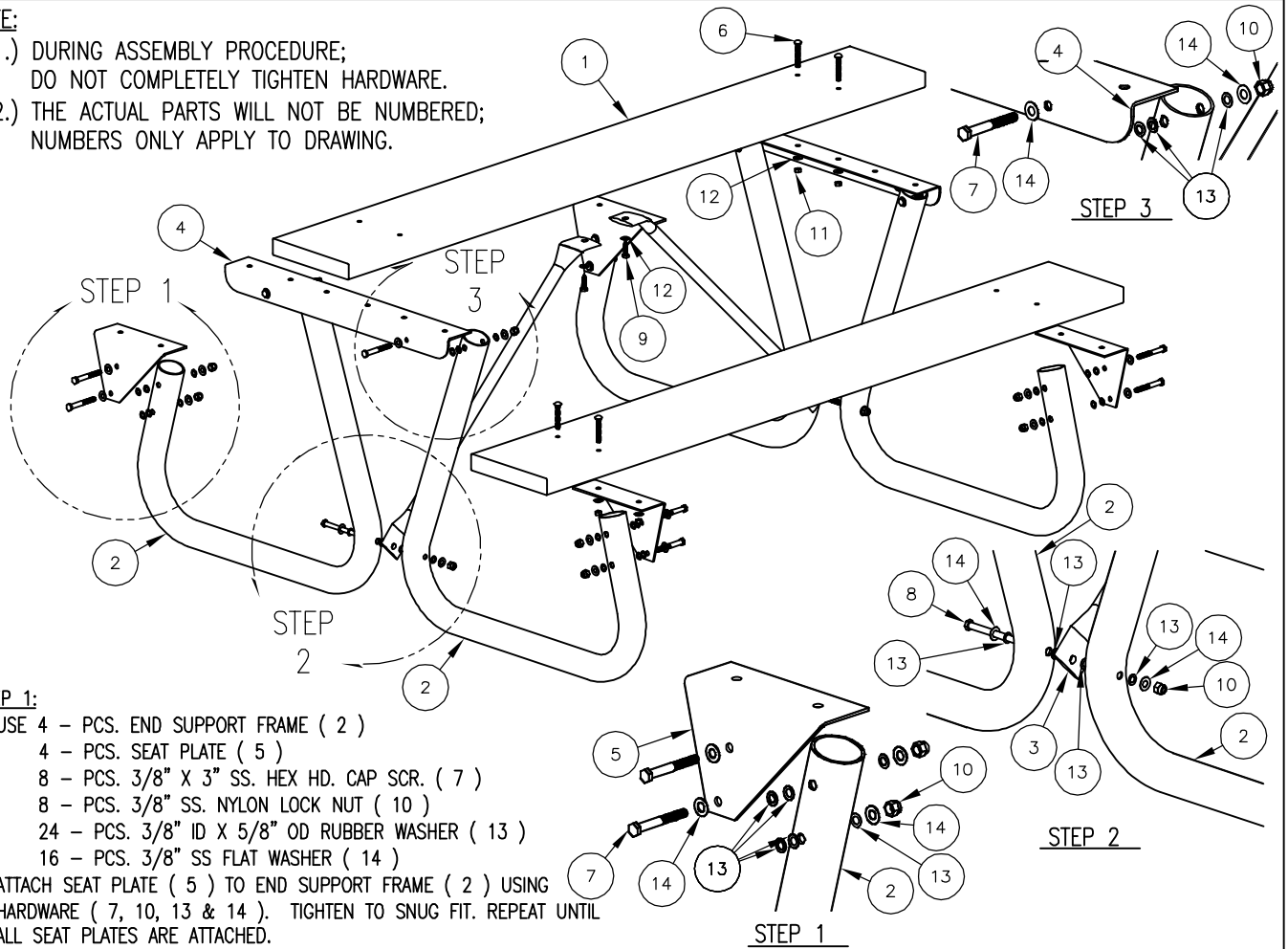

**STEP 1:**

- USE 4 - PCS. END SUPPORT FRAME ( 2 )
  - 4 - PCS. SEAT PLATE ( 5 )
  - 8 - PCS. 3/8" X 3" SS. HEX HD. CAP SCR. ( 7 )
  - 8 - PCS. 3/8" SS. NYLON LOCK NUT ( 10 )
  - 24 - PCS. 3/8" ID X 5/8" OD RUBBER WASHER ( 13 )
  - 16 - PCS. 3/8" SS FLAT WASHER ( 14 )
- ATTACH SEAT PLATE ( 5 ) TO END SUPPORT FRAME ( 2 ) USING HARDWARE ( 7, 10, 13 & 14 ). TIGHTEN TO SNUG FIT. REPEAT UNTIL ALL SEAT PLATES ARE ATTACHED.

**STEP 2:**

- USE 2 - PCS. DIAGONAL BRACE ( 3 )
  - 2 - PCS. 3/8" X 5 1/2" SS. HEX HD. CAP SCR. ( 8 )
  - 2 - PCS. 3/8" SS. NYLON LOCK NUT ( 10 )
  - 8 - PCS. 3/8" ID X 5/8" OD RUBBER WASHER ( 13 )
  - 4 - PCS. 3/8" SS FLAT WASHER ( 14 )
- ATTACH DIAGONAL BRACE ( 3 ) TO STEP 1 ASSEMBLY USING HARDWARE ( 8, 10, 13 & 14 ). TIGHTEN TO SNUG FIT.

**STEP 3:**

- USE 2 - PCS. TOP ANGLE ( 4 )
  - 4 - PCS. 3/8" X 3" SS. HEX HD. CAP SCR. ( 7 )
  - 4 - PCS. 3/8" SS. NYLON LOCK NUT ( 10 )
  - 12 - PCS. 3/8" ID X 5/8" OD RUBBER WASHER ( 13 )
  - 8 - PCS. 3/8" SS FLAT WASHER ( 14 )
- ATTACH TOP ANGLE ( 4 ) TO STEP 2 ASSEMBLY USING HARDWARE ( 7, 10, 13 & 14 ). TIGHTEN TO SNUG FIT.

**STEP 4:**

- USE 5 - PCS. 2" X 10" X 71" WOOD PLANK ( 1 )
  - 20 - PCS. 5/16" X 2 1/4" SS. CGE. BOLT ( 6 )
  - 20 - PCS. 5/16" SS. HEX NUT ( 11 )
  - 20 - PCS. 5/16" SS. FLAT WASHER ( 12 )
- ATTACH 2" X 10" X 71" WOOD PLANK ( 1 ) TO STEP 3 ASSEMBLY USING HARDWARE ( 6, 11, & 12 ). TIGHTEN TO SNUG FIT. REPEAT UNTIL ALL SLATS ARE ATTACHED.

**STEP 5:**

- USE 2 - PCS. 5/16" X 1 1/4" SS. HEX HD. LAG SCR. ( 9 )
  - 2 - PCS. 5/16" SS. FLAT WASHER ( 12 )
- SQUARE STEP 4 ASSEMBLY THEN ATTACH PIPE BRACE ( 3 ) TO CENTER PLANK USING HARDWARE ( 9 & 12 ). ( THERE ARE NO PILOT HOLES FOR LAG SCREWS )

**STEP 6:**

UPON COMPLETION OF TABLE ASSEMBLY TIGHTEN ALL HARDWARE.

ITEM	QTY	PART NO	DESCRIPTION
1	5	0-71-60-01	2" X 10" X 71" WOOD SLAT
2	4	0-72-00-02	END SUPPORT FRAME
3	2	0-72-00-03	DIAGONAL BRACE
4	2	0-72-00-04	TOP ANGLE
5	4	0-72-00-05	SEAT PLATE
6	20	1-11-062	5/16" X 2 1/4" SS CGE BOLT
7	12	1-12-002	3/8" X 3" SS HEX HD CAP SCR
8	2	1-12-039	3/8" X 5 1/2" SS HEX HD CAP SCR
9	2	1-13-001	5/16" X 1 1/4" SS HEX HD LAG SCR
10	14	1-20-007	3/8" SS NYLON LOCKNUT
11	20	1-21-015	5/16" SS HEX NUT
12	22	1-22-017	5/16" SS FLAT WASHER
13	44	1-22-018	3/8" ID X 5/8" OD RUBBER WASHER
14	28	1-22-024	3/8" SS FLAT WASHER

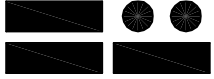
 <b>DuMor, inc.</b> P.O. Box 142 Mifflintown, PA 17059-0142	SCALE :	NONE	TITLE : <b>PICNIC TABLE ASSEMBLY</b>	
	DATE DRAWN :	3/22/94		
	DRAWN BY :	AH		
	DATE REV. :	10/4/06		
REV. :	F	DRAWING NUMBER	72 SERIES	SHEET 2 OF 2
REV. BY :	AWH			