

WOOD OPTIONS

- CLEAR ALL HEART REDWOOD S4S EE
- 'C' & BTR. DOUGLAS FIR KD S4S EE
- OTHER _____

NOTES

- 1.) ALL STL. MEMBERS COATED W/ ZINC RICH EPOXY THEN FINISHED W/ POLYESTER POWDER COATING.
- 2.) ALL WOOD MEMBERS TREATED W/ CLEAR PRESERVATIVE.
- 3.) 1/2" X 3 3/4" EXPANSION ANCHOR BOLTS FOR OPTIONS S-2 AND S-4.
- 4.) USE 3/8" X 2" S.STL. BUTTON SOCKET HEAD LAG SCREWS FOR 3" X 4" & 4" X 4" SLATS. USE 3/8" X 1 1/2" S.STL. HEX HD LAG SCREWS FOR 2" X 4" SLATS.

W/ 2 SEATS

- 76-22 (2" x 4")
- 76-32 (3" x 4")
- 76-42 (4" x 4")

DuMor, inc.
P.O. Box 142 Mifflintown, PA 17059-0142

SCALE : NONE
DATE DRAWN : 1/8/00
DRAWN BY : JSB
DATE REV. : 02/11/09
REV. BY : ESS

TITLE : PEDESTAL TABLE
REV. F
DRAWING NUMBER 76 SERIES-2
SHEET 1 OF 2

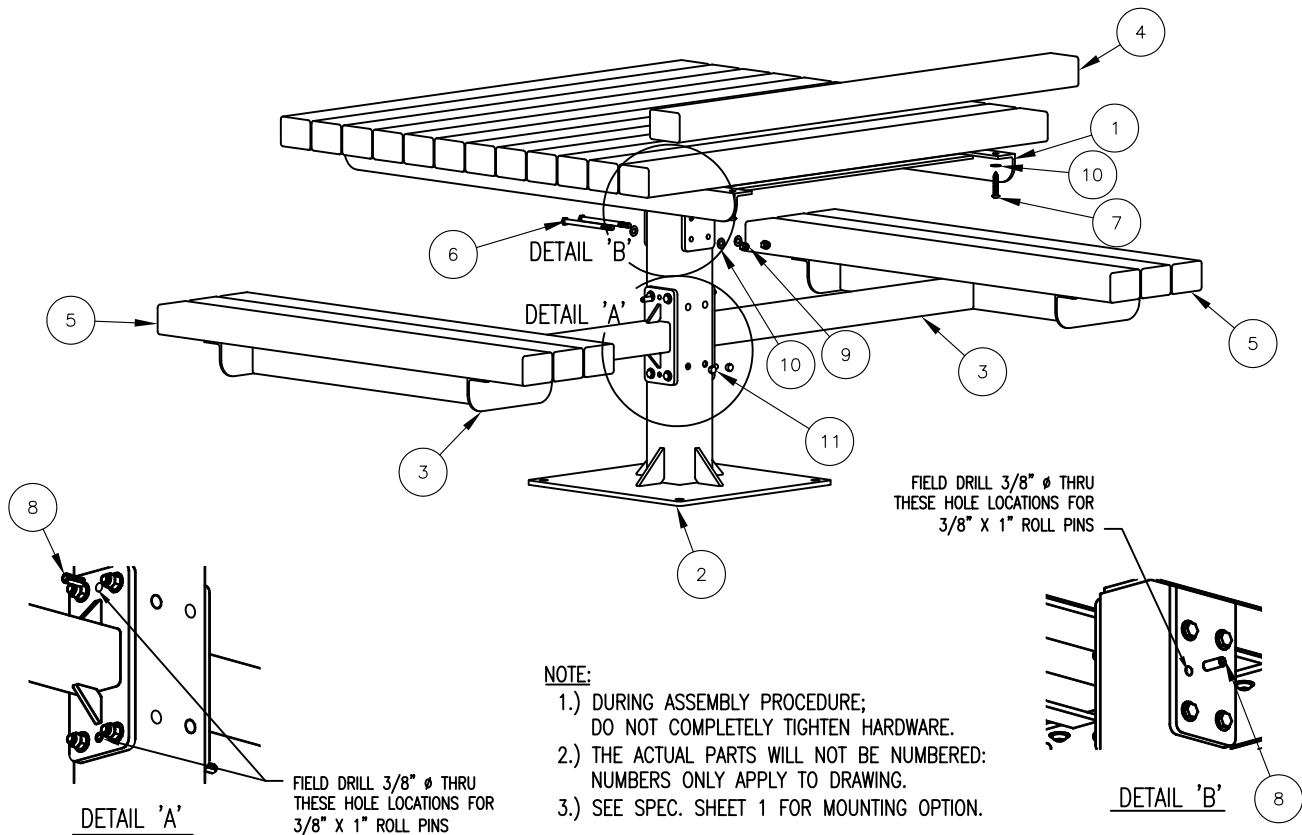

NOTE:

- 1.) DURING ASSEMBLY PROCEDURE; DO NOT COMPLETELY TIGHTEN HARDWARE.
- 2.) THE ACTUAL PARTS WILL NOT BE NUMBERED: NUMBERS ONLY APPLY TO DRAWING.
- 3.) SEE SPEC. SHEET 1 FOR MOUNTING OPTION.

STEP 1:

- USE 1 - PC. CTR. POST FOR SURFACE MOUNT, (2)
 - 1 - PC. TABLE TOP FRAME (1)
 - 4 - PCS. 3/8" X 5 1/2" SS. HEX HD. CAP SCR. (6)
 - 4 - PCS. 3/8" SS. NYLON LOCK NUT (9)
 - 8 - PCS. 3/8" SS. FLAT WASHER (10)
- ATTACH TABLE TOP FRAME (1) TO CTR. POST FOR SURFACE MOUNT, (2) USING HARDWARE (6, 9, & 10). TIGHTEN TO SNUG FIT.

STEP 2:

- USE 2 - PCS. SEAT SUPPORT ARM W/ 8" PLATE (3)
 - 4 - PCS. 3/8" X 5 1/2" SS. HEX HD. CAP SCR. (6)
 - 4 - PCS. 3/8" SS. NYLON LOCK NUT (9)
 - 8 - PCS. 3/8" SS. FLAT WASHER (10)
- ATTACH SEAT SUPPORT ARM W/ 8" PLATE (3) TO STEP 1 ASSEMBLY USING HARDWARE (6, 9, & 10). TIGHTEN TO SNUG FIT.

STEP 3:

- USE 13 - PCS. 3" X 4" X 47" WOOD TABLE SLAT (4)
 - 6 - PCS. 3" X 4" X 43" WOOD SEAT SLAT (5)
 - 38 - PCS. 3/8" X 2" SS. BTN. SKT. HD. LAG SCR. (7)
 - 38 - PCS. 3/8" SS. FLAT WASHER (10)
- ATTACH 3" X 4" X 47" TABLE SLATS (4) AND 3" X 4" X 43" SEAT SLATS (5) TO STEP 2 ASSEMBLY USING HARDWARE (7 & 10). TIGHTEN TO SNUG FIT. REPEAT UNTIL ALL SLATS ARE ATTACHED.

STEP 4:

- USE 8 - PCS. BLACK PLASTIC PLUG (11)
- INSERT BLACK PLASTIC PLUG INTO REMAINING HOLES.

STEP 5:

- UPON COMPLETION OF TABLE ASSEMBLY SQUARE ALL COMPONENTS THEN TIGHTEN ALL HARDWARE.

STEP 6:

- MOUNT AND ANCHOR AS SPECIFIED.

STEP 7:

- USE 6 - PCS. 3/8" X 1" S.STL. ROLL PIN (8)
- BE SURE SEAT AND TABLE TOP ARE LEVEL. FIELD DRILL CTR POST FOR SURFACE MOUNT (2) WITH 3/8" HOLE AT SEAT SUPPORT ARM W/ 8" PLATE (3) AND TABLE TOP FRAME (1) OPEN HOLE LOCATIONS. SEE DETAILS 'A' AND 'B'. DRIVE IN 3/8" X 1" ROLL PIN (8).

ITEM	QTY	PART NO	DESCRIPTION
1	1	0-6991-04	STL TABLE TOP FRAME
2	1	0-76-00-03/S-2	CTR POST FOR SURFACE MOUNT
3	2	0-76-00-05	SEAT SUPPORT ARM W/8" PLATE
4	13	0-76-30-01	3" X 4" X 47" WOOD SLAT
5	6	0-76-30-02	3" X 4" X 43" WOOD SLAT
6	8	1-12-039	3/8" X 5 1/2" SS HEX HD CAP SCR
7	38	1-13-016	3/8" X 2" SS BTN SKT HD LAG SCR
8	6	1-14-003	3/8" X 1" S.STL. ROLL PIN
9	8	1-20-007	3/8" SS NYLON LOCKNUT
10	54	1-22-024	3/8" SS FLAT WASHER
11	8	5-48-059	BLACK PLASTIC PLUG

DuMor, inc.
P.O. Box 142 Mifflintown, PA 17059-0142

SCALE : NONE
DATE DRAWN : 1/8/00
DRAWN BY : JSB
DATE REV. : 02/11/09
REV. BY : ESS

TITLE : PEDESTAL TABLE ASSEMBLY

REV. F	DRAWING NUMBER 76 SERIES-2	SHEET 2 OF 2
--------	----------------------------	--------------