

SLAT OPTIONS

- "CEDAR" RECYCLED PLASTIC
- "GREY" RECYCLED PLASTIC
- "REDWOOD" RECYCLED PLASTIC
- "WALNUT" RECYCLED PLASTIC
- OTHER _____

NOTES

- 1.) 1/2" X 3 3/4" EXPANSION ANCHORS AND 2" PIPE CLAMPS PROVIDED (4 - PCS)

FINISH OPTIONS:

- ALL STL. MEMBERS COATED W/ ZINC RICH EPOXY THEN FINISHED W/ POLYESTER POWDER COATING.
- HOT DIP GALV. AFTER FABRICATION.

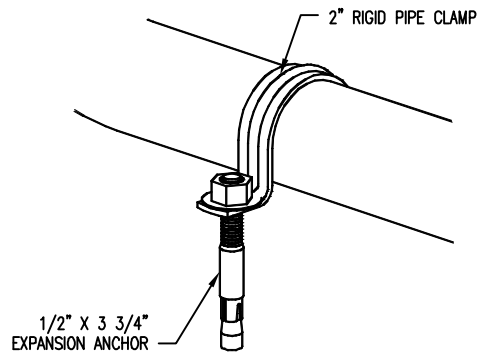

ANCHORING DETAIL



DuMor, inc.
P.O. Box 142 Mifflintown, PA 17059-0142

SCALE : NONE
 DATE DRAWN : 3/22/94
 DRAWN BY : CDC
 DATE REV. : 10/27/11
 REV. BY : RDH

TITLE : PICNIC TABLE

REV. 1	DRAWING NUMBER 77-68-1 PL	SHEET 1 OF 2
--------	---------------------------	--------------

NOTE:

- 1.) DURING ASSEMBLY PROCEDURE;
DO NOT COMPLETELY TIGHTEN HARDWARE;
- 2.) THE ACTUAL PARTS WILL NOT BE NUMBERED;
NUMBER ONLY APPLY TO THE DRAWING.
- 3.) SEE SPEC SHEET 1 FOR MOUNTING DETAILS.

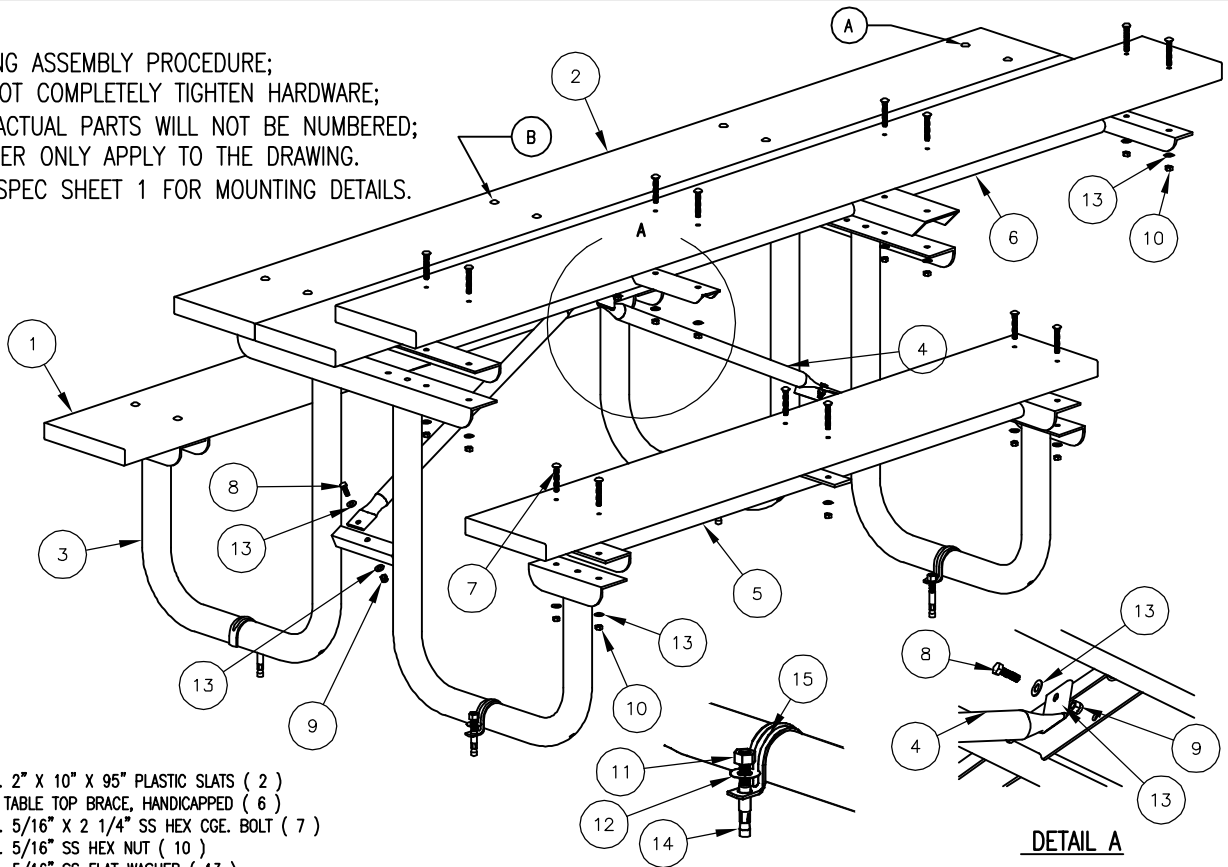

STEP 1:

USE 3 - PCS. 2" X 10" X 95" PLASTIC SLATS (2)
 1 - PC. TABLE TOP BRACE, HANDICAPPED (6)
 12 - PCS. 5/16" X 2 1/4" SS HEX CGE. BOLT (7)
 12 - PCS. 5/16" SS HEX NUT (10)
 12 - PCS. 5/16" SS FLAT WASHER (13)
 ATTACH 2" X 10" X 95" PLASTIC SLATS (2) AT LOCATION
 (A & B) OF TABLE TOP BRACE, HANDICAPPED (6) USING
 HARDWARE (7, 10 & 13). TIGHTEN TO SNUG FIT. REPEAT UNTIL
 ALL SLATS ARE ATTACHED.

STEP 2:

USE 2 - PCS. END SUPPORT FRAME (3)
 12 - PCS. 5/16" X 2 1/4" SS HEX CGE. BOLT (7)
 12 - PCS. 5/16" SS HEX NUT (10)
 12 - PCS. 5/16" SS FLAT WASHER (13)
 ATTACH STEP 1 ASSEMBLY TO END SUPPORT FRAMES (3)
 USING HARDWARE (7, 10 & 13). TIGHTEN TO SNUG FIT.

STEP 3:

USE 2 - PCS. 2" X 10" X 65" PLASTIC SLATS (1)
 2 - PCS. 6' SEAT BRACE (5)
 4 - PCS. 5/16" X 2 1/4" SS HEX CGE. BOLT (7)
 4 - PCS. 5/16" SS HEX NUT (10)
 4 - PCS. 5/16" SS FLAT WASHER (13)
 ATTACH 2" X 10" X 65" PLASTIC SLATS (1) TO CENTER
 OF 6' SEAT BRACE (5) USING HARDWARE (7, 10 & 13).
 TIGHTEN TO SNUG FIT.

STEP 4:

USE 8 - PCS. 5/16" X 2 1/4" SS HEX CGE. BOLT (7)
 8 - PCS. 5/16" SS HEX NUT (10)
 8 - PCS. 5/16" SS FLAT WASHER (13)
 ATTACH STEP 3 ASSEMBLY TO STEP 2 ASSEMBLY SUPPORT FRAME
 (3) USING HARDWARE (7, 10 & 13). TIGHTEN TO SNUG FIT.

STEP 5:

USE 2 - PCS. DIAGONAL BRACE FOR 6' TABLE (4)
 4 - PCS. 5/16" X 1" SS HEX HD CAP SCREW (8)
 4 - PCS. 5/16" SS NYLON LOCK NUT (9)
 8 - PCS. 5/16" SS FLAT WASHER (13)
 ATTACH DIAGONAL BRACE FOR 6' TABLE (4) TO STEP 4
 ASSEMBLY USING HARDWARE (8, 9 & 13) AS SHOWN IN
 DETAIL A. TIGHTEN TO SNUG FIT.

STEP 6:

UPON COMPLETION OF TABLE ASSEMBLY TIGHTEN ALL HARDWARE.

STEP 7:

4 - PCS. 1/2" SS. HEX NUT (11)
 4 - PCS. 1/2" SS. FLAT WASHER (12)
 4 - PCS. 1/2" X 3 3/4" EXPANSION ANCHORS (14)
 4 - PCS. 2" RIGID PIPE CLAMP (15)
 PLACE TABLE IN SITE LOCATION DESIRED. PLACE 2" RIGID
 PIPE CLAMP IN CENTER OF TABLE LEGS. MARK HOLES
 AND MOVE 2" RIGID PIPE CLAMPS. DRILL 1/2" DIA HOLE
 IN CONCRETE AT MARKED HOLE LOCATIONS APPROX. 3 1/2" DEEP.
 BLOW OUT DUST IN DRILLED HOLES. PLACE 1/2" X 3 3/4"
 EXPANSION ANCHORS IN HOLES. PLACE NUT TO FLUSH
 WITH END AND DRIVE INTO GROUND. REMOVE NUT AND PLACE
 2" RIGID PIPE CLAMPS OVER TABLE LEGS AND ON 1/2" X 3 3/4"
 EXPANSION ANCHORS. ATTACH WASHER AND NUT AND TIGHTEN.

ITEM	QTY	PART NO	DESCRIPTION
1	2	0-71-68-1PL-1	2" X 10" X 65" PLASTIC SLAT
2	3	0-71-68-1PL-2	2" X 10" X 95" PLASTIC SLAT
3	2	0-77-00-01	END SUPPORT FRAME
4	2	0-77-60-02	DIAGONAL BRACE FOR 6' TABLE
5	2	0-77-60-14	6' SEAT BRACE
6	1	0-77-68-1-15	TABLE TOP BRACE, HANDICAPPED
7	36	1-11-062	5/16" X 2 1/4" SS CGE BOLT
8	4	1-12-061	5/16" X 1" SS HEX HD CAP SCR
9	4	1-20-016	5/16" SS NYLON LOCKNUT
10	36	1-21-015	5/16" SS HEX NUT
11	4	1-21-016	1/2" SS HEX NUT
12	4	1-22-015	1/2" SS FLAT WASHER
13	44	1-22-017	5/16" SS FLAT WASHER
14	4	1-17-003	1/2" X 3 3/4" SS EXPANSION ANCHOR
15	4	5-48-492	2" RIGID PIPE CLAMP, 9/16" DIA HOLE, PLTD

DuMor, inc.
 P.O. Box 142 Mifflintown, PA 17059-0142

SCALE : NONE
 DATE DRAWN : 3/22/94
 DRAWN BY : CDC
 DATE REV. : 10/27/11
 REV. BY : RDH

TITLE : PICNIC TABLE ASSEMBLY
 REV. 1
 DRAWING NUMBER 77-68-1 PL
 SHEET 2 OF 2