 <p>DuMor, inc. P.O. Box 142 Mifflintown, PA 17059-0142</p>	SCALE :	NONE	TITLE :		GAME TABLE	
	DATE DRAWN :	12/11/06	DRAWN BY :	JSB	REV. :	DRAWING NUMBER
	DATE REV. :	01/13/11	REV. :	E	78-34PL	
	REV. BY :	RDH			SHEET	1 OF 2

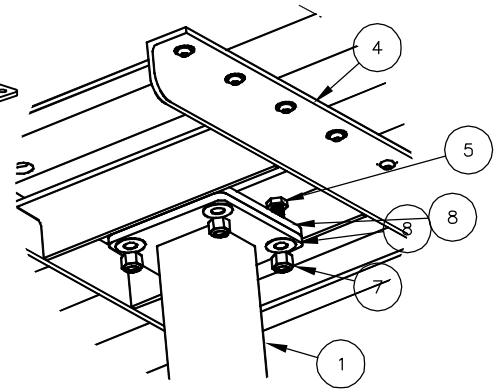
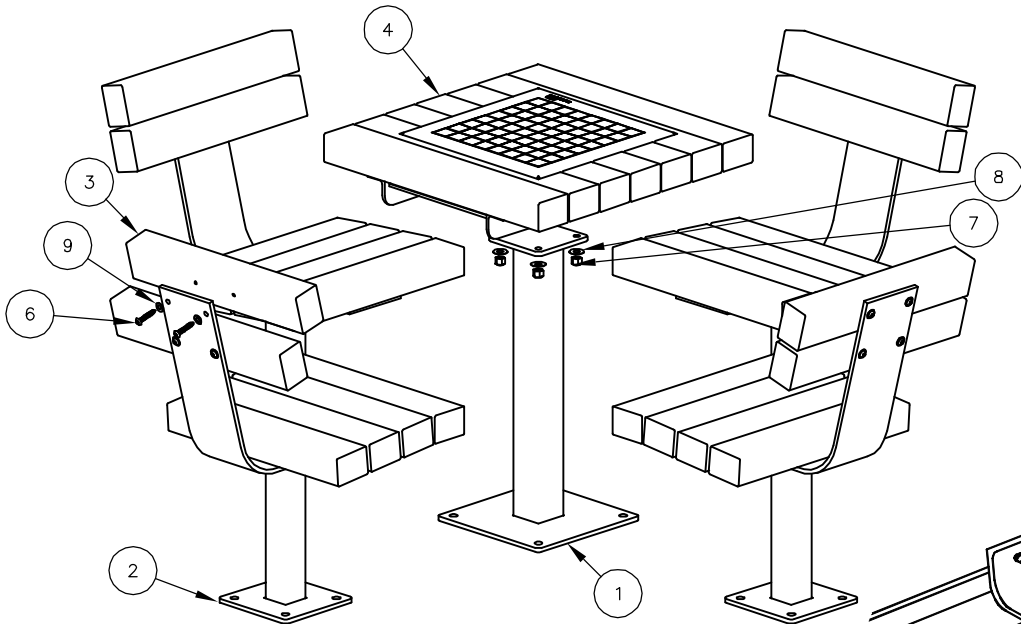

DETAIL A

NOTE:

- 1.) DURING ASSEMBLY PROCEDURE;
DO NOT COMPLETELY TIGHTEN HARDWARE.
- 2.) THE ACTUAL PARTS WILL NOT BE NUMBERED;
NUMBERS ONLY APPLY TO DRAWING.
- 3.) SEE SPEC. SHEET 1 FOR MOUNTING OPTION.
- 4.) TABLE TOP SHIPPED FULLY ASSEMBLED.

STEP 1:

- USE 4 - PCS. SEAT SUPPORT FOR SURFACE MOUNT (2)
- 24 - PCS. 3" X 4" X 20" PLASTIC SEAT SLAT (3)
- 48 - PCS. 3/8" X 2" SS. BTN. SKT. HD. LAG SCR. (6)
- 48 - PCS. 3/8" SS. FLAT WASHER (9)

ATTACH 3" X 4" X 20" PLASTIC SEAT SLATS (3) TO SEAT SUPPORT FOR SURFACE MOUNT (2) USING HARDWARE (6 & 9). TIGHTEN TO SNUG FIT. REPEAT UNTIL ALL SLATS ARE ATTACHED.

STEP 2:

- USE 1 PC. TABLE SUPPORT FOR SURFACE MOUNT (1)
- 1 PC. TABLE TOP ASSEMBLY W/ CHECKERBOARD (4)
- 4 PCS. 1/2" X 1 1/2" SS HEX HD CAP SCR (5)
- 4 PCS. 1/2" SS NYLON LOCK NUT (7)
- 8 PCS. 1/2" SS FLAT WASHER (8)

ATTACH TABLE TOP ASSEMBLY W/ CHECKERBOARD (4) TO TABLE SUPPORT FOR SURFACE MOUNT (1) USING HARDWARE (5, 7 & 8). TIGHTEN TO SNUG FIT.

STEP 3:

UPON COMPLETION OF SEAT & TABLE ASSEMBLY SQUARE ALL COMPONENTS THEN TIGHTEN ALL HARDWARE.

STEP 4:

MOUNT AND ANCHOR AS SPECIFIED.

ITEM	QTY	PART NO	DESCRIPTION
1	1	0-78-00-01/S-2	TABLE SUPPORT FOR SURFACE MOUNT
2	4	0-78-00-02/S-2	SEAT SUPPORT FOR SURFACE MOUNT
3	24	0-78-00PL-04	3" X 4" X 20" PL SEAT SLAT
4	1	0-78-30PL	TABLE TOP ASSEMBLY W/ CKRBD
5	4	1-12-004	1/2" X 1 1/2" SS HEX HD CAP SCR
6	48	1-13-016	3/8" X 2" SS BTN SKT HD LAG SCR
7	4	1-20-015	1/2" SS NYLON LOCKNUT
8	8	1-22-015	1/2" SS FLAT WASHER
9	48	1-22-024	3/8" SS FLAT WASHER

DuMor, inc.
P.O. Box 142 Mifflintown, PA 17059-0142

SCALE : NONE
DATE DRAWN : 12/11/06
DRAWN BY : JSB
DATE REV. : 01/13/11
REV. BY : RDH

TITLE : GAME TABLE ASSEMBLY
REV. E
DRAWING NUMBER 78-34PL
SHEET 2 OF 2