

S-2 SURFACE

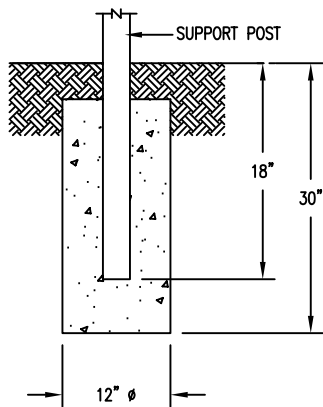

S-1 EMBEDMENT

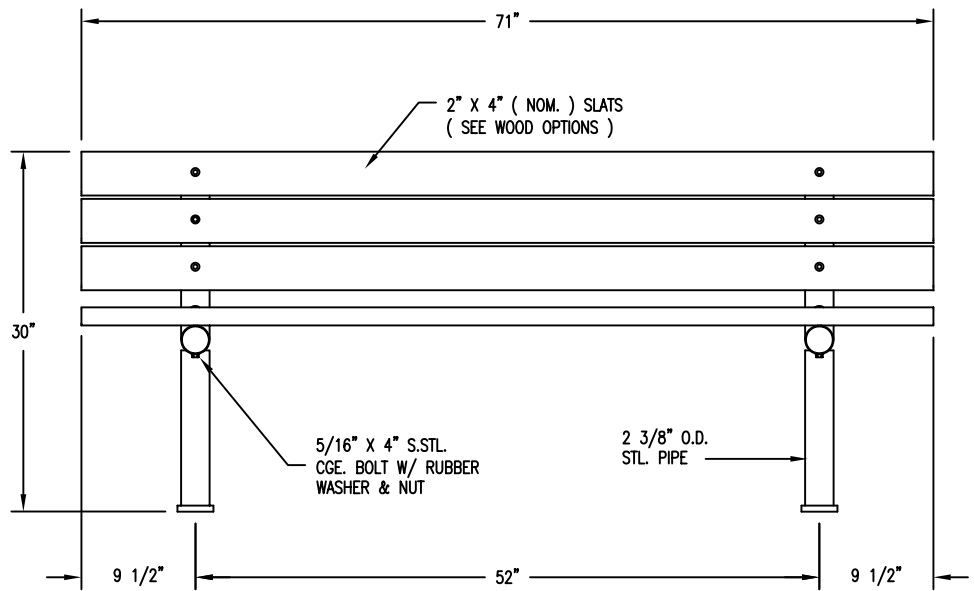
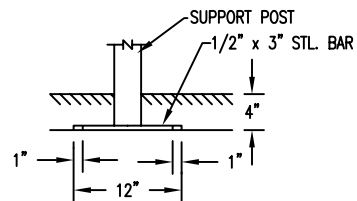
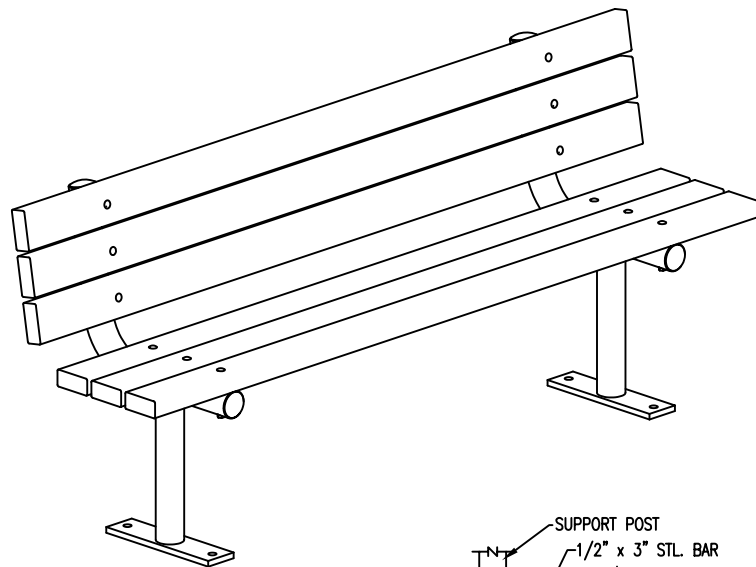

S-4 SUB FLOOR

NOTES

- 1.) ALL STL. MEMBERS COATED W/ ZINC RICH EPOXY THEN FINISHED W/ POLYESTER POWDER COATING.
- 2.) ALL WOOD MEMBERS TREATED W/ CLEAR PRESERVATIVE.
- 3.) 1/2" X 3 3/4" EXPANSION ANCHOR BOLTS PROVIDED FOR S-2 & S-4 OPTIONS.

WOOD OPTIONS

- CLEAR ALL HEART REDWOOD S4S EE
- 'C' & BTR. DOUGLAS FIR KD S4S EE
- OTHER _____

DuMor, inc.
 P.O. Box 142 Mifflintown, PA 17059-0142

SCALE : NONE
 DATE DRAWN : 7/31/95
 DRAWN BY : AH
 DATE REV. : 12/15/08
 REV. BY : ESS

TITLE : BENCH
 REV. D
 DRAWING NUMBER 79-60
 SHEET 1 OF 2

SURFACE MOUNT
OPTION SHOWN

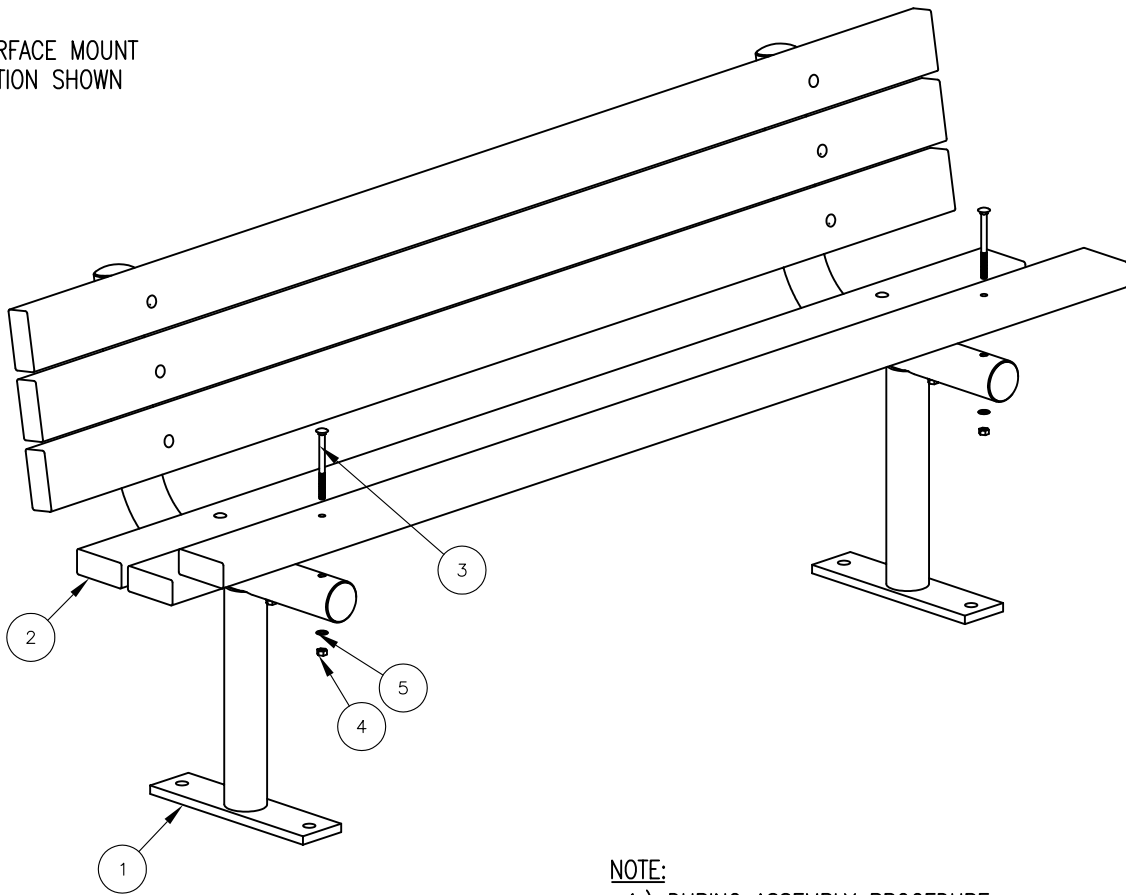

NOTE:

- 1.) DURING ASSEMBLY PROCEDURE;
DO NOT COMPLETELY TIGHTEN HARDWARE.
- 2.) THE ACTUAL PARTS WILL NOT BE NUMBERED:
NUMBERS ONLY APPLY TO DRAWING.
- 3.) SEE SPEC. SHEET 1 FOR MOUNTING OPTION.

STEP 1:

USE 2 - PCS. SUPPORT FOR SURFACE MOUNT (1)
 6 - PCS. 2" X 4" X 71" WOOD SLAT (2)
 12 - PCS. 5/16" X 4" SS. CGE. BOLT (3)
 12 - PCS. 5/16" SS. HEX NUT (4)
 12 - PCS. 3/8" I.D. X 5/8" O.D. RUBBER WASHER (5)
 ATTACH SLATS (2) TO SUPPORT FOR SURFACE MOUNT (1)
 USING HARDWARE (3, 4 & 5). TIGHTEN TO SNUG FIT.
 REPEAT UNTIL ALL SLATS ARE ATTACHED.

STEP 2:

UPON COMPLETION OF BENCH ASSEMBLY SQUARE
 COMPONENTS THEN TIGHTEN ALL HARDWARE.

STEP 3:

ANCHOR ACCORDING TO SUPPORT OPTION USED.

ITEM	QTY	PART NO	DESCRIPTION
1	2	0-79-00-02/S-2	SUPPORT FOR SURFACE MOUNT
2	6	0-79-60-01	2" X 4" X 6' WOOD SLAT
3	12	1-11-001	5/16" X 4" SS CGE BOLT
4	12	1-21-015	5/16" SS HEX NUT
5	12	1-22-018	3/8" ID X 5/8" OD RUBBER WASHER



DuMor, inc.
 P.O. Box 142 Mifflintown, PA 17059-0142

SCALE : NONE
 DATE DRAWN : 7/31/95
 DRAWN BY : AH
 DATE REV. : 12/15/08
 REV. BY : ESS

TITLE : BENCH ASSEMBLY

REV. D DRAWING NUMBER 79-60

SHEET 2 OF 2