

S-2 SURFACE

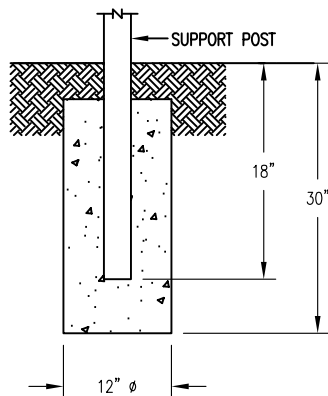

S-1 EMBEDMENT

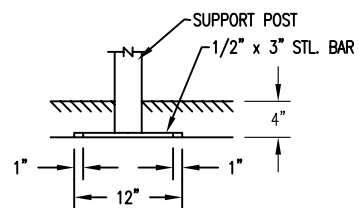
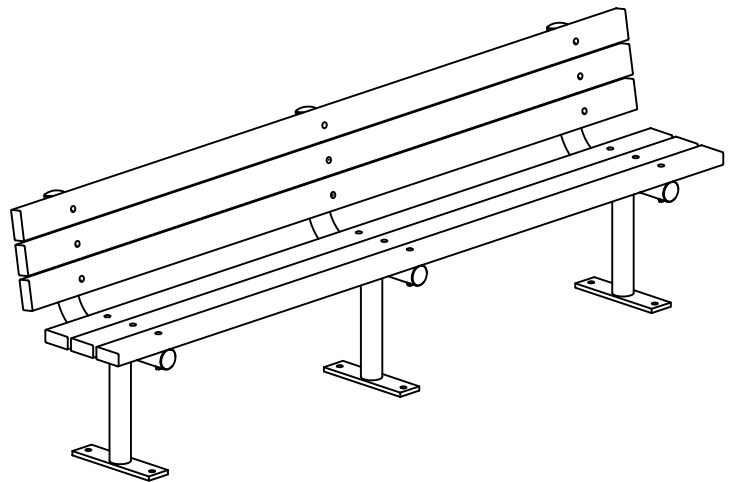

S-4 SUB FLOOR

**NOTES**

- 1.) ALL STL. MEMBERS COATED W/ ZINC RICH EPOXY THEN FINISHED W/ POLYESTER POWDER COATING.
- 2.) ALL WOOD MEMBERS TREATED W/ CLEAR PRESERVATIVE.
- 3.) 1/2" X 3 3/4" EXPANSION ANCHOR BOLTS PROVIDED FOR S-2 & S-4 OPTIONS.

**WOOD OPTIONS**

- CLEAR ALL HEART REDWOOD S4S EE
- 'C' & BTR. DOUGLAS FIR KD S4S EE
- OTHER \_\_\_\_\_

**DuMor, inc.**  
 P.O. Box 142 Mifflintown, PA 17059-0142

SCALE : NONE  
 DATE DRAWN : 11/11/99  
 DRAWN BY : JSB  
 DATE REV. : 12/15/08  
 REV. BY : ESS

TITLE : BENCH  
 REV. B  
 DRAWING NUMBER 79-80  
 SHEET 1 OF 2

SURFACE MOUNT  
OPTION SHOWN

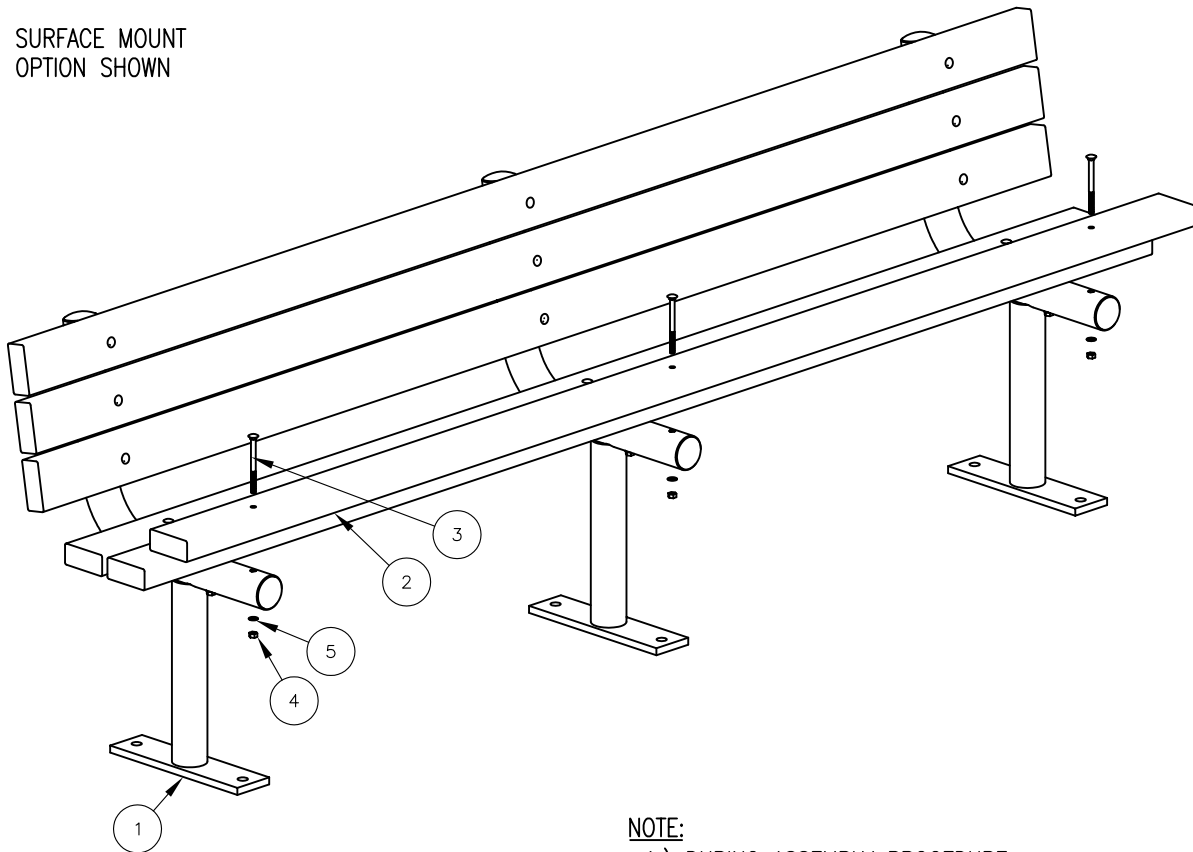

**NOTE:**

- 1.) DURING ASSEMBLY PROCEDURE;  
DO NOT COMPLETELY TIGHTEN HARDWARE.
- 2.) THE ACTUAL PARTS WILL NOT BE NUMBERED:  
NUMBERS ONLY APPLY TO DRAWING.
- 3.) SEE SPEC. SHEET 1 FOR MOUNTING OPTION.

**STEP 1:**

USE 3 - PCS. SUPPORT FOR SURFACE MOUNT ( 1 )  
 6 - PCS. 2" X 4" X 95" WOOD SLAT ( 2 )  
 18 - PCS. 5/16" X 4" SS. CGE. BOLT ( 3 )  
 18 - PCS. 5/16" SS. HEX NUT ( 4 )  
 18 - PCS. 3/8" I.D. X 5/8" O.D. RUBBER WASHER ( 5 )  
 ATTACH SLATS ( 2 ) TO SUPPORT FOR SURFACE MOUNT ( 1 )  
 USING HARDWARE ( 3, 4 & 5 ). TIGHTEN TO SNUG FIT.  
 REPEAT UNTIL SLATS ARE ATTACHED.

**STEP 2:**

UPON COMPLETION OF BENCH ASSEMBLY SQUARE  
 COMPONENTS THEN TIGHTEN ALL HARDWARE.

**STEP 3:**

ANCHOR ACCORDING TO SUPPORT OPTION USED.

ITEM	QTY	PART NO	DESCRIPTION
1	3	0-79-00-02/S-2	SUPPORT FOR SURFACE MOUNT
2	6	0-79-80-01	2" X 4" X 8" WOOD SLAT
3	18	1-11-001	5/16" X 4" SS CGE BOLT
4	18	1-21-015	5/16" SS HEX NUT
5	18	1-22-018	3/8" ID X 5/8" OD RUBBER WASHER

 <b>DuMor, inc.</b> P.O. Box 142 Mifflintown, PA 17059-0142	SCALE :	NONE		TITLE : <b>BENCH ASSEMBLY</b>		
	DATE DRAWN :	11/11/99				
	DRAWN BY :	JSB		REV. <b>B</b>	DRAWING NUMBER <b>79-80</b>	SHEET <b>2 OF 2</b>
	DATE REV. :	12/15/08				
	REV. BY :	ESS				