

NOTES:

- 1.) ALL STL. MEMBERS GALVANIZED.
WELDS COATED WITH ZINC-RICH FINISH.
- 2.) 1/2" X 5 1/2" EXPANSION ANCHOR BOLTS PROVIDED.

LENGTH OPTIONS

- 5' RACK
- 10' RACK



DuMor, inc.
P.O. Box 142 Mifflintown, PA 17059-0142

SCALE : NONE
DATE DRAWN : 3/22/94
DRAWN BY : CDC
DATE REV. : 7/9/02
REV. BY : CDC

TITLE : SINGLE-SIDE ENTRY
BIKE RACK

REV.
C

DRAWING
NUMBER
81 SERIES

SHEET
1 OF 2

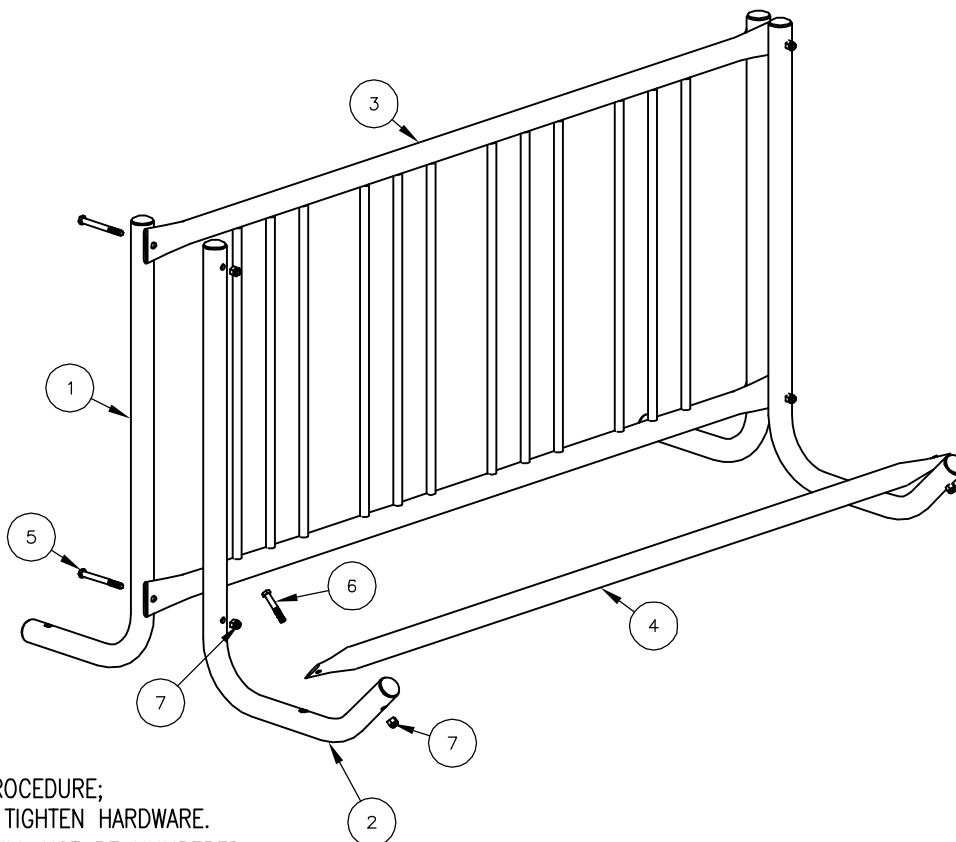

NOTE:

- 1.) DURING ASSEMBLY PROCEDURE;
DO NOT COMPLETELY TIGHTEN HARDWARE.
- 2.) THE ACTUAL PARTS WILL NOT BE NUMBERED;
NUMBERS ONLY APPLY TO DRAWING.

STEP 1:

- USE 1 - PC. 5' RACK ASSEMBLY (3)
 - 2 - PCS. "L" SUPPORT (1)
 - 2 - PCS. "J" SUPPORT (2)
 - 4 - PCS. 3/8" X 3 3/4" SS HEX HD CAP SCR. (5)
 - 4 - PCS. 3/8" SS NYLON LOCK NUT (7)
- ATTACH "L" SUPPORT (1) AND "J" SUPPORT TO 5' RACK ASSEMBLY (3) USING HARDWARE (5, & 7).
TIGHTEN TO SNUG FIT.

STEP 2:

- USE 1 - PC. 5' WHEEL STOP (4)
 - 2 - PCS. 3/8" X 2 1/4" SS HEX HD CAP SCR. (6)
 - 2 - PCS. 3/8" SS NYLON LOCK NUT (7)
- ATTACH 5' WHEEL STOP (4) TO STEP 1 ASSEMBLY USING
HARDWARE (6, & 7). TIGHTEN TO SNUG FIT.

STEP 3:

UPON COMPLETION OF BIKE RACK ASSEMBLY SQUARE ALL COMPONENTS THEN TIGHTEN ALL HARDWARE.

STEP 4:

MOUNT AND ANCHOR AS SPECIFIED.

ITEM	QTY	PART NO	DESCRIPTION
1	2	0-81-00-02	"L" SUPPORT
2	2	0-81-00-03	"J" SUPPORT
3	1	0-81-50-01	5' RACK ASSEMBLY
4	1	0-81-50-04	5' WHEEL STOP
5	4	1-12-080	3/8" X 3 3/4" SS HEX HD CAP SCR
6	2	1-12-086	3/8" X 2 1/4" SS HEX HD CAP SCR
7	6	1-20-007	3/8" SS NYLON LOCKNUT

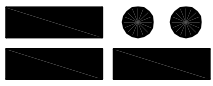
 DuMor, inc. P.O. Box 142 Mifflintown, PA 17059-0142	SCALE :	NONE	TITLE : SINGLE-SIDE ENTRY BIKE RACK ASSEMBLY	
	DATE DRAWN :	3/22/94		
	DRAWN BY :	CDC	REV. :	DRAWING NUMBER
	DATE REV. :	7/9/02	C	81 SERIES
	REV. BY :	CDC		SHEET 2 OF 2