

NOTES:

- 1.) ALL STL. MEMBERS GALVANIZED.  
WELDS COATED WITH ZINC-RICH FINISH.
- 2.) 1/2" X 5 1/2" EXPANSION ANCHOR BOLTS PROVIDED.

LENGTH OPTIONS

- 5' RACK
- 10' RACK



**DuMor, inc.**  
P.O. Box 142 Mifflintown, PA 17059-0142

SCALE : NONE

DATE DRAWN : 3/22/94

DRAWN BY : CDC

DATE REV. : 11/8/10

REV. BY : JSB

TITLE : DUAL-SIDE ENTRY BIKE RACK

REV. F

DRAWING NUMBER

82 SERIES

SHEET 1 OF 2

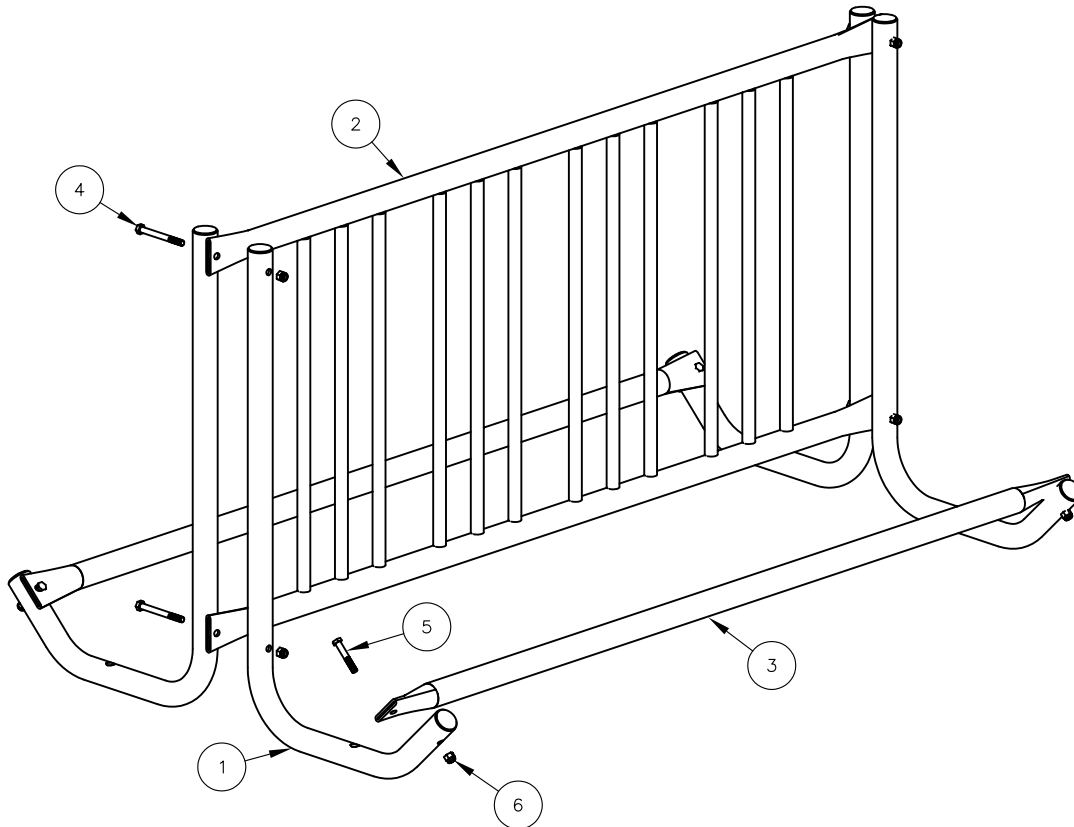

**NOTE:**

- 1.) DURING ASSEMBLY PROCEDURE;  
DO NOT COMPLETELY TIGHTEN HARDWARE.
- 2.) THE ACTUAL PARTS WILL NOT BE NUMBERED;  
NUMBERS ONLY APPLY TO DRAWING.

**STEP 1:**

- USE 1 – PC. 5' RACK ASSEMBLY ( 2 )  
 4 – PCS. "J" SUPPORT ( 1 )  
 4 – PCS. 3/8" X 3 3/4" SS HEX HD CAP SCR. ( 4 )  
 4 – PCS. 3/8" SS NYLON LOCK NUT ( 6 )  
 ATTACH "J" SUPPORTS ( 1 ) TO 5' RACK ASSEMBLY ( 2 )  
 USING HARDWARE ( 4, & 6 ). TIGHTEN TO SNUG FIT.

**STEP 2:**

- USE 2 – PCS. 5' WHEEL STOP ( 3 )  
 4 – PCS. 3/8" X 2 1/4" SS HEX HD CAP SCR. ( 5 )  
 4 – PCS. 3/8" SS NYLON LOCK NUT ( 6 )  
 ATTACH 5' WHEEL STOP ( 3 ) TO STEP 1 ASSEMBLY USING  
 HARDWARE ( 5, & 6 ). TIGHTEN TO SNUG FIT.

**STEP 3:**

UPON COMPLETION OF BIKE RACK ASSEMBLY SQUARE ALL  
 COMPONENTS THEN TIGHTEN ALL HARDWARE.

**STEP 4:**

MOUNT AND ANCHOR AS SPECIFIED.

ITEM	QTY	PART NO	DESCRIPTION
1	4	0-81-00-03	"J" SUPPORT
2	1	0-81-50-01	5' RACK ASSEMBLY
3	2	0-81-50-04	5' WHEEL STOP
4	4	1-12-080	3/8" X 3 3/4" SS HEX HD CAP SCR
5	4	1-12-086	3/8" X 2 1/4" SS HEX HD CAP SCR
6	8	1-20-007	3/8" SS NYLON LOCKNUT

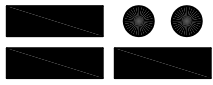
 <b>DuMor, inc.</b> P.O. Box 142 Mifflintown, PA 17059-0142	SCALE :	NONE	TITLE : DUAL-SIDE ENTRY BIKE RACK ASSEMBLY	
	DATE DRAWN :	3/22/94		
	DRAWN BY :	CDC	REV.	DRAWING NUMBER  82 SERIES
	DATE REV. :	11/8/10	F	
REV. BY :	JSB			