

NOTES:

- 1.) ALL STL. MEMBERS COATED W/ ZINC RICH EPOXY THEN FINISHED W/ POLYESTER POWDER COATING.
- 2.) 1/2" X 3 3/4" EXPANSION ANCHOR BOLTS PROVIDED.

SLAT OPTIONS

- "CEDAR" RECYCLED PLASTIC
- "GREEN" RECYCLED PLASTIC
- "GREY" RECYCLED PLASTIC
- "REDWOOD" RECYCLED PLASTIC
- "WALNUT" RECYCLED PLASTIC
- OTHER _____



DuMor, inc.
P.O. Box 142 Mifflintown, PA 17059-0142

SCALE : NONE
 DATE DRAWN : 1/10/02
 DRAWN BY : AWH
 DATE REV. : 12/03/09
 REV. BY : ESS

TITLE : BENCH		DRAWING NUMBER : 91-40PL	SHEET 1 OF 2
REV. : D			

NOTE:

- 1.) DURING ASSEMBLY PROCEDURE;
DO NOT COMPLETELY TIGHTEN HARDWARE.
- 2.) THE ACTUAL PARTS WILL NOT BE NUMBERED,
NUMBERS ONLY APPLY TO DRAWING.

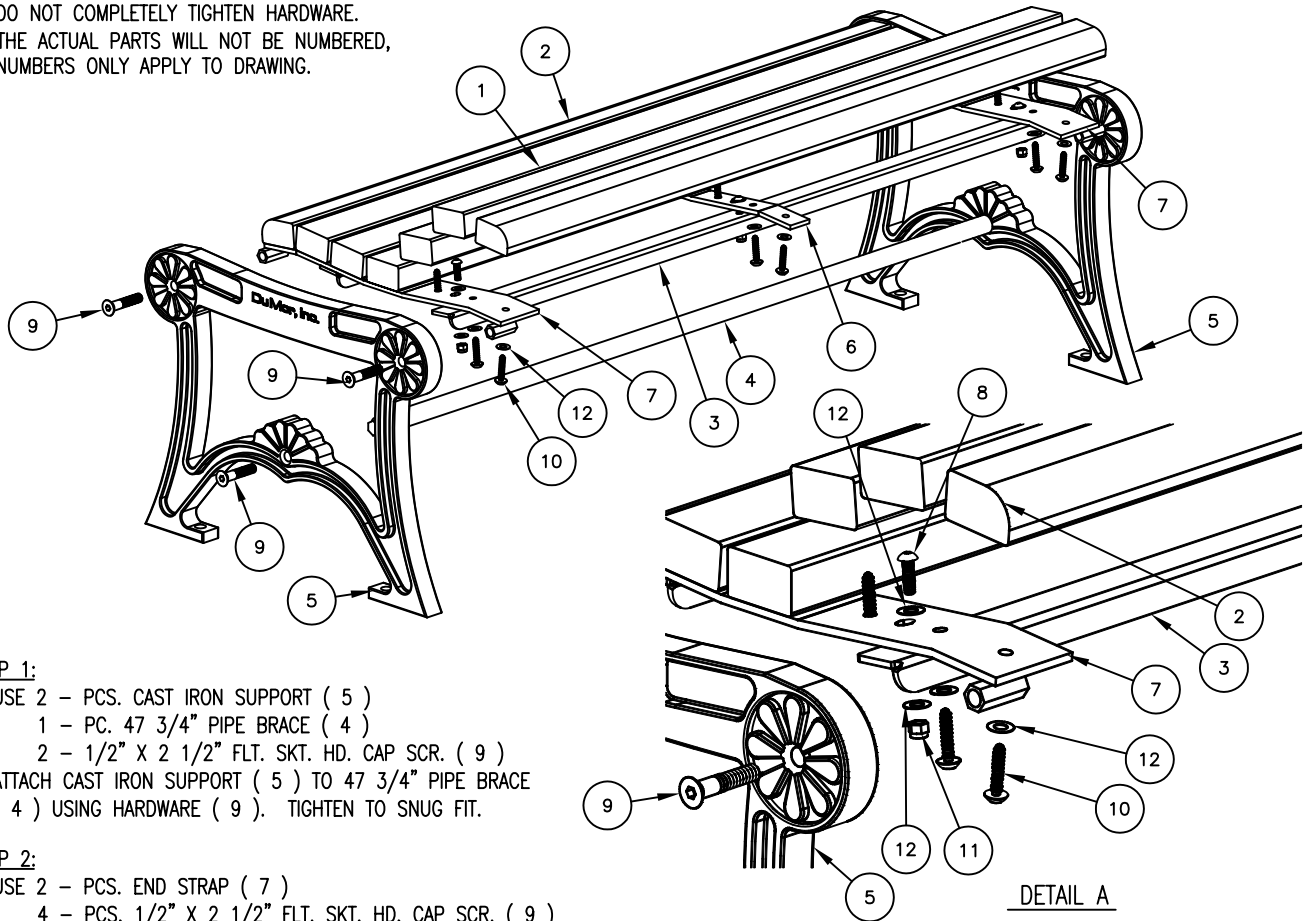

STEP 1:

- USE 2 - PCS. CAST IRON SUPPORT (5)
 - 1 - PC. 47 3/4" PIPE BRACE (4)
 - 2 - 1/2" X 2 1/2" FLT. SKT. HD. CAP SCR. (9)
- ATTACH CAST IRON SUPPORT (5) TO 47 3/4" PIPE BRACE (4) USING HARDWARE (9). TIGHTEN TO SNUG FIT.

STEP 2:

- USE 2 - PCS. END STRAP (7)
 - 4 - PCS. 1/2" X 2 1/2" FLT. SKT. HD. CAP SCR. (9)
- ATTACH END STRAP (7) TO STEP 1 ASSEMBLY USING HARDWARE (9). TIGHTEN TO SNUG FIT.

STEP 3:

- USE 2 - PCS. 47" SEAT TUBE BRACE (3)
 - 4 - PCS. 5/16" X 1" SS. BTN. SKT. HD. CAP (8)
 - 4 - PCS. 5/16" SS. NYLON LOCK NUT (11)
 - 4 - PCS. 5/16" SS. FLAT WASHER (12)
- ATTACH 47" SEAT TUBE BRACE (3) TO STEP 2 ASSEMBLY USING HARDWARE (8, 11, & 12). TIGHTEN TO SNUG FIT.

STEP 4:

- USE 1 - PCS. CENTER STRAP (6)
 - 2 - PCS. 5/16" X 1" SS. BTN. SKT. HD. CAP (8)
 - 2 - PCS. 5/16" SS. NYLON LOCK NUT (11)
 - 2 - PCS. 5/16" SS. FLAT WASHER (12)
- ATTACH CENTER STRAP (6) TO STEP 3 ASSEMBLY USING HARDWARE (8, 11, & 12). TIGHTEN TO SNUG FIT.

STEP 5:

- USE 5 - PCS. 2" X 3" X 47" INT'R PLASTIC SLAT (1)
 - 2 - PCS. 2" X 3" X 47" EDGE PLASTIC SLAT (2)
 - 21 - PCS. 5/16" X 1 1/2" SS. BTN. SKT. HD. LAG (10)
 - 21 - PCS. 5/16" SS. FLAT WASHER (12)
- ATTACH 2" X 3" X 47" PLASTIC SLATS (1 & 2) TO STEP 4 ASSEMBLY USING HARDWARE (10 & 12). TIGHTEN TO SNUG FIT. REPEAT UNTIL ALL SLATS ARE ATTACHED.

STEP 6:

UPON COMPLETION OF BENCH ASSEMBLY SQUARE ALL COMPONENTS THEN TIGHTEN ALL HARDWARE.

STEP 7:

MOUNT AND ANCHOR AS SPECIFIED.

ITEM	QTY	PART NO	DESCRIPTION
1	5	0-143-40PL-01	2" X 3" X 47" INTERIOR PLASTIC SLAT
2	2	0-143-40PL-02	2" X 3" X 47" PLASTIC EDGE SLAT
3	2	0-16-40-06	47" SEAT BRACE
4	1	0-57-40-04	47 3/4" PIPE BRACE
5	2	0-91-00-02	BKLESS CAST IRON BNCH SUPT
6	1	0-91-00-03	CENTER STRAP
7	2	0-91-00-04	END CONTOUR STRAP
8	6	1-12-116	5/16" X 1" SS BTN SKT HD CAP SCR
9	6	1-12-065	1/2" X 2 1/2" FLT SKT HD CAP SCR
10	21	1-13-023	5/16" X 1 1/2" SS BTN SKT HD LAG
11	6	1-20-016	5/16" SS NYLON LOCKNUT
12	33	1-22-017	5/16" SS FLAT WASHER

 DuMor, inc. P.O. Box 142 Mifflintown, PA 17059-0142	SCALE :	NONE	TITLE : <h2 style="margin: 0;">BENCH ASSEMBLY</h2>		
	DATE DRAWN :	1/10/02			
	DRAWN BY :	AWH	REV. : <h2 style="margin: 0;">D</h2>	DRAWING NUMBER <h2 style="margin: 0;">91-40PL</h2>	SHEET <h2 style="margin: 0;">2 OF 2</h2>
	DATE REV. :	12/03/09			
	REV. BY :	ESS			