

LENGTH OPTIONS

- 6' BENCH
- 8' BENCH

NOTES

1.) ALL STL. MEMBERS COATED W/ ZINC RICH EPOXY THEN FINISHED W/ POLYESTER POWDER COATING.

**DuMor, inc.**  
P.O. Box 142 Mifflintown, PA 17059-0142

SCALE :	NONE
DATE DRAWN :	2/22/94
DRAWN BY :	AH
DATE REV. :	12/11/98
REV. BY :	JSB

TITLE :	TEAM BENCH		
REV.	B	DRAWING NUMBER	97 SERIES A /S-5
			SHEET 1 OF 2

**NOTE:**

- 1.) DURING ASSEMBLY PROCEDURE;  
DO NOT COMPLETELY TIGHTEN HARDWARE.
- 2.) THE ACTUAL PARTS WILL NOT BE NUMBERED;  
NUMBERS ONLY APPLY TO DRAWING.

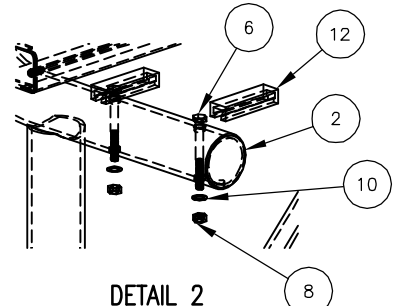
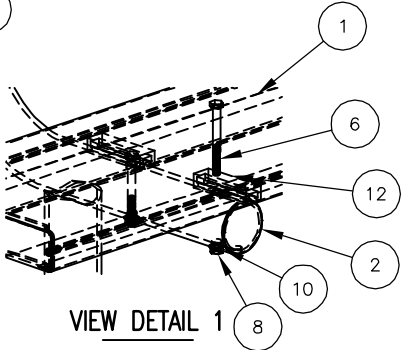
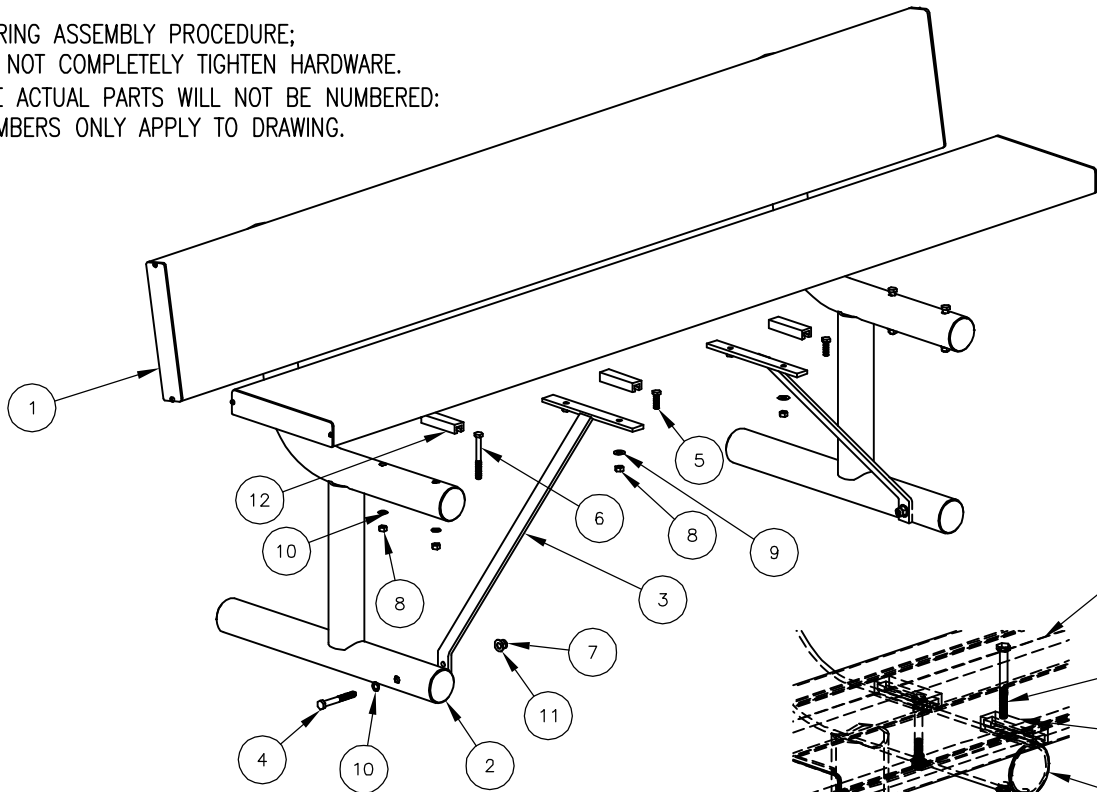

**STEP 1:**

USE 2 - PCS. FREE STANDING SUPPORT ( 2 )  
 8 - PCS. 5/16" X 3" SS. HEX HD. CAP SCR. ( 6 )  
 INSERT 5/16" X 3" SS. HEX HD. CAP SCR. ( 6 ) INTO EACH  
 BOLT HOLE IN THE FREE STANDING SUPPORT ( 2 ) FROM  
 THE TOP DOWN ( SEE DETAIL 1 )

**STEP 2:**

USE 2 - PCS. 2" X 10" X 6' ALUMINUM PLANK ( 1 )  
 8 - PCS. ALUMINUM CLIPS ( 12 )  
 8 - PCS. 5/16" SS. HEX NUT ( 8 )  
 8 - PCS. 3/8" ID. X 5/8" OD. RUBBER WASHER ( 10 )  
 SLIDE ALUMINUM CLIP ( 12 ) OVER HEAD OF 5/16" X 3"  
 S.STL. HEX HD. CAP SCR. ( 6 ). PLACE 2" X 10" X 6'  
 ALUMINUM PLANK ( 1 ) ON SUPPORT OVER TOP OF ALUMINUM  
 CLIP. TURN CLIP 1/4 TURN IN ALUMINUM PLANK TO LOCK INTO  
 PLACE. THEN USE HARDWARE ( 8 & 10 ) TO TIGHTEN TO SNUG  
 FIT. ( SEE DETAIL 2 )

**STEP 3:**

USE 2 - PCS. DIAGONAL (T) BRACE ( 3 )  
 2 - PCS. 3/8" X 3" S.STL. HEX HD. CAP SC. ( 4 )  
 2 - PCS. 3/8" S.STL. NYLON LOCK NUT ( 7 )  
 2 - PCS. 3/8" S.STL. FLAT WASHER ( 11 )  
 2 - PCS. 3/8" ID X 5/8" OD RUBBER WASHER ( 10 )  
 4 - PCS. ALUMINUM CLIPS ( 12 )  
 4 - PCS. 5/16" X 1" S.STL. CAP SCR. ( 5 )  
 4 - PCS. 5/16" S.STL. HEX NUT ( 8 )  
 4 - PCS. 5/16" S.STL. FLAT WASHER ( 9 )  
 ATTACH DIAGONAL (T) BRACE ( 3 ) TO STEP 2 ASSEMBLY  
 USING ALUMINUM CLIPS ( 12 ) AND HARDWARE ( 4, 5, 7, 8, 9,  
 10 & 11 ). TIGHTEN TO SNUG FIT.

**STEP 4:**

UPON COMPLETION OF BENCH ASSEMBLY SQUARE ALL  
 COMPONENTS THEN TIGHTEN ALL HARDWARE.

ITEM	QTY	PART NO	DESCRIPTION
1	2	0-71-60A-01	2" X 10" X 6' ALUMINUM PLANK
2	2	0-97-00-01/S-5	FREE-STANDING SUPPORT
3	2	0-97-00-02	DIAGONAL BRACE ( T )
4	2	1-12-002	3/8" X 3" SS HEX HD CAP SCR
5	4	1-12-061	5/16" X 1" SS HEX HD CAP SCR
6	8	1-12-076	5/16" X 3" S.STL. HEX HD CAP SCR
7	2	1-20-007	3/8" SS NYLON LOCKNUT
8	12	1-21-015	5/16" SS HEX NUT
9	4	1-22-017	5/16" SS FLAT WASHER
10	10	1-22-018	3/8" ID X 5/8" OD RUBBER WASHER
11	2	1-22-024	3/8" SS FLAT WASHER
12	12	5-48-083	ALUMINUM CLIPS

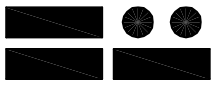
 <b>DuMor, inc.</b> P.O. Box 142 Mifflintown, PA 17059-0142	SCALE :	NONE	TITLE : <h2 style="margin: 0;">BENCH ASSEMBLY</h2>		
	DRAWN BY :	JSB			
	DATE REV. :	12/11/98	REV. : <h1 style="margin: 0;">B</h1>	DRAWING NUMBER : <h1 style="margin: 0;">97 SERIES A /S-5</h1>	SHEET 2 OF 2
	REV. BY :	JSB			