

NOTES

- 1.) ALL STL. MEMBERS COATED W/ ZINC RICH EPOXY THEN FINISHED W/ POLYESTER POWDER COATING.

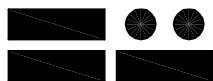

DuMor, inc.

P.O. Box 142 Mifflintown, PA 17059-0142

SCALE : NONE
 DATE DRAWN : 12/6/99
 DRAWN BY : JSB
 DATE REV. :
 REV. BY :

TITLE : TEAM BENCH

REV. A

DRAWING NUMBER 97-120A/S-5

SHEET 1 OF 2

NOTE:

- 1.) DURING ASSEMBLY PROCEDURE;
DO NOT COMPLETELY TIGHTEN HARDWARE.
- 2.) THE ACTUAL PARTS WILL NOT BE NUMBERED:
NUMBERS ONLY APPLY TO DRAWING.

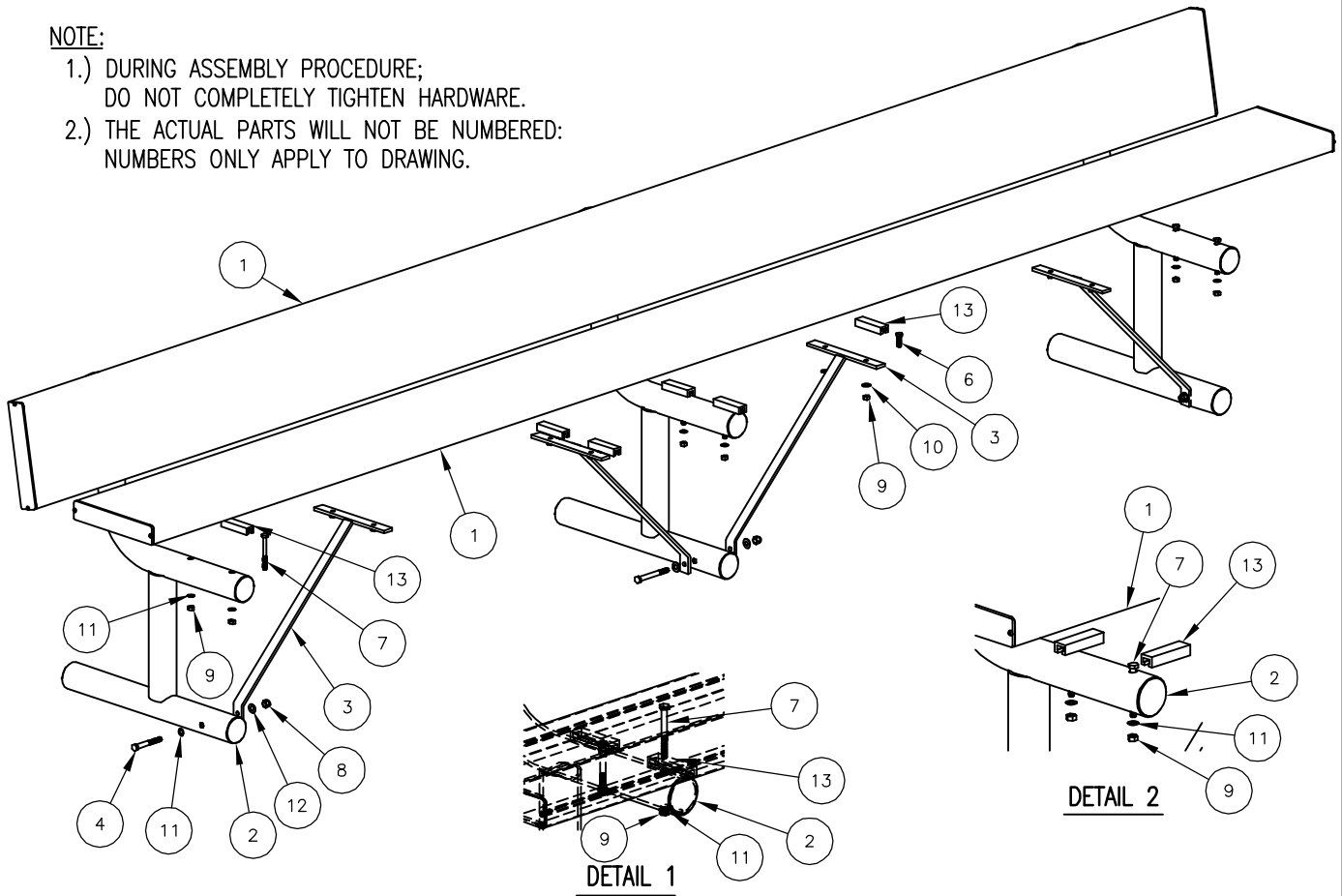

STEP 1:

USE 3 - PCS. FREE STANDING SUPPORT (2)
 12 - PCS. 5/16" X 3" SS. HEX HD. CAP SCR. (7)
 INSERT 5/16" X 3" SS. HEX HD. CAP SCR. (7) INTO EACH
 BOLT HOLE IN THE FREE STANDING SUPPORT (2) FROM
 THE TOP DOWN (SEE DETAIL 1)

STEP 2:

USE 2 - PCS. 2" X 10" X 12' ALUMINUM PLANK (1)
 12 - PCS. ALUMINUM CLIPS (13)
 12 - PCS. 5/16" SS. HEX NUT (9)
 12 - PCS. 3/8" ID. X 5/8" OD. RUBBER WASHER (11)
 SLIDE ALUMINUM CLIP (13) OVER HEAD OF 5/16" X 3"
 S.STL. HEX HD. CAP SCR. (7). PLACE 2" X 10" X 12'
 ALUMINUM PLANK (1) ON SUPPORT OVER TOP OF ALUMINUM
 CLIP. TURN CLIP 1/4 TURN IN ALUMINUM PLANK TO LOCK INTO
 PLACE. THEN USE HARDWARE (9 & 11) TO TIGHTEN TO
 SNUG FIT. (SEE DETAIL 2)

STEP 3:

USE 2 - PCS. DIAGONAL (T) BRACE (3)
 2 - PCS. 3/8" X 3" S.STL. HEX HD. CAP SCR. (4)
 2 - PCS. 3/8" S.STL. NYLON LOCK NUT (8)
 2 - PCS. 3/8" S.STL. FLAT WASHER (12)
 2 - PCS. 3/8" ID X 5/8" OD RUBBER WASHER (11)
 4 - PCS. ALUMINUM CLIPS (13)
 4 - PCS. 5/16" X 1" S.STL. CAP SCR. (6)
 4 - PCS. 5/16" S.STL. HEX NUT (9)
 4 - PCS. 5/16" S.STL. FLAT WASHER (10)
 ATTACH DIAGONAL (T) BRACE (3) TO END SUPPORTS
 USING HARDWARE (4, 8, 11, & 12) AND ALUMINUM CLIPS
 (13) TIGHTEN TO SNUG FIT.

STEP 4:

USE 2 - PCS. DIAGONAL (T) BRACE (3)
 1 - PC. 3/8" X 3 1/2" S.STL. HEX HD. CAP SCR. (5)
 1 - PCS. 3/8" S.STL. NYLON LOCK NUT (8)
 2 - PCS. 3/8" S.STL. FLAT WASHER (12)
 4 - PCS. ALUMINUM CLIPS (13)
 4 - PCS. 5/16" X 1" S.STL. CAP SCR. (6)
 4 - PCS. 5/16" S.STL. HEX NUT (9)
 4 - PCS. 5/16" S.STL. FLAT WASHER (10)
 ATTACH DIAGONAL (T) BRACE (3) TO EACH SIDE OF CENTER SUPPORT
 LEG OF STEP 3 ASSEMBLY USING HARDWARE (5, 6, 8, 9, 10, & 12)
 AND ALUMINUM CLIPS (13) TIGHTEN TO SNUG FIT.

STEP 5:

UPON COMPLETION OF BENCH ASSEMBLY SQUARE ALL
 COMPONENTS THEN TIGHTEN ALL HARDWARE.

ITEM	QTY	PART NO	DESCRIPTION
1	2	0-71-120A-01	2" X 10" X 12' ALUM. PLANK
2	3	0-97-00-01/S-5	FREE-STANDING SUPPORT
3	4	0-97-00-02	DIAGONAL BRACE (T)
4	2	1-12-002	3/8" X 3" SS HEX HD CAP SCR
5	1	1-12-034	3/8" X 3 1/2" SS HEX HD CAP SCR
6	8	1-12-061	5/16" X 1" SS HEX HD CAP SCR
7	12	1-12-076	5/16" X 3" S.STL. HEX HD CAP SCR
8	3	1-20-007	3/8" SS NYLON LOCKNUT
9	20	1-21-015	5/16" SS HEX NUT
10	8	1-22-017	5/16" SS FLAT WASHER
11	14	1-22-018	3/8" ID X 5/8" OD RUBBER WASHER
12	4	1-22-024	3/8" SS FLAT WASHER
13	20	5-48-083	ALUMINUM CLIPS

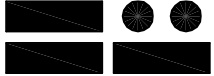

DuMor, inc.
P.O. Box 142 Mifflintown, PA 17059-0142

SCALE : NONE

TITLE : BENCH ASSEMBLY

DATE DRAWN : 12/6/99

DRAWN BY : JSB

REV. : A

DATE REV. :

REV. BY :

DRAWING NUMBER 97-120A/S-5

SHEET 2 OF 2