

- |   |   |
|---|---|
| <u>W/ 2" x 4" SLATS</u>                     | <u>W/ 3" x 4" SLATS</u>                     |
| <input type="checkbox"/> 98-82 ( 8' BENCH ) | <input type="checkbox"/> 98-83 ( 8' BENCH ) |

NOTES

- 1.) ALL STL. MEMBERS COATED W/ ZINC RICH EPOXY THEN FINISHED W/ POLYESTER POWDER COATING.
- 2.) ALL WOOD MEMBERS TREATED W/ CLEAR PRESERVATIVE.
- 3.) 1/2" X 3 3/4" EXPANSION ANCHOR BOLTS PROVIDED.

WOOD OPTIONS

- CLEAR ALL HEART REDWOOD S4S EE
- 'C' & BTR. DOUGLAS FIR KD S4S EE
- OTHER \_\_\_\_\_



**DuMor, inc.**  
P.O. Box 142 Mifflintown, PA 17059-0142

SCALE : NONE  
 DATE DRAWN : 12/6/99  
 DRAWN BY : JSB  
 DATE REV. : 12/15/08  
 REV. BY : ESS

TITLE : BENCH		DRAWING NUMBER : 98-80	SHEET : 1 OF 2
REV. : C			

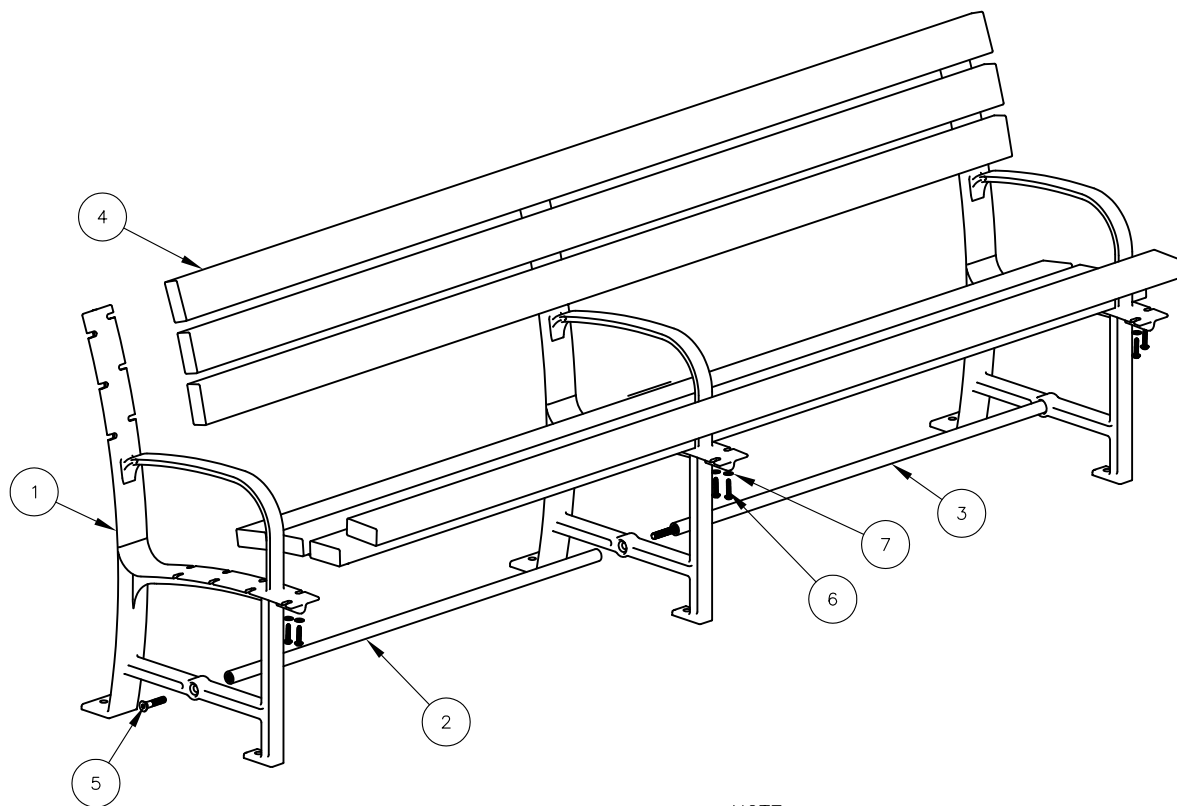

**STEP 1:**

USE 1 - PC. CAST IRON SUPPORT ( 1 )  
 1 - PC. 43 3/8" PIPE BRACE ( 2 )  
 1 - PC. 43 3/8" PIPE BRACE WITH STUD ( 3 )  
 ATTACH PIPE BRACES ( 2 & 3 ) TO CAST IRON SUPPORT ( 1 ) BY INSERTING PIPE BRACE WITH STUD ( 3 ) THROUGH CAST SUPPORT AND ATTACH PIPE BRACE ( 2 ) TO END OF STUD. TIGHTEN TO SNUG FIT.

**STEP 2:**

USE 2 - PCS. CAST IRON SUPPORT ( 1 )  
 2 - PCS. 1/2" X 2 1/2" FLT. SKT. HD. CAP SCR. ( 5 )  
 ATTACH CAST IRON SUPPORT ( 1 ) TO STEP 1 ASSEMBLY USING HARDWARE ( 5 ). TIGHTEN TO SNUG FIT.

**STEP 3:**

USE 7 - PCS. 2" X 4" X 95" WOOD SLAT ( 4 )  
 42 - PCS. 5/16" X 1 1/2" SS. BTN. SKT. HD. LAG ( 6 )  
 42 - PCS. 5/16" SS. FLAT WASHER ( 7 )  
 ATTACH 2" X 4" X 95" WOOD SLAT ( 4 ) TO STEP 2 ASSEMBLY USING HARDWARE ( 6 & 7 ). TIGHTEN TO SNUG FIT. REPEAT UNTIL ALL SLATS ARE ATTACHED.

**NOTE:**

- 1.) DURING ASSEMBLY PROCEDURE;  
DO NOT COMPLETELY TIGHTEN HARDWARE.
- 2.) THE ACTUAL PARTS WILL NOT BE NUMBERED;  
NUMBERS ONLY APPLY TO DRAWING.

**STEP 4:**

UPON COMPLETION OF BENCH ASSEMBLY SQUARE ALL COMPONENTS THEN TIGHTEN ALL HARDWARE.

**STEP 5:**

MOUNT AND ANCHOR AS SPECIFIED.

ITEM	QTY	PART NO	DESCRIPTION
1	3	0-98-00-02	CAST IRON SUPPORT (98)
2	1	0-98-80-03	3/4" SCH 40 PIPE BRACE ( 43 3/8" )
3	1	0-98-80-04	3/4" SCH 40 PIPE BRACE 43 3/8" W/ STUD
4	7	0-98-82-01	2" X 4" X 95" WOOD SLAT
5	2	1-12-065	1/2" X 2 1/2" FLT SKT HD CAP SCR
6	42	1-13-023	5/16" X 1 1/2" SS BTN SKT HD LAG
7	42	1-22-017	5/16" SS FLAT WASHER

**DuMor, inc.**  
 P.O. Box 142 Mifflintown, PA 17059-0142

SCALE : NONE  
 DATE DRAWN : 12/8/99  
 DRAWN BY : JSB  
 DATE REV. : 12/15/08  
 REV. BY : ESS

TITLE : BENCH ASSEMBLY

REV. C	DRAWING NUMBER 98-80	SHEET 2 OF 2
--------	----------------------	--------------