

LENGTH OPTIONS

- 6' BENCH
- 8' BENCH

SLAT OPTIONS

- "CEDAR" RECYCLED PLASTIC
- "GREEN" RECYCLED PLASTIC
- "GREY" RECYCLED PLASTIC
- "REDWOOD" RECYCLED PLASTIC
- "WALNUT" RECYCLED PLASTIC
- OTHER _____

NOTES:

- 1.) ALL STL. MEMBERS COATED W/ ZINC RICH EPOXY THEN FINISHED W/ POLYESTER POWDER COATING.



DuMor, inc.

P.O. Box 142 Mifflintown, PA 17059-0142

SCALE : NONE
 DATE DRAWN : 7/26/95
 DRAWN BY : AH
 DATE REV. : 12/03/09
 REV. BY : ESS

TITLE : TEAM BENCH

REV. C

DRAWING NUMBER 99 SERIES PL /S-1

SHEET 1 OF 2

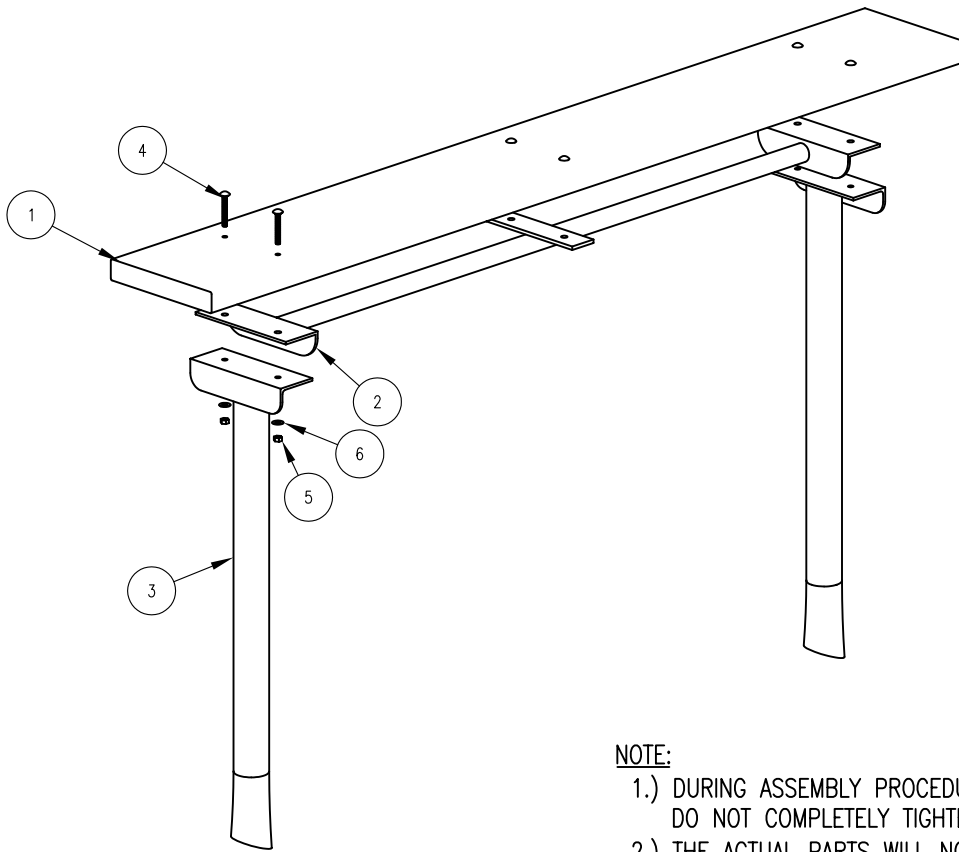

NOTE:

- 1.) DURING ASSEMBLY PROCEDURE;
DO NOT COMPLETELY TIGHTEN HARDWARE.
- 2.) THE ACTUAL PARTS WILL NOT BE NUMBERED;
NUMBERS ONLY APPLY TO DRAWING.

STEP 1:

- USE 1 – PC. 2" X 10" X 71" PLASTIC SLAT (1)
- 1 – PC. 6' SEAT BRACE (2)
- 2 – PCS. 5/16" X 2 1/4" SS. CGE. BOLT(4)
- 2 – PCS. 5/16" SS. FLAT WASHER (6)
- 2 – PCS. 5/16" SS. HEX NUT (5)

ATTACH 2" X 10" X 71" PLASTIC SLAT (1) TO CENTER PLATE ONLY ON 6' SEAT BRACE (2) USING HARDWARE (4, 5, & 6). TIGHTEN TO SNUG FIT.

STEP 2:

- USE 2 – PCS. SUPPORT FOR EMBEDMENT (3)
- 4 – PCS. 5/16" X 2 1/4" SS. CGE. BOLT(4)
- 4 – PCS. 5/16" SS. FLAT WASHER (6)
- 4 – PCS. 5/16" SS. HEX NUT (5)

ATTACH STEP 1 ASSEMBLY TO SUPPORT FOR EMBEDMENT (3) USING HARDWARE (4, 5, & 6). TIGHTEN TO SNUG FIT.

STEP 3:

UPON COMPLETION OF BENCH ASSEMBLY SQUARE ALL COMPONENTS THEN TIGHTEN ALL HARDWARE.

STEP 4:

MOUNT AND ANCHOR AS SPECIFIED.

ITEM	QTY	PART NO	DESCRIPTION
1	1	0-71-60PL-01	2" X 10" X 71" PLASTIC SLAT
2	1	0-77-60-14	6' SEAT BRACE
3	2	0-99-00-01/S-1	SUPPORT FOR EMBEDMENT
4	6	1-11-062	5/16" X 2 1/4" SS CGE BOLT
5	6	1-21-015	5/16" SS HEX NUT
6	6	1-22-017	5/16" SS FLAT WASHER

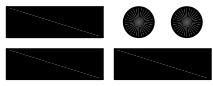
 DuMor, inc. P.O. Box 142 Mifflintown, PA 17059-0142	SCALE :	NONE	TITLE : BENCH ASSEMBLY	
	DATE DRAWN :	1/14/00		
	DRAWN BY :	JSB	REV.	DRAWING NUMBER 99 SERIES PL /S-1
	DATE REV. :	12/03/09	C	
REV. BY :	ESS			