

LENGTH OPTIONS

- 6' TABLE
- 8' TABLE

NOTES

- 1.) ALL STL. MEMBERS COATED W/ ZINC RICH EPOXY THEN FINISHED W/ POLYESTER POWDER COATING.
- 2.) ALL WELDS CONT. THEN GROUND SMOOTH.
- 3.) 1/2" X 3 3/4" EXPANSION ANCHOR BOLTS PROVIDED

DuMor, inc.
 P.O. Box 142 Mifflintown, PA 17059-0142

SCALE : NONE
 DATE DRAWN : 9/6/12
 DRAWN BY : JSB
 DATE REV. :
 REV. BY :

TITLE : TABLE		DRAWING NUMBER 443 SERIES/S-2	SHEET 1 OF 2
REV. A			

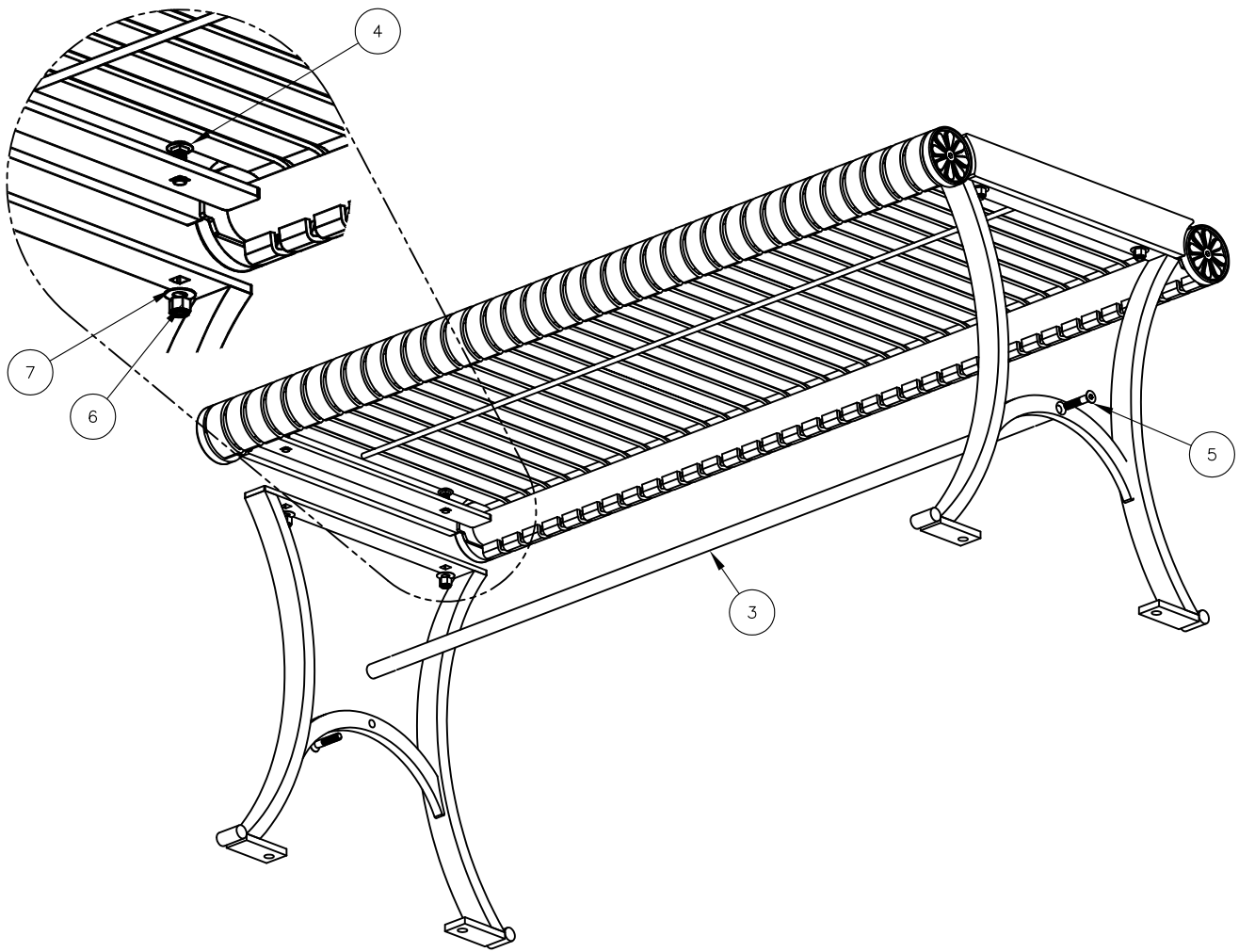

NOTES:

- 1.) DURING ASSEMBLY PROCEDURE;
DO NOT COMPLETELY TIGHTEN HARDWARE.
- 2.) THE ACTUAL PARTS WILL NOT BE NUMBERED;
NUMBERS ONLY APPLY TO DRAWING.

STEP 1:

USE 1 - PC. 3/4" SCH 40 PIPE BRACE (68 1/4") (3)
 2 - PCS. TABLE SUPPORT FOR SURFACE MOUNT (1)
 2 - PCS. 1/2" X 2 1/2" FLT SKT HD. CAP SCR. (5)
 BOLT 3/4" SCH 40 PIPE BRACE (68 1/4") (3) TO TABLE SUPPORT
 FOR SURFACE MOUNT (1) USING HARDWARE (5). TIGHTEN TO SNUG FIT.

STEP 2:

USE 1 - PC. 71 1/2" STL TABLE TOP, 30", 92 STYLE ASSEMBLY (2)
 4 - PCS. 1/2" X 1 1/2" SS CGE BOLT (4)
 4 - PCS. 1/2" SS. FLAT WASHER (7)
 4 - PCS. 1/2" SS. NYLON LOCKNUT (6)
 ATTACH 71 1/2" STL TABLE TOP, 30", 92 STYLE ASSEMBLY (2) TO STEP 1
 ASSEMBLY USING HARDWARE (4, 6, & 7). TIGHTEN TO SNUG FIT.

STEP 3:

UPON COMPLETION OF TABLE ASSEMBLY SQUARE ALL COMPONENTS THEN
 TIGHTEN ALL HARDWARE.

ITEM	QTY	PART NO	DESCRIPTION
1	2	0-443-00-01/S-2	TABLE SUPPORT FOR SURFACE MOUNT
2	1	0-443-60-02	71 1/2" STL TABLE TOP,30",92 STYLE ASSEMBLY
3	1	0-PB12-68-04	3/4" SCH 40 PIPE BRACE (68 1/4")
4	4	1-11-042	1/2" X 1 1/2" SS CGE BOLT
5	2	1-12-065	1/2" X 2 1/2" FLT SKT HD CAP SCR
6	4	1-20-015	1/2" SS NYLON LOCKNUT
7	4	1-22-015	1/2" SS FLAT WASHER

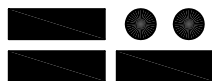

DuMor, inc.

P.O. Box 142 Mifflintown, PA 17059-0142

SCALE : NONE

DATE DRAWN : 9/6/12

DRAWN BY : JSB

DATE REV. :

REV. BY :

TITLE :

TABLE ASSEMBLY

REV.

DRAWING
NUMBER

A

443 SERIES/S-2

SHEET
2 OF 2