

LETTERING LAYOUT
 TRASH (20 GAL)
 BOTTLES & CANS (20 GAL)

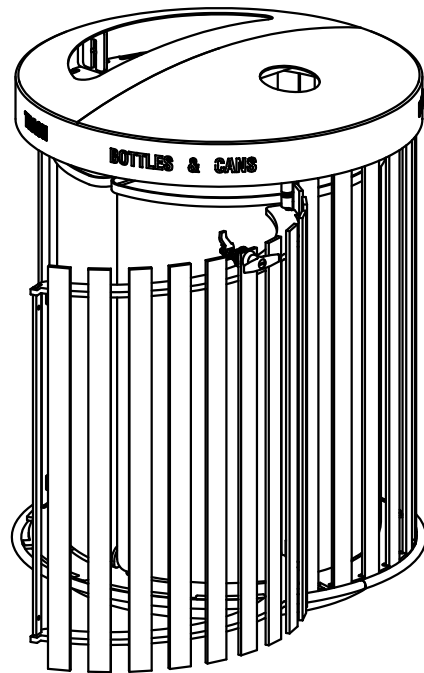
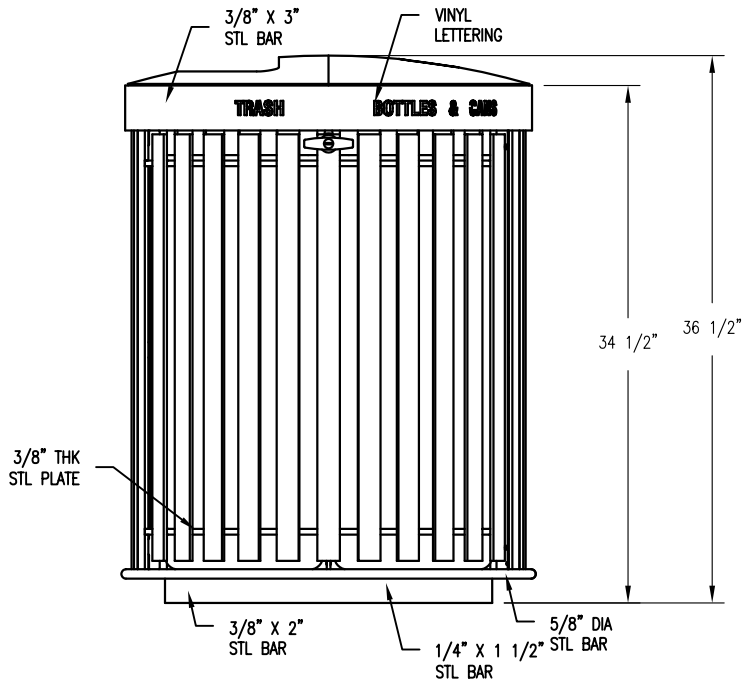

COVER NUMBERS

- 0-434-EC-13 (1/2 MOON OPENING)
- 0-434-EC-10 (4" OPENING)

NOTES

- 1.) ALL STL. MEMBERS COATED W/ ZINC RICH EPOXY THEN FINISHED W/ POLYESTER POWDER COATING.
- 2.) 1/2" X 3 3/4" EXPANSION ANCHOR BOLTS PROVIDED (QTY 3).
- 3.) RECYCLING UNIT HINGE FOR REMOVAL OF LINERS.



DuMor, inc.
 P.O. Box 142 Mifflintown, PA 17059-0142

SCALE : NONE
 DATE DRAWN : 10/5/11
 DRAWN BY : JSB
 DATE REV. :
 REV. BY :

TITLE : RECYCLING UNIT

REV. A
 DRAWING NUMBER 436-40-0001

SHEET 1 OF 2

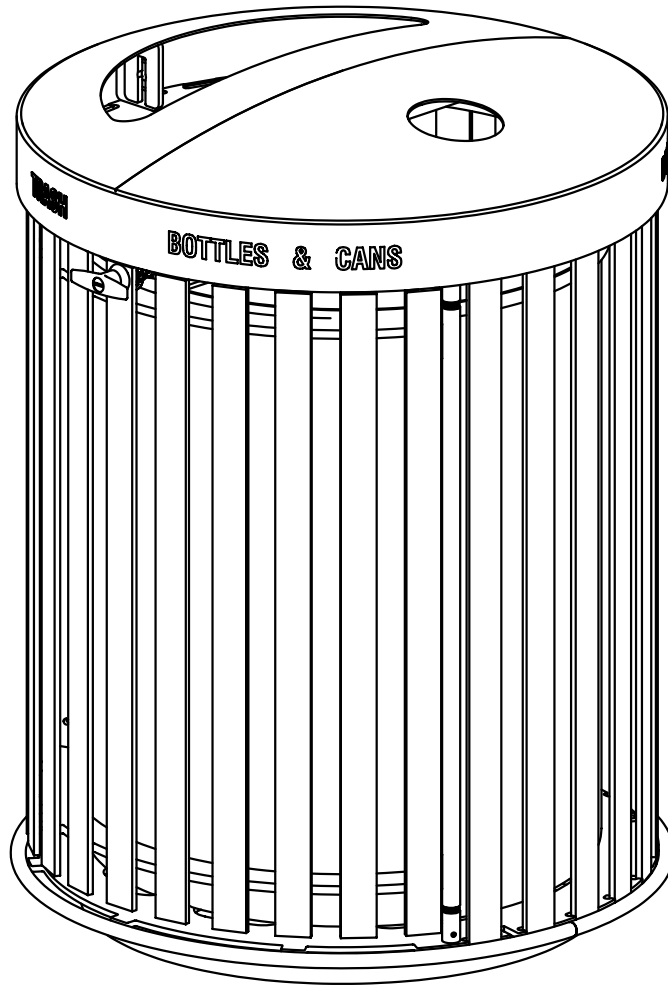

NOTE:

- 1.) RECEPTACLE SHIPPED FULLY ASSEMBLED.
- 2.) MOUNT AND ANCHOR AS SPECIFIED.



DuMor, inc.

P.O. Box 142 Mifflintown, PA 17059-0142

SCALE :	NONE
DATE DRAWN :	10/13/11
DRAWN BY :	JSB
DATE REV. :	
REV. BY :	

TITLE :		RECYCLING UNIT ASSEMBLY	
REV.	DRAWING NUMBER		
A	436-40-0001		
		SHEET	2 OF 2