

CUSTOM LETTERING ( 37 SPACES ) \_\_\_\_\_

**NOTES**

- 1.) ALL STL. MEMBERS COATED W/ ZINC RICH EPOXY THEN FINISHED W/ POLYESTER POWDER COATING.
- 2.) 1/2" X 3 3/4" EXPANSION ANCHOR BOLTS PROVIDED.
- 3.) CUSTOM LETTERING AVAILABLE FOR RECESSED SIDE PANELS ( TOTAL OF 37 SPACES ).

**SLAT OPTIONS**

- "CEDAR" RECYCLED PLASTIC
- "GREY" RECYCLED PLASTIC
- "REDWOOD" RECYCLED PLASTIC
- "WALNUT" RECYCLED PLASTIC
- OTHER \_\_\_\_\_

  
**DuMor, inc.**  
 P.O. Box 142 Mifflintown, PA 17059-0142

SCALE : NONE  
 DATE DRAWN : 12/11/01  
 DRAWN BY : AH  
 DATE REV. : 10/25/11  
 REV. BY : RDH

TITLE : BENCH

REV. E

DRAWING NUMBER

57-80PL

SHEET 1 OF 2

**NOTE:**

- 1.) DURING ASSEMBLY PROCEDURE;  
DO NOT COMPLETELY TIGHTEN HARDWARE.
- 2.) THE ACTUAL PARTS WILL NOT BE NUMBERED.  
NUMBERS ONLY APPLY TO DRAWING.

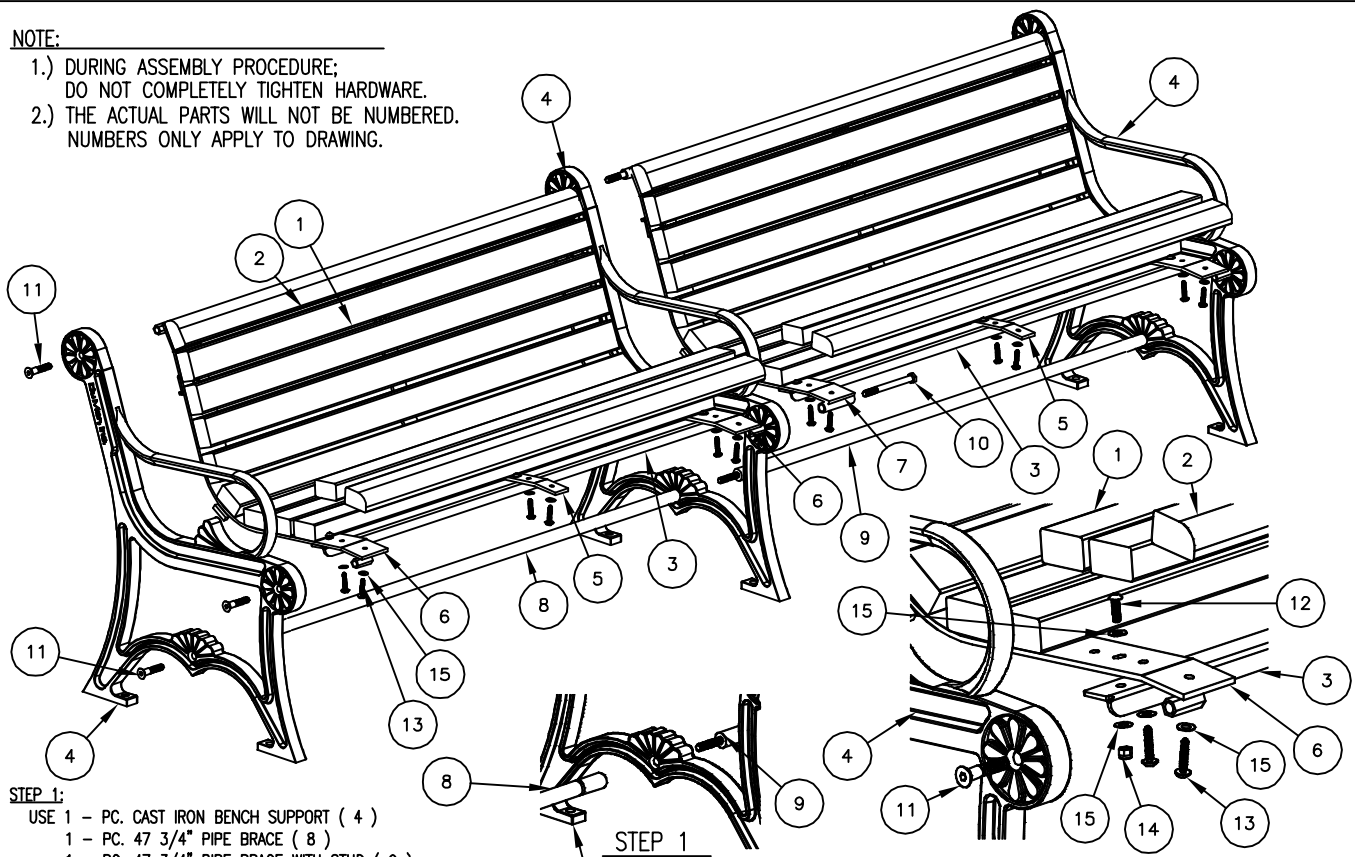

**STEP 1:**

- USE 1 - PC. CAST IRON BENCH SUPPORT ( 4 )  
 1 - PC. 47 3/4" PIPE BRACE ( 8 )  
 1 - PC. 47 3/4" PIPE BRACE WITH STUD ( 9 )
- ATTACH PIPE BRACES TO CAST IRON BENCH SUPPORT ( 4 ) BY INSERTING PIPE BRACE WITH STUD ( 9 ) THROUGH CAST SUPPORT ( 4 ) THEN ATTACH PIPE BRACE ( 8 ) TO END OF STUD. TIGHTEN TO SNUG FIT.

**STEP 2:**

- USE 2 - PCS. CAST IRON BENCH SUPPORT ( 4 )  
 2 - PCS. 1/2" X 2 1/2" FLT. SKT. HD. CAP SCR ( 11 )
- ATTACH CAST IRON BENCH SUPPORTS ( 4 ) TO STEP 1 ASSEMBLY USING HARDWARE ( 11 ). TIGHTEN TO SNUG FIT.

**STEP 3:**

- USE 2 - PCS. END CONTOUR STRAP ( 6 )  
 4 - PCS. 1/2" X 2 1/2" FLT. SKT. HD. CAP SCR. ( 11 )
- ATTACH END CONTOUR STRAP ( 6 ) TO STEP 2 ASSEMBLY END SUPPORTS USING HARDWARE ( 11 ). TIGHTEN TO SNUG FIT.

**STEP 4:**

- USE 1 - PC. END CONTOUR STRAP ( 6 )  
 1 - PC. CONTOUR STRAP FOR CENTER LEG ( 7 )  
 2 - PCS. 1/2" X 5 1/2" SS. HEX HD. CAP SCR. ( 10 )
- ATTACH END CONTOUR STRAP ( 6 ) AND CONTOUR STRAP FOR CENTER LEG ( 7 ) TO THE CENTER LEG OF STEP 3 ASSEMBLY USING HARDWARE ( 10 ). TIGHTEN TO SNUG FIT.

**STEP 5:**

- USE 4 - PCS. 47" SEAT BRACE ( 3 )  
 8 - PCS. 5/16" X 1" SS. BTN SKT HD CAP SCR ( 12 )  
 8 - PCS. 5/16" SS. NYLON LOCKNUT ( 14 )  
 16 - PCS. 5/16" SS. FLAT WASHER ( 15 )
- ATTACH 47" SEAT BRACE ( 3 ) TO STEP 4 ASSEMBLY USING HARDWARE ( 12, 14, & 15 ). TIGHTEN TO SNUG FIT.

**STEP 6:**

- USE 2 - PCS. CENTER CONTOUR STRAP ( 5 )  
 4 - PCS. 5/16" X 1" SS. BTN SKT HD CAP SCR ( 12 )  
 4 - PCS. 5/16" SS. NYLON LOCKNUT ( 14 )  
 8 - PCS. 5/16" SS. FLAT WASHER ( 15 )
- ATTACH CENTER CONTOUR STRAP ( 5 ) TO STEP 5 ASSEMBLY USING HARDWARE ( 12, 14, & 15 ). TIGHTEN TO SNUG FIT.

**STEP 7:**

- USE 18 - PCS. 2" X 3" X 47" PLASTIC INT'R SLAT ( 1 )  
 4 - PCS. 2" X 3" X 47" PLASTIC EDGE SLAT ( 2 )  
 66 - PCS. 5/16" X 1 1/2" SS. BTN. SKT. HD. LAG ( 13 )  
 66 - PCS. 5/16" SS. FLAT WASHER ( 15 )
- ATTACH 2" X 3" X 47" PLASTIC SLATS ( 1 & 2 ) TO STEP 6 ASSEMBLY USING HARDWARE ( 13 & 15 ). TIGHTEN TO SNUG FIT. REPEAT UNTIL ALL SLATS ARE ATTACHED.

**DETAIL A**

**STEP 8:**

UPON COMPLETION OF BENCH ASSEMBLY SQUARE ALL COMPONENTS THEN TIGHTEN ALL HARDWARE.

**STEP 9:**

MOUNT AND ANCHOR AS SPECIFIED.

ITEM	QTY	PART NO	DESCRIPTION
1	18	0-143-40PL-01	2" X 3" X 47" INTERIOR PLASTIC SLAT
2	4	0-143-40PL-02	2" X 3" X 47" PLASTIC EDGE SLAT
3	4	0-16-40-06	47" SEAT BRACE
4	3	0-57-00-02	CAST IRON BENCH SUPPORT
5	2	0-57-00-03	CENTER CONTOUR STRAP
6	3	0-57-00-05	END CONTOUR STRAP
7	1	0-57-00-06	END STRAP FOR CTR SUPPORT
8	1	0-57-40-04	47 3/4" PIPE BRACE
9	1	0-57-40-05	47 3/4" PIPE BRACE WITH STUD
10	2	1-12-040	1/2" X 5 1/2" SS HEX HD CAP SCR
11	6	1-12-065	1/2" X 2 1/2" FLT SKT HD CAP SCR
12	12	1-12-116	5/16" X 1" SS BTN SKT HD CAP SCR
13	66	1-13-023	5/16" X 1 1/2" SS BTN SKT HD LAG
14	12	1-20-016	5/16" SS NYLON LOCKNUT
15	90	1-22-017	5/16" SS FLAT WASHER

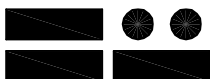

**DuMor, inc.**

P.O. Box 142 Mifflintown, PA 17059-0142

SCALE : NONE

DATE DRAWN : 12/11/01

DRAWN BY : AWH

DATE REV. : 10/25/11

REV. BY : RDH

TITLE : BENCH ASSEMBLY

REV.

DRAWING NUMBER

57-80PL

SHEET

2 OF 2