

S-2 SURFACE

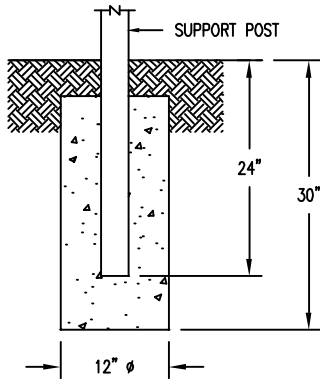

S-1 EMBEDMENT

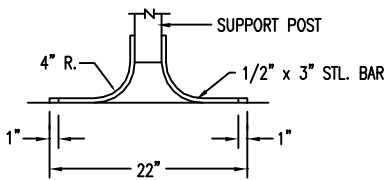

S-3 GULL WING

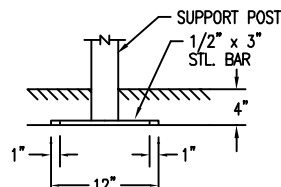

S-4 SUB FLOOR

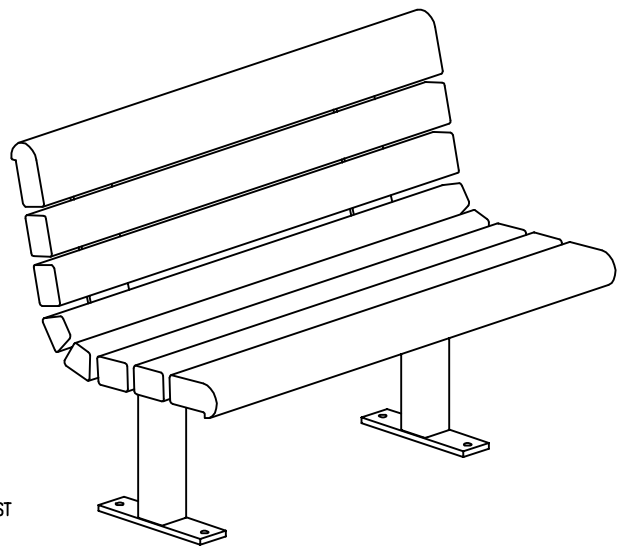
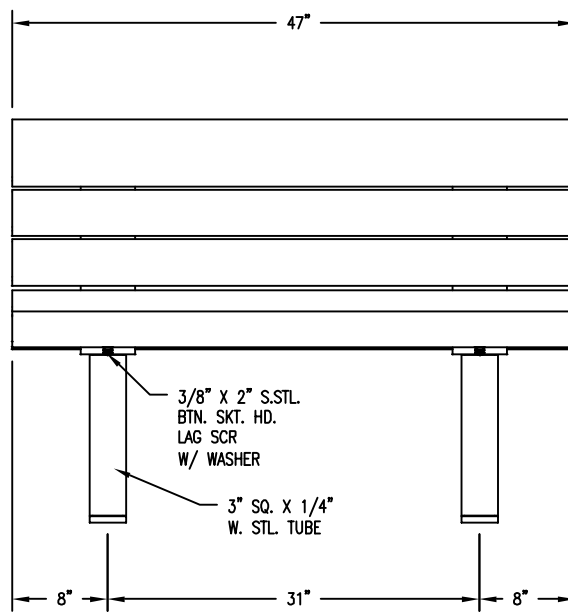

SLAT OPTIONS

- "CEDAR" RECYCLED PLASTIC
- "GREY" RECYCLED PLASTIC
- "REDWOOD" RECYCLED PLASTIC
- "WALNUT" RECYCLED PLASTIC
- OTHER _____

NOTES:

- 1.) ALL STL. MEMBERS COATED W/ ZINC RICH EPOXY THEN FINISHED W/ POLYESTER POWDER COATING.
- 2.) 1/2" X 3 3/4" EXPANSION ANCHOR BOLTS PROVIDED FOR OPTIONS S-2, S-3, & S-4.

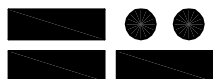

DuMor, inc.

P.O. Box 142 Mifflintown, PA 17059-0142

SCALE : NONE
 DATE DRAWN : 1/22/96
 DRAWN BY : JSB
 DATE REV. : 10/25/11
 REV. BY : RDH

TITLE : BENCH

REV. D

DRAWING NUMBER 88-40PL

SHEET 1 OF 2

SURFACE MOUNT
OPTION SHOWN

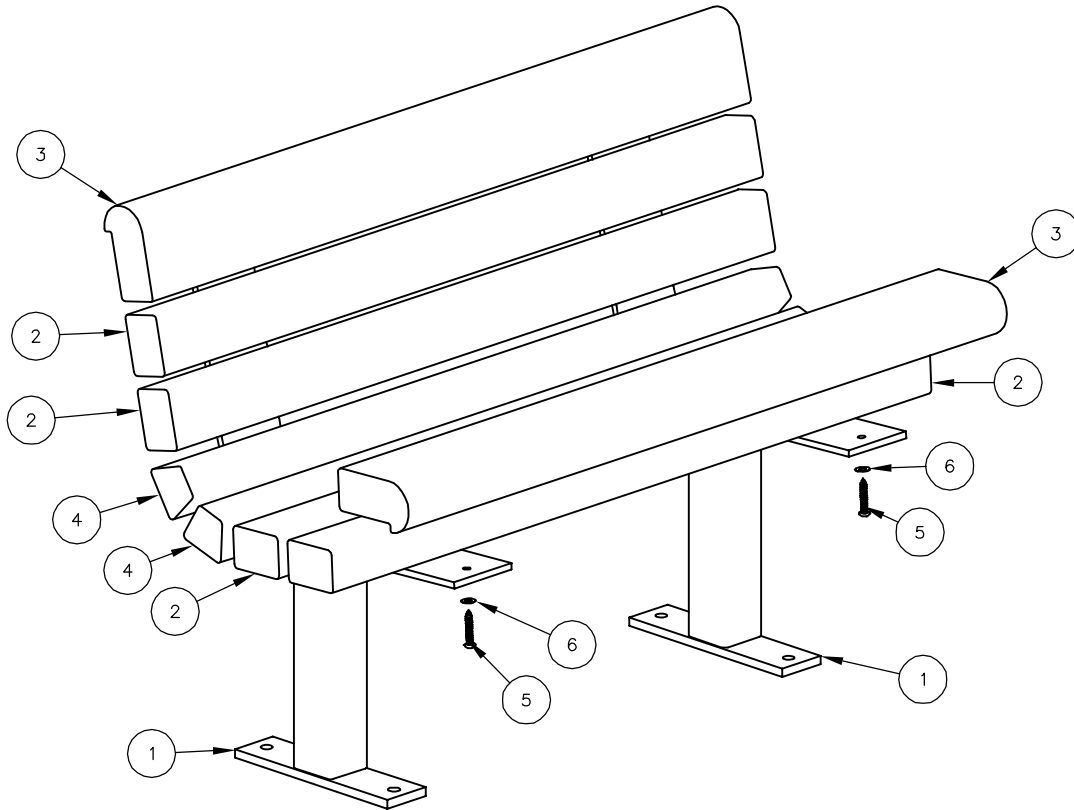

NOTE:

- 1.) DURING ASSEMBLY PROCEDURE;
DO NOT COMPLETELY TIGHTEN HARDWARE.
- 2.) THE ACTUAL PARTS WILL NOT BE NUMBERED:
NUMBERS ONLY APPLY TO DRAWING.
- 3.) SEE SPEC. SHEET 1 FOR MOUNTING OPTION.

STEP 1:

- USE 3 - PC. SUPPORT FOR SURFACE MOUNT (1)
- 4 - PCS. 3" X 4" X 47" PLASTIC INT'R SLAT (2)
- 2 - PCS. 47" PLASTIC EDGE SLAT (3)
- 2 - PCS. 47" PLASTIC TRAP SLAT (4)
- 24 - PCS. 3/8" X 2" SS. BTN. SKT. HD. LAG SCR. (5)
- 24 - PCS. 3/8" SS. FLAT WASHER (6)

ATTACH SLATS (2, 3, & 4) TO SUPPORT FOR SURFACE MOUNT (1) USING HARDWARE (5 & 6). TIGHTEN TO SNUG FIT.
REPEAT UNTIL ALL SLATS ARE ATTACHED.

STEP 2:

UPON COMPLETION OF BENCH ASSEMBLY SQUARE ALL COMPONENTS THEN TIGHTEN ALL HARDWARE.

STEP 3:

ANCHOR ACCORDING TO SUPPORT OPTION USED.

ITEM	QTY	PART NO	DESCRIPTION
1	2	0-88-00-01/S-2	BENCH SUPPORT FOR SURFACE MOUNT
2	4	0-88-40PL-02	3" X 4" X 47" PLASTIC SLAT
3	2	0-88-40PL-03	47" PLASTIC EDGE SLAT
4	2	0-88-40PL-04	47" PLASTIC TRAP SLAT
5	16	1-13-016	3/8" X 2" SS BTN SKT HD LAG SCR
6	16	1-22-024	3/8" SS FLAT WASHER

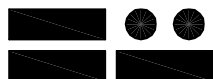

DuMor, inc.

P.O. Box 142 Mifflintown, PA 17059-0142

SCALE : NONE
DATE DRAWN : 1/22/96
DRAWN BY : JSB
DATE REV. : 10/25/11
REV. BY : RDH

TITLE : BENCH

REV. D

DRAWING NUMBER

88-40PL

SHEET 2 OF 2