

1/2" X 2 1/2"
S.STL. FLT SKT
HD CAP SCR

NOTES

- 1.) ALL STL. MEMBERS COATED W/ ZINC RICH EPOXY THEN FINISHED W/ POLYESTER POWDER COATING.
- 2.) ALL WELDS CONT. THEN GROUND SMOOTH.
- 3.) 1/2" X 3 3/4" EXPANSION ANCHOR BOLTS PROVIDED

NOTES:

- 1.) DURING ASSEMBLY PROCEDURE;
DO NOT COMPLETELY TIGHTEN HARDWARE.
- 2.) THE ACTUAL PARTS WILL NOT BE NUMBERED.
NUMBERS ONLY APPLY TO DRAWING.
- 3.) UPON COMPLETION OF ASSEMBLY SQUARE
ALL COMPONENTS THEN TIGHTEN ALL HARDWARE.
- 4.) MOUNT AND ANCHOR AS SPECIFIED.

TOOLS REQ'D

- 3/4" WRENCH
- 5/16" ALLEN WRENCH
- 1/2" MASONRY DRILL BIT
- DRILL
- RATCHET STRAP (PROVIDED)

PARTS LIST FOR S-2

ITEM	QTY	PART NO	DESCRIPTION
1	2	0-443-00-01/S-2	TABLE SUPPORT FOR SURFACE MOUNT
2	1	0-443-80-02	95 1/2" STL TABLE TOP,30",92 STYLE ASSEMBLY
2	2	0-57-50-04	3/4" SCH 40 PIPE BRACE (59 3/4")
3	4	0-91-00-02	BKLESS CAST IRON BNCH SUPT
4	2	0-92-50-01	5' STL SEAT
5	1	0-PB12-61-04	3/4" SCH 40 PIPE BRACE (61 1/4")
6	4	1-11-042	1/2" X 1 1/2" SS CGE BOLT
7	14	1-12-065	1/2" X 2 1/2" FLT SKT HD CAP SCR
8	4	1-20-015	1/2" SS NYLON LOCKNUT
9	4	1-22-015	1/2" SS FLAT WASHER

KITS PROVIDED FOR S-2

ITEM	QTY	PART NO	DESCRIPTION
10	3	K-ANCO860-4	1/2" X 3 3/4" SS ANCHOR KIT (4PC)
11	1	K-CG0824-4L	1/2" CGE BOLT HARDWARE KIT (4)
12	4	K-FC0840-4	1/2" CAP HARDWARE KIT (4 PCS)

1

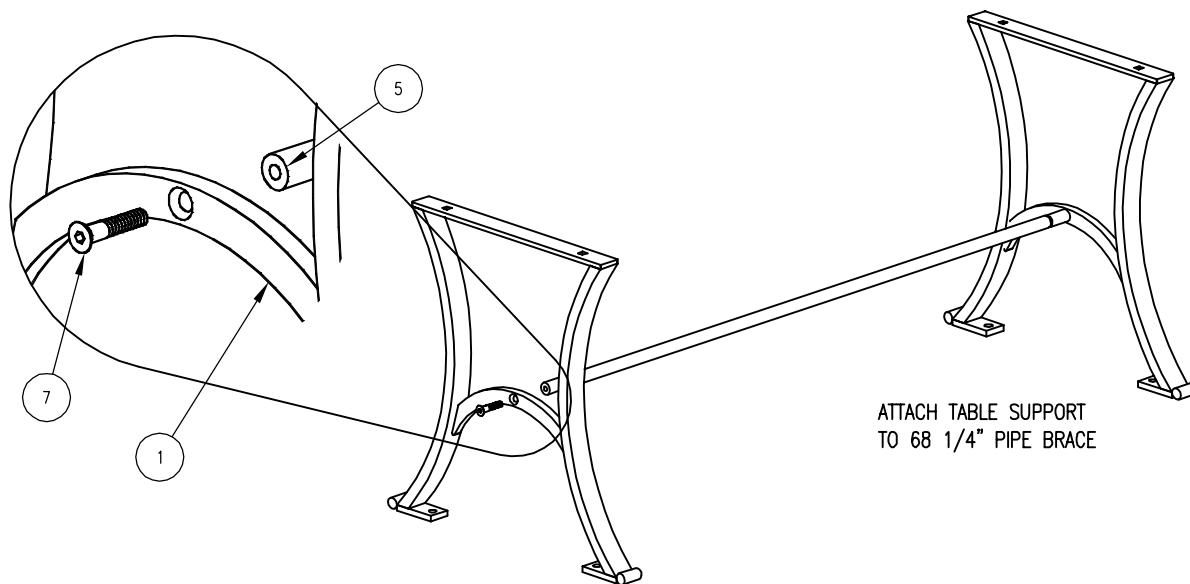

2

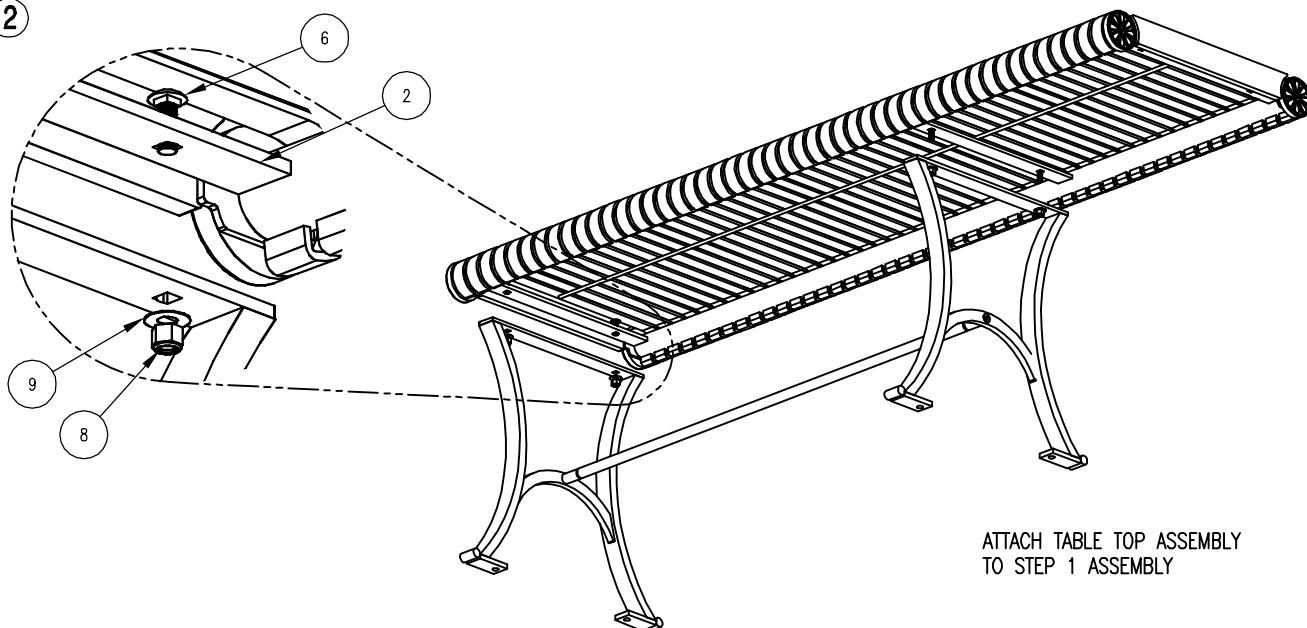

ASSEMBLY INSTRUCTIONS

DATE DRAWN : 11/6/13
 DRAWN BY : JSB
 DATE REV. : 00/00/00
 REV. BY : XXX

REV. A

DRAWING NUMBER

443-558-1/S-2

SHEET 2 OF 3

3

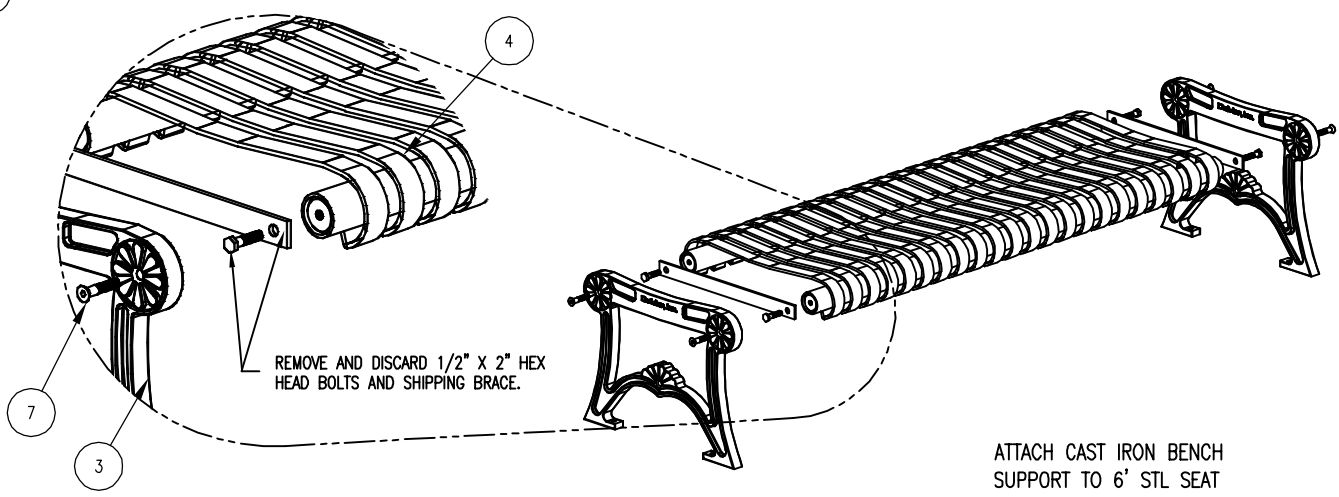

3A



PLACE SEAT ASSEMBLY ON WORK SURFACE ALLOWING ACCESS TO ENDS. PLACE RATCHET STRAP AROUND SEAT ASSEMBLY AS SHOWN ABOVE.

3B



TIGHTEN STRAP UNTIL SHIPPING BRACKET BECOMES LOOSE. THEN REMOVE AND DISCARD BOLTS & SHIPPING BRACKET.

3C



ATTACH CAST SUPPORT TO SEAT ASSEMBLY. IF HOLES IN CASTING DO NOT ALIGN WITH THE SEAT ASSEMBLY, ADJUST BY USING THE RATCHET STRAP.

3D



TIGHTEN HARDWARE THEN REMOVE RATCHET STRAP AND REPEAT THIS PROCEDURE ON THE OTHER END OF BENCH.

4

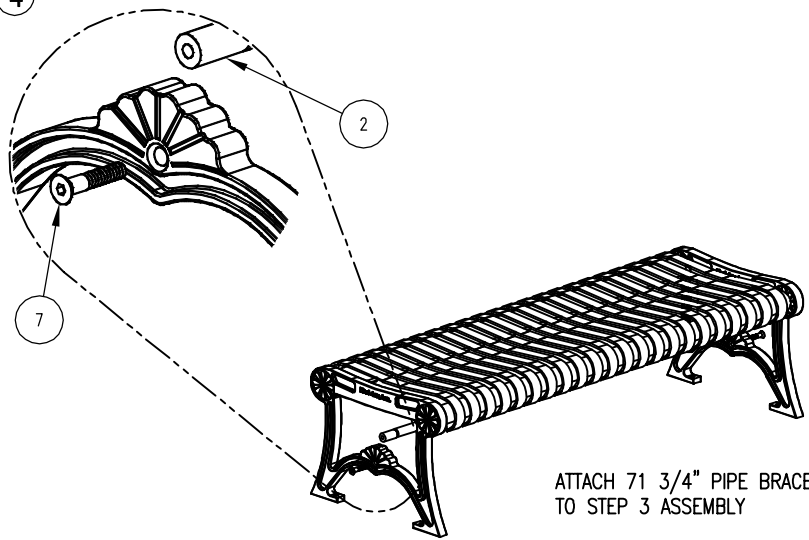

ASSEMBLY INSTRUCTIONS

DATE DRAWN : 11/6/13
 DRAWN BY : JSB
 DATE REV. : 00/00/00
 REV. BY : XXX

REV. A

DRAWING NUMBER

443-558-1/S-2

SHEET 3 OF 3