

SURFACE MOUNT PLATE DETAIL

NOTES

- 1.) ALL STL. MEMBERS COATED W/ ZINC RICH EPOXY THEN FINISHED W/ POLYESTER POWDER COATING.
- 2.) ALL WOOD MEMBERS TREATED W/ CLEAR PRESERVATIVE.
- 3.) 1/2" X 3 3/4" EXPANSION ANCHOR BOLTS PROVIDED.
- 4.) (2) SURFACE MOUNT PLATES PROVIDED ( SEE DETAIL ).

PARTS LIST

ITEM	QTY	PART NO	DESCRIPTION
1	2	0-275-00-09/S-2	1/2" THK STL SURFACE MOUNT PLATE
2	1	0-275-60	6' BENCH ASSEMBLY, WOOD
3	2	1-12-074	1/2" X 1 1/2" SS FLT SKT HD CAP

KITS PROVIDED

ITEM	QTY	PART NO	DESCRIPTION
4	1	K-ANC0860-4	1/2" X 3 3/4" SS ANCHOR KIT (4PC)
5	1	K-FC0824-2	1/2" CAP HARDWARE KIT (2 PCS)

NOTES:

- 1.) DURING ASSEMBLY PROCEDURE;  
DO NOT COMPLETELY TIGHTEN HARDWARE.
- 2.) THE ACTUAL PARTS WILL NOT BE NUMBERED.  
NUMBERS ONLY APPLY TO DRAWING.
- 3.) UPON COMPLETION OF ASSEMBLY SQUARE  
ALL COMPONENTS THEN TIGHTEN ALL HARDWARE.
- 4.) MOUNT AND ANCHOR AS SPECIFIED.

TOOLS REQ'D

- 5/16" ALLEN WRENCH
- 9/16" WRENCH
- 3/4" WRENCH
- 1/2" MASONRY DRILL BIT
- DRILL

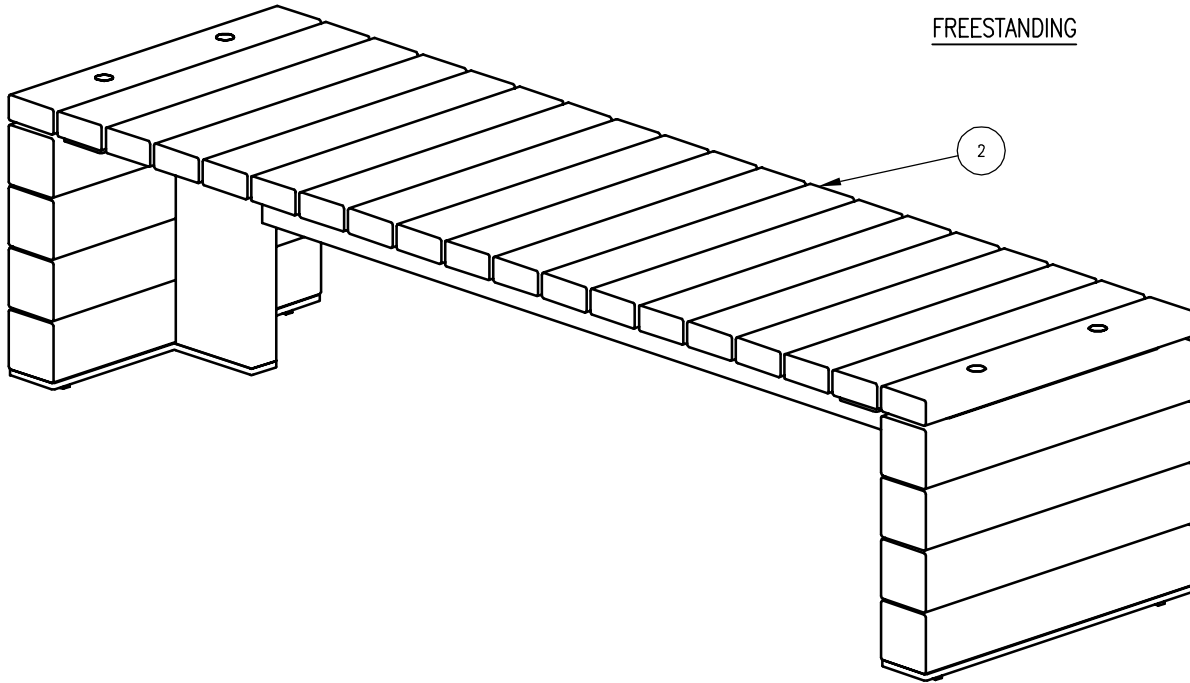

FREESTANDING

SURFACE MOUNT PLATE INSTALLATION

