

NOTES:

- 1.) ALL STL. MEMBERS COATED W/ ZINC RICH EPOXY THEN FINISHED W/ POLYESTER POWDER COATING.
- 2.) BENCH IS SHIPPED UNASSEMBLED.
- 3.) 1/2" X 3 3/4" EXPANSION ANCHOR BOLTS PROVIDED.



BENCH

DATE DRAWN : 8/28/14
 DRAWN BY : JSB
 DATE REV. : 00/00/00
 REV. BY : XXX

REV.
 A

DRAWING
 NUMBER

R120-120-6

SHEET
 1 OF 2

NOTES:

- 1.) DURING ASSEMBLY PROCEDURE; DO NOT COMPLETELY TIGHTEN HARDWARE.
- 2.) THE ACTUAL PARTS WILL NOT BE NUMBERED. NUMBERS ONLY APPLY TO DRAWING.
- 3.) UPON COMPLETION OF ASSEMBLY SQUARE ALL COMPONENTS THEN TIGHTEN ALL HARDWARE.
- 4.) MOUNT AND ANCHOR AS SPECIFIED.

TOOLS REQ'D

- 3/4" WRENCH
- 5/16" ALLEN WRENCH
- 1/2" MASONRY DRILL BIT
- DRILL
- RATCHET STRAP (PROVIDED)

PARTS LIST

ITEM	QTY	PART NO	DESCRIPTION
1	2	0-119-00-01	CAST IRON SUPPORT
2	2	0-120-00-02	END PLATE
3	1	0-R92-120-6-1	120" RAD 6' STL BKLS SEAT
4	1	0-R92-120-6-2	120" RAD 6' PIPE BRACE
5	2	1-12-037	1/2" X 3" SS FLT SKT HD CAP SCR
6	4	1-12-065	1/2" X 2 1/2" FLT SKT HD CAP SCR
7	4	1-12-074	1/2" X 1 1/2" SS FLT SKT HD CAP
8	4	1-20-018	1/2" SS THIN NYLON LOCKNUT
9	4	1-22-015	1/2" SS FLAT WASHER

KITS PROVIDED

ITEM	QTY	PART NO	DESCRIPTION
10	1	K-119	119 SERIES HARDWARE KIT
11	1	K-ANC0860-4	1/2" X 3 3/4" SS ANCHOR KIT (4PC)

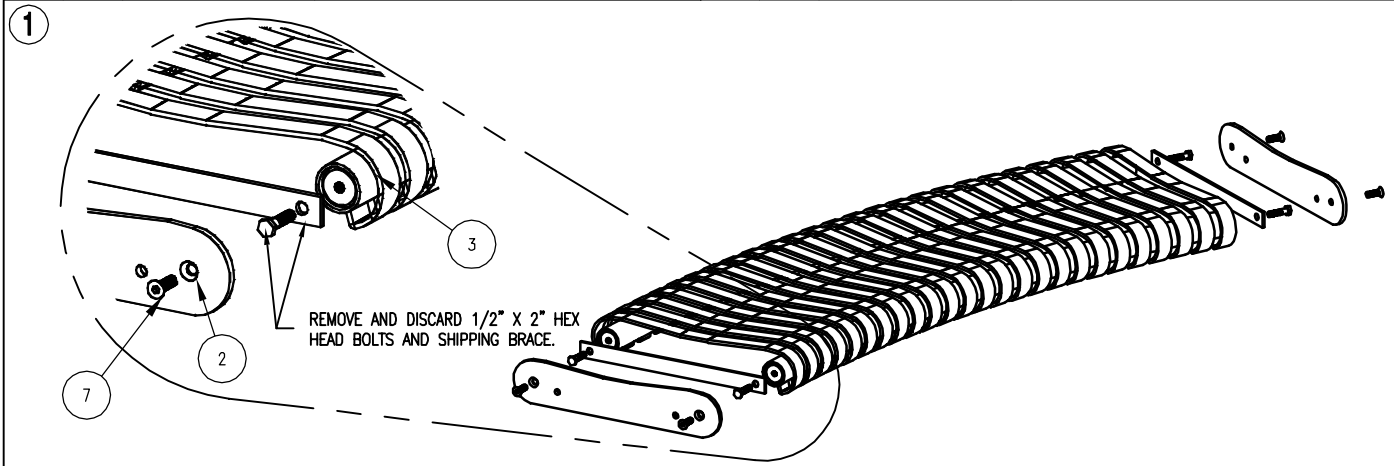

1A

PLACE SEAT ASSEMBLY ON WORK SURFACE ALLOWING ACCESS TO ENDS. PLACE RATCHET STRAP AROUND SEAT ASSEMBLY AS SHOWN ABOVE.

1B

TIGHTEN STRAP UNTIL SHIPPING BRACKET BECOMES LOOSE. THEN REMOVE AND DISCARD BOLTS & SHIPPING BRACKET.

1C

ATTACH SEAT END PLATE TO SEAT ASSEMBLY. IF HOLES IN PLATE DO NOT ALIGN WITH THE SEAT ASSEMBLY, ADJUST BY USING THE RATCHET STRAP.

1D

TIGHTEN HARDWARE THEN REMOVE RATCHET STRAP AND REPEAT THIS PROCEDURE ON THE OTHER END OF BENCH.

