

NOTES

- 1.) ALL STL. MEMBERS COATED W/ ZINC RICH EPOXY THEN FINISHED W/ POLYESTER POWDER COATING.
- 2.) 1/2" X 3 3/4" EXPANSION ANCHOR BOLTS PROVIDED.

PARTS LIST

ITEM	QTY	PART NO	DESCRIPTION
1	2	0-460-60-03	71 3/4" ALUM EXTRUSION
2	3	0-460-60VS-01	10 GA STL PLATE
3	1	0-461-00L-01	LEFT BKLS BENCH SUPPORT
4	1	0-461-00R-01	RIGHT BKLS BENCH SUPPORT
5	4	1-12-053	5/16" X 1 1/2" SS BTN SKT HD CAP SCR

KITS PROVIDED

ITEM	QTY	PART NO	DESCRIPTION
6	1	K-ANC0860-4	1/2" X 3 3/4" SS ANCHOR KIT (4PC)
7	1	K-BC0524-4	5/16" CAP HARDWARE KIT (4PC)

NOTES:

- 1.) DURING ASSEMBLY PROCEDURE; DO NOT COMPLETELY TIGHTEN HARDWARE.
- 2.) THE ACTUAL PARTS WILL NOT BE NUMBERED. NUMBERS ONLY APPLY TO DRAWING.
- 3.) UPON COMPLETION OF ASSEMBLY SQUARE ALL COMPONENTS THEN TIGHTEN ALL HARDWARE.
- 4.) MOUNT AND ANCHOR AS SPECIFIED.

TOOLS REQ'D

- 3/4" WRENCH
 3/16" ALLEN WRENCH
 1/2" MASONRY DRILL BIT
 DRILL

- ① ATTACH ALUM. EXTRUSION AS SHOWN, TO LEFT & RIGHT BENCH SUPPORTS, ENSURE PINS ARE IN "L" SLOTS.

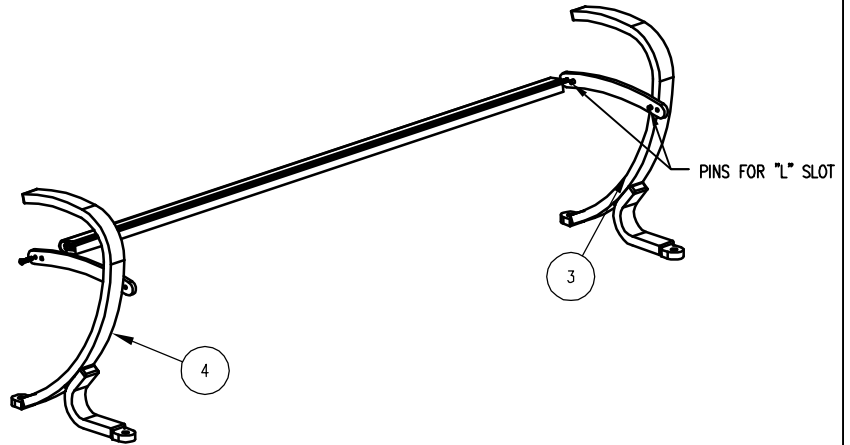
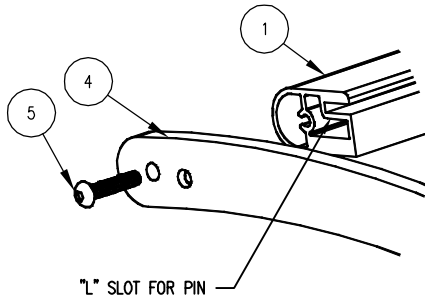

- ② INSERT 10 GA STL. PLATES INTO STEP 1, USING SLOT ON ALUM. EXTRUSION.
 NOTE: RIGHT BENCH SUPPORT NOT SHOWN FOR CLARITY.

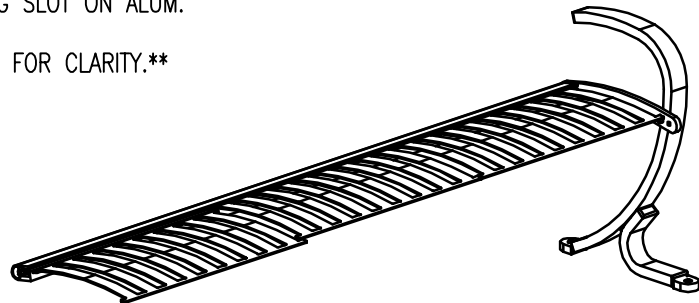
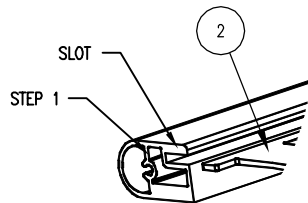

- ③ ATTACH REMAINING ALUM. EXTRUSION TO SUPPORTS, AS IN STEP 1.

