

NOTES

- 1.) ALL STL. MEMBERS COATED W/ ZINC RICH EPOXY THEN FINISHED W/ POLYESTER POWDER COATING.
- 2.) 1/2" X 3 3/4" EXPANSION ANCHOR BOLTS PROVIDED.

PARTS LIST

ITEM	QTY	PART NO	DESCRIPTION
1	1	0-126-05	TABLE TOP WITH BOLT TABS
2	3	0-462-00-01	STL TABLE SUPPORT FRAME, 1 SEAT
3	1	0-462-00-02	3/8" THK STL BOLT PLATE
4	6	0-462-00-04	15 3/4" ALUM EXTRUSION
5	1	0-462-00-07	STL TABLE SUPPORT FRAME, NO SEAT
6	3	0-462-00L-03	LEFT STL BKLS SEAT FRAME
7	3	0-462-00R-03	RIGHT STL BKLS SEAT FRAME
8	3	0-462-VS-01	10 GA 12 3/8" X 15 3/4" STL PLATE
9	4	1-11-003	3/8" X 1 1/2" SS CGE BOLT
10	14	1-11-042	1/2" X 1 1/2" SS CGE BOLT
11	12	1-12-053	5/16" X 1 1/2" SS BTN SKT HD CAP SCR
12	4	1-20-007	3/8" SS NYLON LOCKNUT
13	14	1-20-015	1/2" SS NYLON LOCKNUT
14	14	1-22-015	1/2" SS FLAT WASHER
15	4	1-22-024	3/8" SS FLAT WASHER

NOTES:

- 1.) DURING ASSEMBLY PROCEDURE; DO NOT COMPLETELY TIGHTEN HARDWARE.
- 2.) THE ACTUAL PARTS WILL NOT BE NUMBERED. NUMBERS ONLY APPLY TO DRAWING.
- 3.) UPON COMPLETION OF ASSEMBLY SQUARE ALL COMPONENTS THEN TIGHTEN ALL HARDWARE.
- 4.) MOUNT AND ANCHOR AS SPECIFIED.

TOOLS REQ'D

- 3/4" WRENCH
- 9/16" WRENCH
- 3/16" ALLEN WRENCH
- 1/2" MASONRY DRILL BIT
- DRILL

KITS PROVIDED

ITEM	QTY	PART NO	DESCRIPTION
16	1	K-ANC0860-4	1/2" X 3 3/4" SS ANCHOR KIT (4PC)
17	3	K-BC0524-4	5/16" CAP HARDWARE KIT (4PC)
18	1	K-CG0624-4L	3/8" CGE BOLT HARDWARE KIT (4PC)
19	1	K-CG0824-2L	1/2" CGE BOLT HARDWARE KIT (2PC)
20	3	K-CG0824-4L	1/2" CGE BOLT HARDWARE KIT (4)

1 ATTACH 4 SUPPORTS TOGETHER.

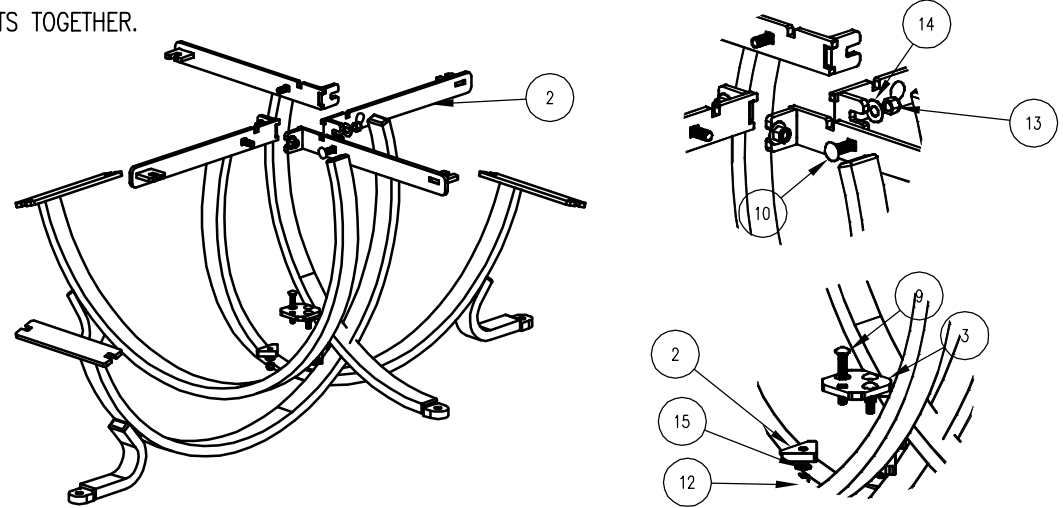

2 ATTACH TABLE TOP TO STEP 1.

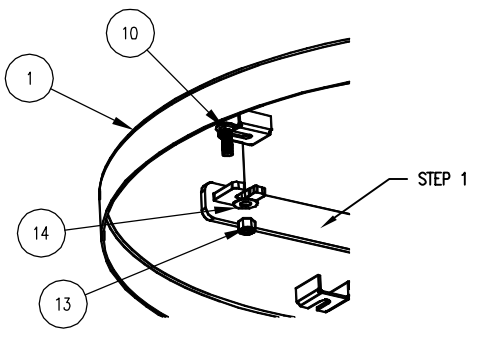

3 ATTACH ALUM. EXTRUSION TO LEFT & RIGHT SEAT FRAMES, ENSURE PINS ARE IN "L" SLOTS. ATTACH TO STEP 1.

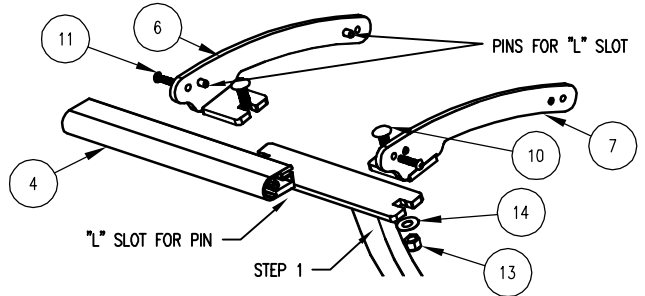

4 INSERT SEAT/BACK INTO STEP 3, USING SLOT ON ALUM. EXTRUSION.

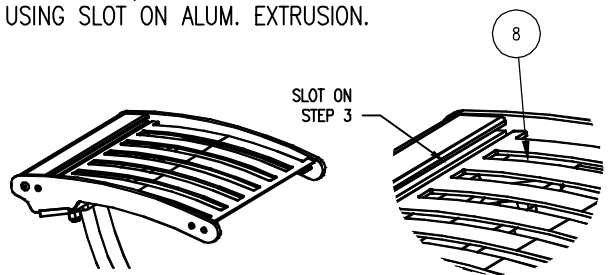

5 ATTACH REMAINING ALUM. EXTRUSIONS TO SEAT FRAMES, AS IN STEP 3.

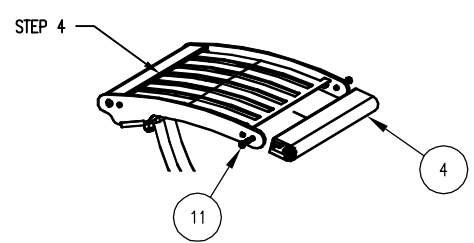

ASSEMBLY INSTRUCTIONS

DATE DRAWN : 04/24/14
 DRAWN BY : RDH
 DATE REV. : 11/9/15
 REV. BY : JSB

REV. B

DRAWING NUMBER

462-30VS

SHEET 2 OF 2