

LENGTH OPTIONS

- 6' BENCH
- 8' BENCH

NOTES

- 1.) ALL STL. MEMBERS COATED W/ ZINC RICH COATING THEN POLYESTER POWDER COATED.
- 2.) BENCH IS SHIPPED UNASSEMBLED.
- 3.) $1/2'' \times 3 \frac{3}{4}''$ EXPANSION ANCHOR BOLTS PROVIDED.

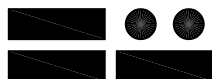

DuMor, inc.

P.O. Box 142 Mifflintown, PA 17059-0142

SCALE :	NONE
DATE DRAWN :	7/2/03
DRAWN BY :	JSB
DATE REV. :	3/20/07
REV. BY :	AWH

TITLE :	BENCH		
REV. :	D	DRAWING NUMBER	160 SERIES
			SHEET 1 OF 2

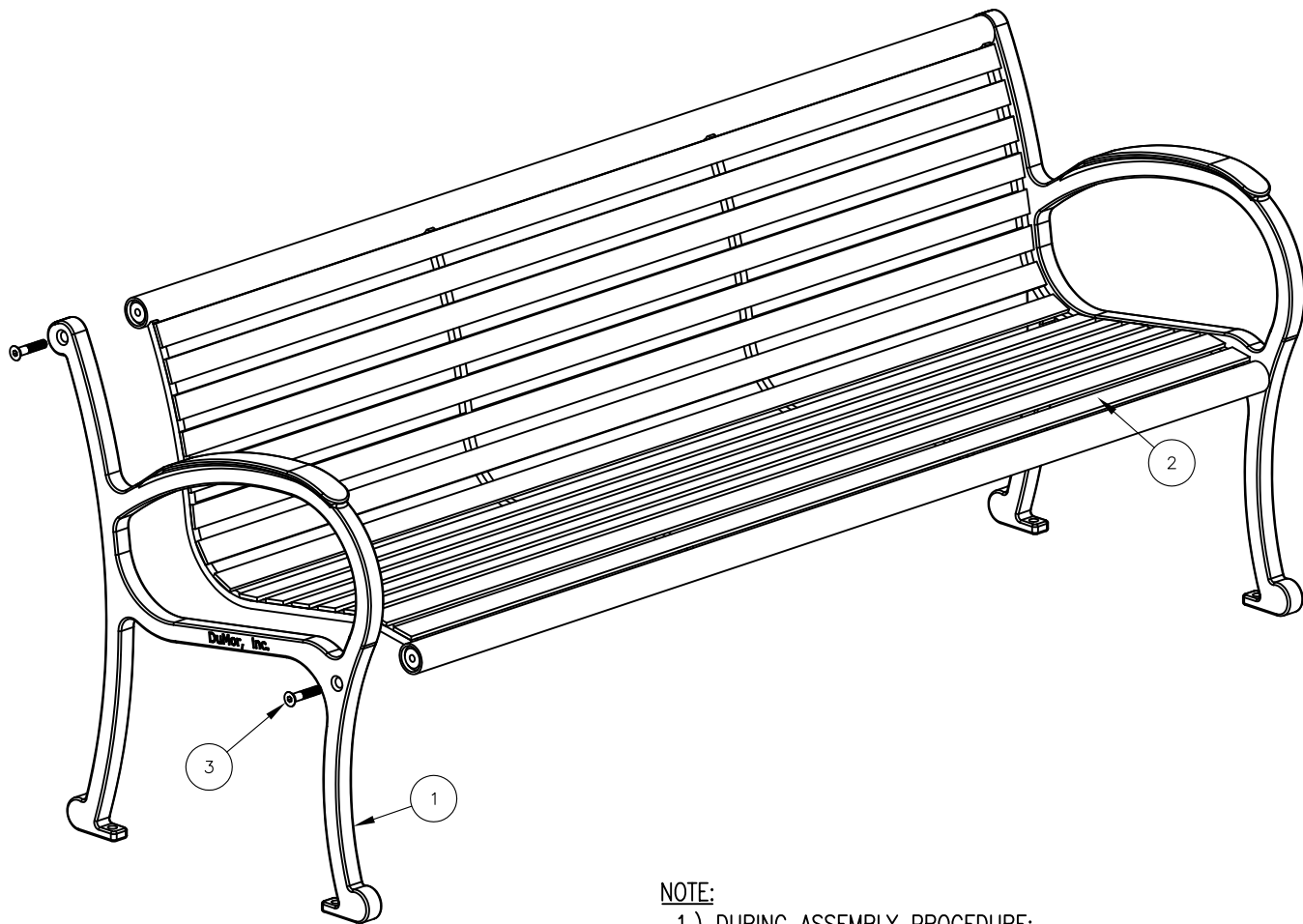

NOTE:

- 1.) DURING ASSEMBLY PROCEDURE;
DO NOT COMPLETELY TIGHTEN HARDWARE.
- 2.) THE ACTUAL PARTS WILL NOT BE NUMBERED;
NUMBERS ONLY APPLY TO DRAWING.

STEP 1:

USE 2 - PCS. CAST IRON BENCH SUPPORT W/ BACK (1)
 1 - PC. 6' ALL STL WELDED SEAT SECTION (2)
 4 - PCS. 1/2" X 2 1/2" FLT. SKT. HD. CAP SCR. (3)
 ATTACH CAST IRON BENCH SUPPORT W/ BACK (1) TO 6' ALL
 STL WELDED SEAT ASSEMBLY (2) USING HARDWARE (3).
 TIGHTEN TO SNUG FIT.

STEP 2:

UPON COMPLETION OF BENCH ASSEMBLY SQUARE ALL
 COMPONENTS THEN TIGHTEN ALL HARDWARE.

STEP 3:

MOUNT AND ANCHOR AS SPECIFIED.

ITEM	QTY	PART NO	DESCRIPTION
1	2	0-160-00-01	CAST IRON BENCH SUPPORT FOR BACKREST
2	1	0-160-60-02	6' STL SEAT
3	4	1-12-065	1/2" X 2 1/2" FLT SKT HD CAP SCR

 DuMor, inc. P.O. Box 142 Mifflintown, PA 17059-0142	SCALE :	NONE	TITLE :		BENCH ASSEMBLY	
	DATE DRAWN :	7/2/03	REV.	DRAWING NUMBER	160 SERIES	SHEET
	DRAWN BY :	JSB	D			
	DATE REV. :	3/20/07				
REV. BY :	AWH				2 OF 2	