

NOTES

- 1.) ALL STL. MEMBERS COATED W/ ZINC RICH EPOXY THEN FINISHED W/ POLYESTER POWDER COATING.
- 2.) 1/2" X 3 3/4" EXPANSION ANCHOR BOLTS PROVIDED.

SLAT OPTIONS

- "CEDAR" RECYCLED PLASTIC
- "GREY" RECYCLED PLASTIC
- "REDWOOD" RECYCLED PLASTIC
- "WALNUT" RECYCLED PLASTIC
- OTHER \_\_\_\_\_



BENCH

DATE DRAWN : 11/03/15  
 DRAWN BY : RDH  
 DATE REV. :  
 REV. BY :

REV.  
A

DRAWING  
NUMBER

490-80PL

SHEET  
1 OF 3

PARTS LIST

ITEM	QTY	PART NO	DESCRIPTION
1	18	0-143-40PL-01	2" X 3" X 47" INT'R SLAT, PLASTIC
2	4	0-143-40PL-02	2" X 3" X 47" EDGE SLAT, PLASTIC
3	4	0-16-40-06	47" SEAT BRACE
4	3	0-490-00-01	CAST ALUM BENCH SUPPORT W/ BACK
5	2	0-57-00-03	CENTER CONTOUR STRAP
6	3	0-57-00-05	END CONTOUR STRAP
7	1	0-57-00-06	END STRAP FOR CTR SUPPORT
8	1	0-57-40-04	47 3/4" PIPE BRACE
9	1	0-57-40-05	47 3/4" PIPE BRACE WITH STUD
10	2	1-12-040	1/2" X 5 1/2" SS HEX HD CAP SCR
11	6	1-12-065	1/2" X 2 1/2" FLT SKT HD CAP SCR
12	12	1-12-116	5/16" X 1" SS BTN SKT HD CAP SCR
13	66	1-13-023	5/16" X 1 1/2" SS BTN SKT HD CAP SCR
14	12	1-20-016	5/16" SS NYLON LOCKNUT
15	82	1-22-017	5/16" SS FLAT WASHER

NOTE:

- 1.) DURING ASSEMBLY PROCEDURE;  
DO NOT COMPLETELY TIGHTEN HARDWARE.
- 2.) THE ACTUAL PARTS WILL NOT BE NUMBERED.  
NUMBERS ONLY APPLY TO DRAWING.
- 3.) UPON COMPLETION OF ASSEMBLY SQUARE  
ALL COMPONENTS THEN TIGHTEN ALL HARDWARE.
- 4.) MOUNT AND ANCHOR AS SPECIFIED.

TOOLS REQ'D

- 3/4" WRENCH
- 9/16 WRENCH
- 1/4" ALLEN WRENCH
- 3/8" DRILL BIT
- 1/2" MASONRY DRILL BIT
- DRILL

KITS PROVIDED

ITEM	QTY	PART NO	DESCRIPTION
16	2	K-143-40	143-40 SER HARDWARE KIT
17	2	K-ANC0860-3	1/2" X 3 3/4" SS ANCHOR KIT (3PCS)
18	1	K-FC0840-6	1/2" CAP HARDWARE KIT (6PC)
19	1	K-HC0888-2	1/2" CAP HARDWARE KIT (2PC)

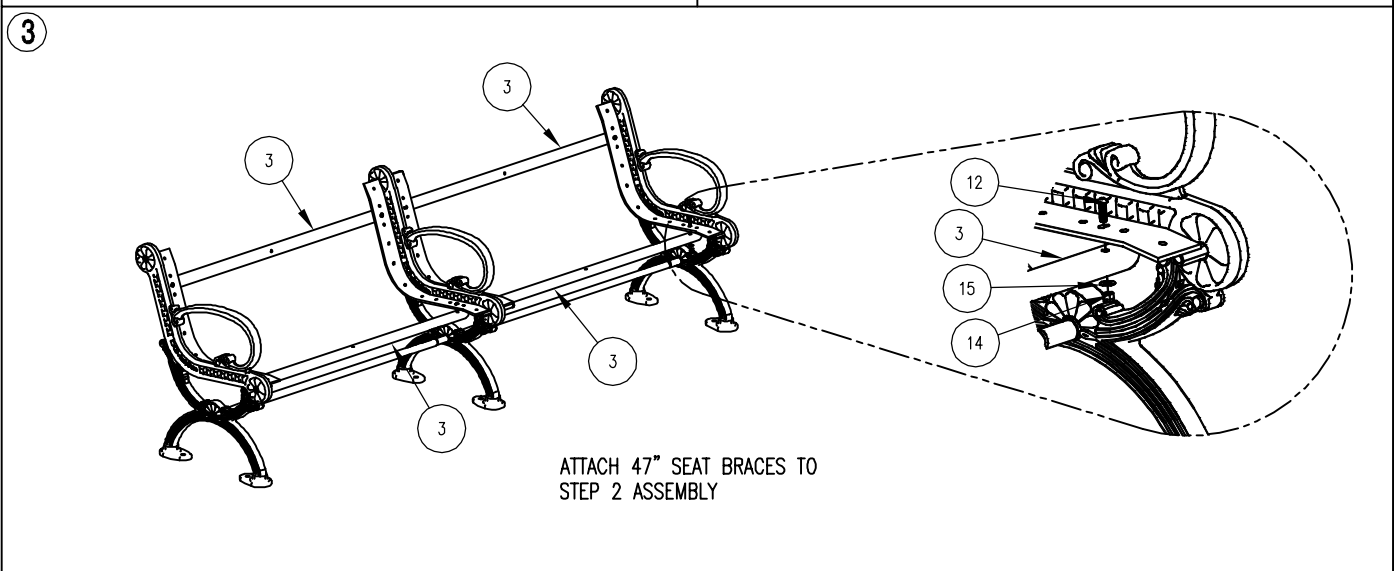
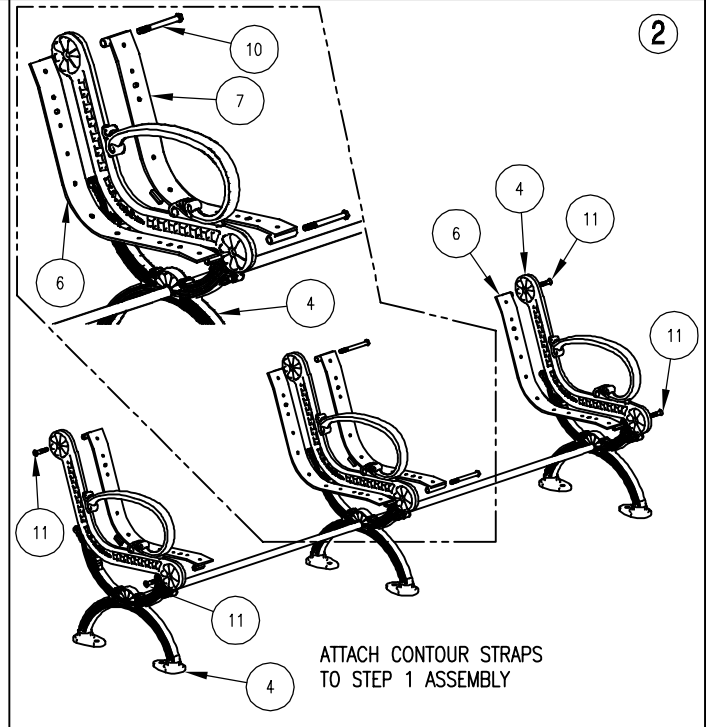
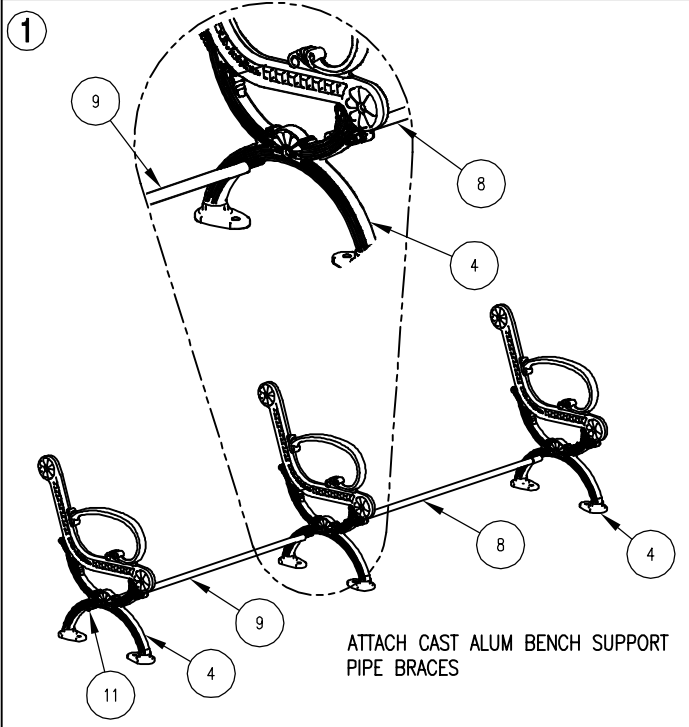

ASSEMBLY INSTRUCTIONS

DATE DRAWN : 11/03/15  
 DRAWN BY : RDH  
 DATE REV. :  
 REV. BY :

REV. A

DRAWING NUMBER

490-80PL

SHEET 2 OF 3

4

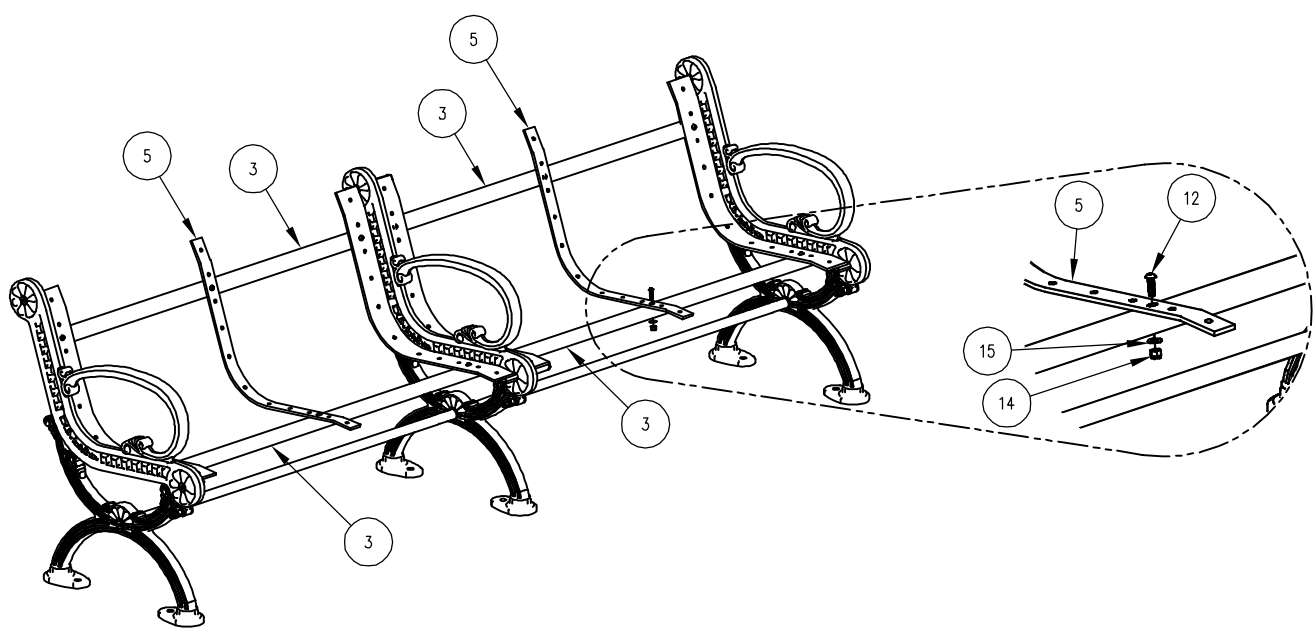

ATTACH CENTER CONTOUR STRAPS TO STEP 3 ASSEMBLY.

5

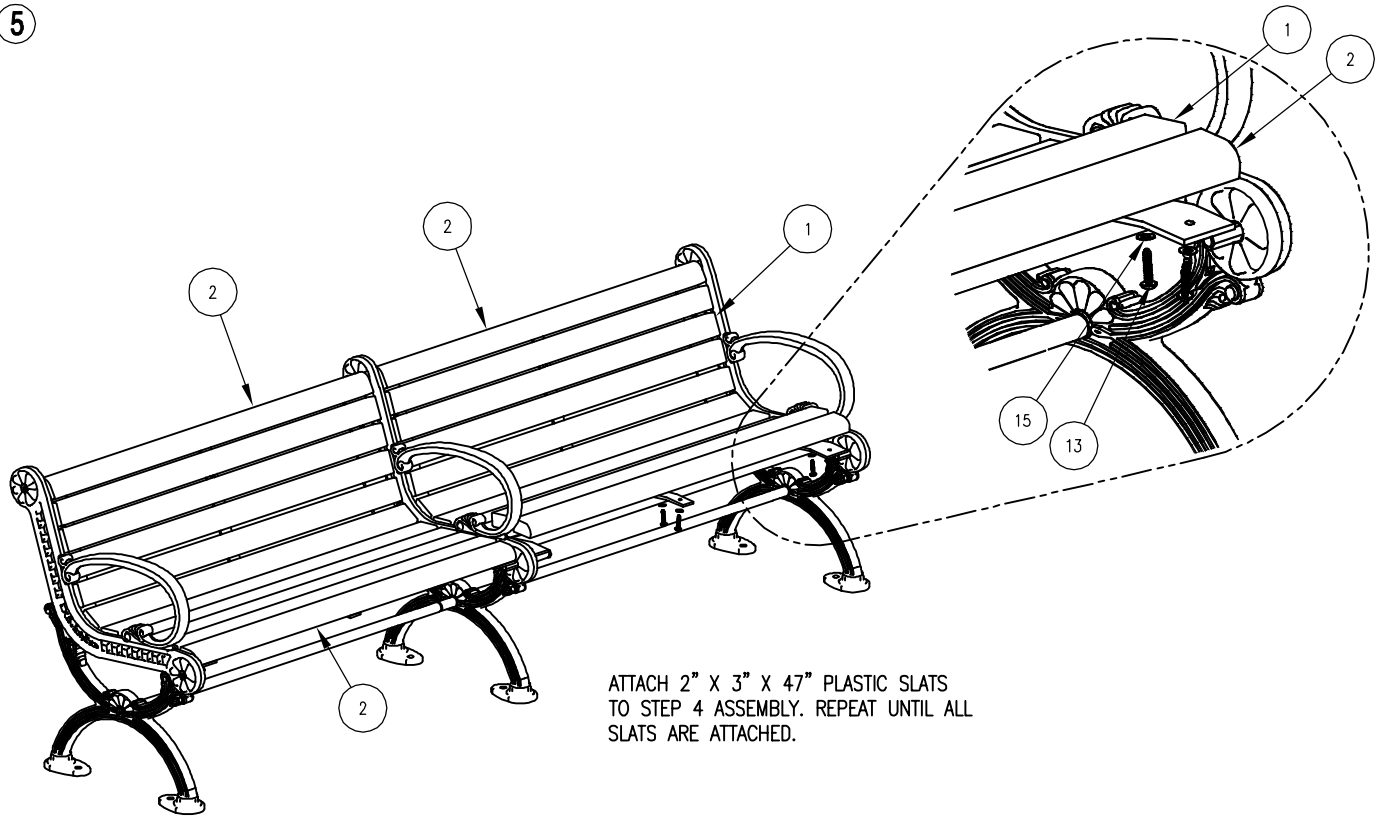

ATTACH 2" X 3" X 47" PLASTIC SLATS TO STEP 4 ASSEMBLY. REPEAT UNTIL ALL SLATS ARE ATTACHED.



ASSEMBLY INSTRUCTIONS

DATE DRAWN : 11/03/15  
 DRAWN BY : RDH  
 DATE REV. :  
 REV. BY :

REV. A

DRAWING NUMBER

490-80PL

SHEET 3 OF 3