

LENGTH OPTIONS

- 6' BENCH
- 8' BENCH

NOTES

- 1.) ALL STL. MEMBERS COATED W/ ZINC RICH COATING THEN POLYESTER POWDER COATED.
- 2.) BENCH IS SHIPPED UNASSEMBLED.
- 3.) 1/2" X 3 3/4" EXPANSION ANCHOR BOLTS PROVIDED.

  
**DuMor, inc.**  
 P.O. Box 142 Mifflintown, PA 17059-0142

SCALE : NONE  
 DATE DRAWN : 9/20/06  
 DRAWN BY : AWH  
 DATE REV. :  
 REV. BY :

TITLE : BENCH  
 REV. A  
 DRAWING NUMBER 168 SERIES

SHEET 1 OF 2

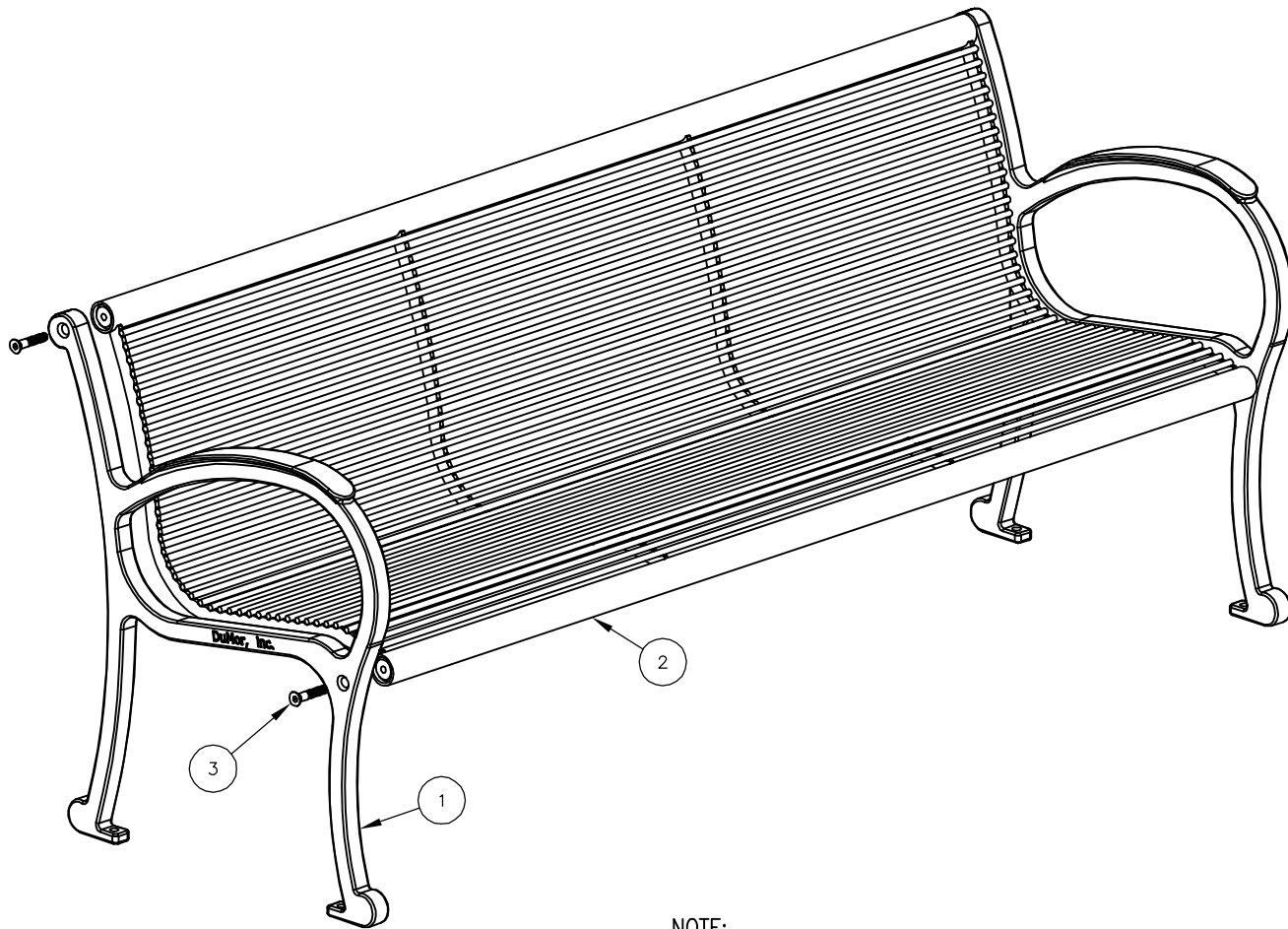

**NOTE:**

- 1.) DURING ASSEMBLY PROCEDURE;  
DO NOT COMPLETELY TIGHTEN HARDWARE.
- 2.) THE ACTUAL PARTS WILL NOT BE NUMBERED;  
NUMBERS ONLY APPLY TO DRAWING.

**STEP 1:**

USE 2 - PCS. CAST IRON BENCH SUPPORT W/ BACK ( 1 )  
 1 - PC. 6' ALL STL WELDED SEAT SECTION ( 2 )  
 4 - PCS. 1/2" X 2 1/2" FLT. SKT. HD. CAP SCR. ( 3 )  
 ATTACH CAST IRON BENCH SUPPORT W/ BACK ( 1 ) TO 6' ALL  
 STL WELDED SEAT ASSEMBLY ( 2 ) USING HARDWARE ( 3 ).  
 TIGHTEN TO SNUG FIT.

**STEP 2:**

UPON COMPLETION OF BENCH ASSEMBLY SQUARE ALL  
 COMPONENTS THEN TIGHTEN ALL HARDWARE.

**STEP 3:**

MOUNT AND ANCHOR AS SPECIFIED.

ITEM	QTY	PART NO	DESCRIPTION
1	2	0-160-00-01	CAST IRON BENCH SUPPORT FOR BACKREST
2	1	0-168-60-01	6' STL SEAT
3	4	1-12-065	1/2" X 2 1/2" FLT SKT HD CAP SCR

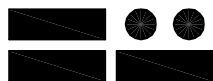

**DuMor, inc.**

P.O. Box 142 Mifflintown, PA 17059-0142

SCALE : NONE  
 DATE DRAWN : 9/20/06  
 DRAWN BY : AWH  
 DATE REV. :  
 REV. BY :

TITLE : BENCH ASSEMBLY

REV. A  
 DRAWING NUMBER 168 SERIES

SHEET 2 OF 2