

NOTES

- 1.) ALL STL. MEMBERS COATED W/ ZINC RICH EPOXY THEN FINISHED W/ POLYESTER POWDER COATING.
- 2.) $1 \frac{1}{2}$ " X $3 \frac{3}{4}$ " EXPANSION ANCHOR BOLTS PROVIDED.

PARTS LIST

ITEM	QTY	PART NO	DESCRIPTION
1	1	0-162-60-01	6' STL SEAT
2	2	0-490-00-01	CAST ALUM BENCH SUPPORT W/ BACK
3	1	0-57-60-04	71 3/4" PIPE BRACE
4	6	1-12-065	1/2" X 2 1/2" FLT SKT HD CAP SCR
5	4	1-20-018	1/2" SS THIN NYLON LOCKNUT
6	4	1-22-015	1/2" SS FLAT WASHER

KITS PROVIDED

ITEM	QTY	PART NO	DESCRIPTION
7	1	K-ANCO860-4	1/2" X 3 3/4" SS ANCHOR KIT (4PC)
8	1	K-FC0840-6	1/2" CAP HARDWARE KIT (6PC)
9	1	K-TLNUT08-4	1/2" THIN LOCK NUT HARDWARE KIT (4PC)

NOTES:

- 1.) DURING ASSEMBLY PROCEDURE;
DO NOT COMPLETELY TIGHTEN HARDWARE.
- 2.) THE ACTUAL PARTS WILL NOT BE NUMBERED.
NUMBERS ONLY APPLY TO DRAWING.
- 3.) UPON COMPLETION OF ASSEMBLY SQUARE
ALL COMPONENTS THEN TIGHTEN ALL HARDWARE.
- 4.) MOUNT AND ANCHOR AS SPECIFIED.

TOOLS REQ'D

- 3/4" WRENCH
5/16" ALLEN WRENCH
1/2" MASONRY DRILL BIT
DRILL

① ATTACH PIPE BRACE TO CAST ALUM BENCH SUPPORTS.

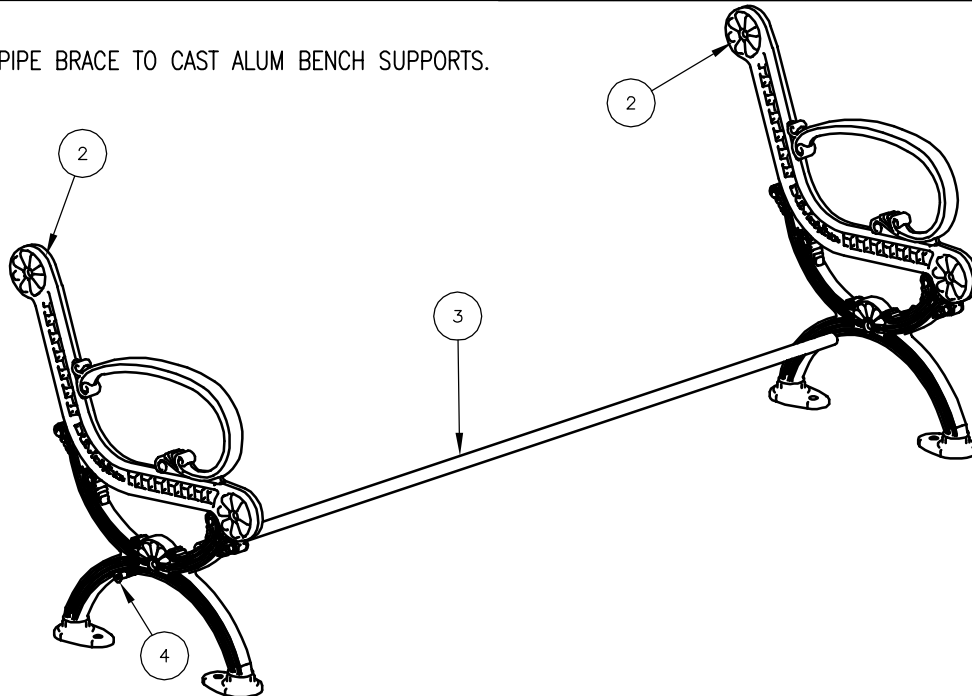

② ATTACH STL SEAT TO END SUPPORTS.

