

SLOTTED PERF LAYOUT

NOTES

- 1.) ALL STL. MEMBERS COATED W/ ZINC RICH COATING THEN POLYESTER POWDER COATED.
- 2.) BENCH IS SHIPPED UNASSEMBLED.
- 3.) 1/2" X 3 3/4" EXPANSION ANCHOR BOLTS PROVIDED.

LENGTH OPTIONS

- 6' BENCH
- 8' BENCH

DuMor, inc.
 P.O. Box 142 Mifflintown, PA 17059-0142

| | |
|--------------|---------|
| SCALE : | NONE |
| DATE DRAWN : | 9/28/06 |
| DRAWN BY : | AWH |
| DATE REV. : | |
| REV. BY : | |

| | | | |
|---------|-------|----------------|-----------------|
| TITLE : | BENCH | | |
| REV. : | A | DRAWING NUMBER | 169 SERIES |
| | | | SHEET 1 OF 2 |

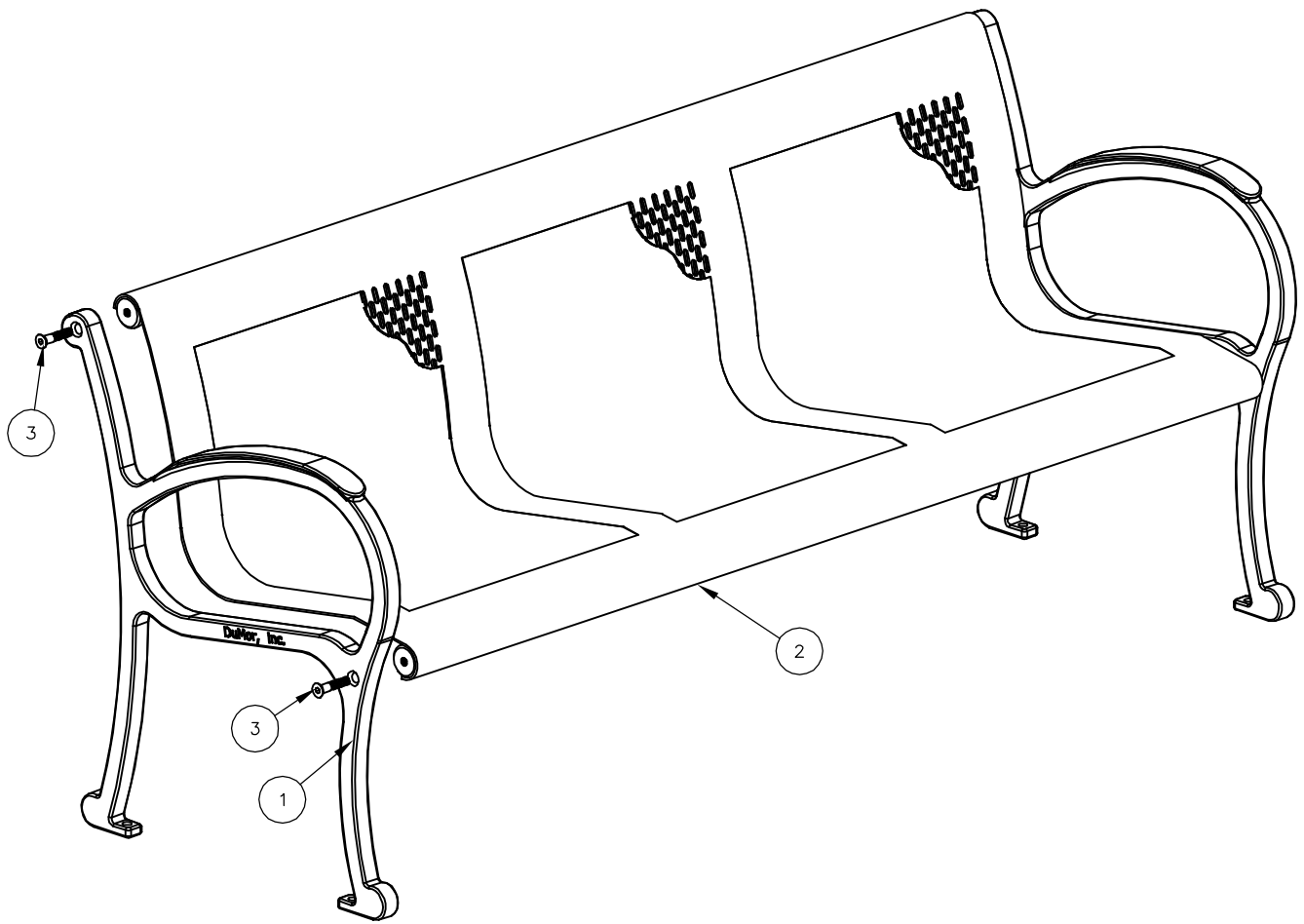

STEP 1:

- USE 2 - PCS. CAST IRON BENCH SUPPORT FOR BACKREST (1)
 - 1 - PC. 6' STL PERF SEAT (2)
 - 4 - PCS. 1/2" X 2 1/2" FLT. SKT. HD. CAP SCR. (3)
- ATTACH 6' STL PERF SEAT (2) TO CAST IRON BENCH SUPPORT FOR BACKREST (1) USING HARDWARE (3)

NOTE:

- 1.) DURING ASSEMBLY PROCEDURE; DO NOT COMPLETELY TIGHTEN HARDWARE.
- 2.) THE ACTUAL PARTS WILL NOT BE NUMBERED: NUMBERS ONLY APPLY TO DRAWING.

STEP 2:

UPON COMPLETION OF BENCH ASSEMBLY SQUARE ALL COMPONENTS THEN TIGHTEN ALL HARDWARE.

STEP 3:

MOUNT AND ANCHOR AS SPECIFIED.

| ITEM | QTY | PART NO | DESCRIPTION |
|------|-----|-------------|--------------------------------------|
| 1 | 2 | 0-160-00-01 | CAST IRON BENCH SUPPORT FOR BACKREST |
| 2 | 1 | 0-169-60-02 | 6' STL PERF SEAT |
| 3 | 4 | 1-12-065 | 1/2" X 2 1/2" FLT SKT HD CAP SCR |



DuMor, inc.
P.O. Box 142 Mifflintown, PA 17059-0142

SCALE : NONE
DATE DRAWN : 9/28/06
DRAWN BY : AWH
DATE REV. :
REV. BY :

TITLE : BENCH ASSEMBLY

| | | |
|--------|---------------------------|--------------|
| REV. A | DRAWING NUMBER 169 SERIES | SHEET 2 OF 2 |
|--------|---------------------------|--------------|