

NOTES

- 1.) ALL STL. MEMBERS COATED W/ ZINC RICH EPOXY THEN FINISHED W/ POLYESTER POWDER COATING.
- 2.) 1/2" X 3 3/4" EXPANSION ANCHOR BOLTS PROVIDED.

**DuMor, inc.**  
P.O. Box 142 Mifflintown, PA 17059-0142

SCALE : NONE  
DATE DRAWN : 11/10/10  
DRAWN BY : JSB  
DATE REV. :  
REV. BY :

TITLE : BENCH  
REV. A  
DRAWING NUMBER 194-80

SHEET 1 OF 2

**NOTE:**

- 1.) DURING ASSEMBLY PROCEDURE;  
DO NOT COMPLETELY TIGHTEN HARDWARE.
- 2.) THE ACTUAL PARTS WILL NOT BE NUMBERED;  
NUMBERS ONLY APPLY TO DRAWING.

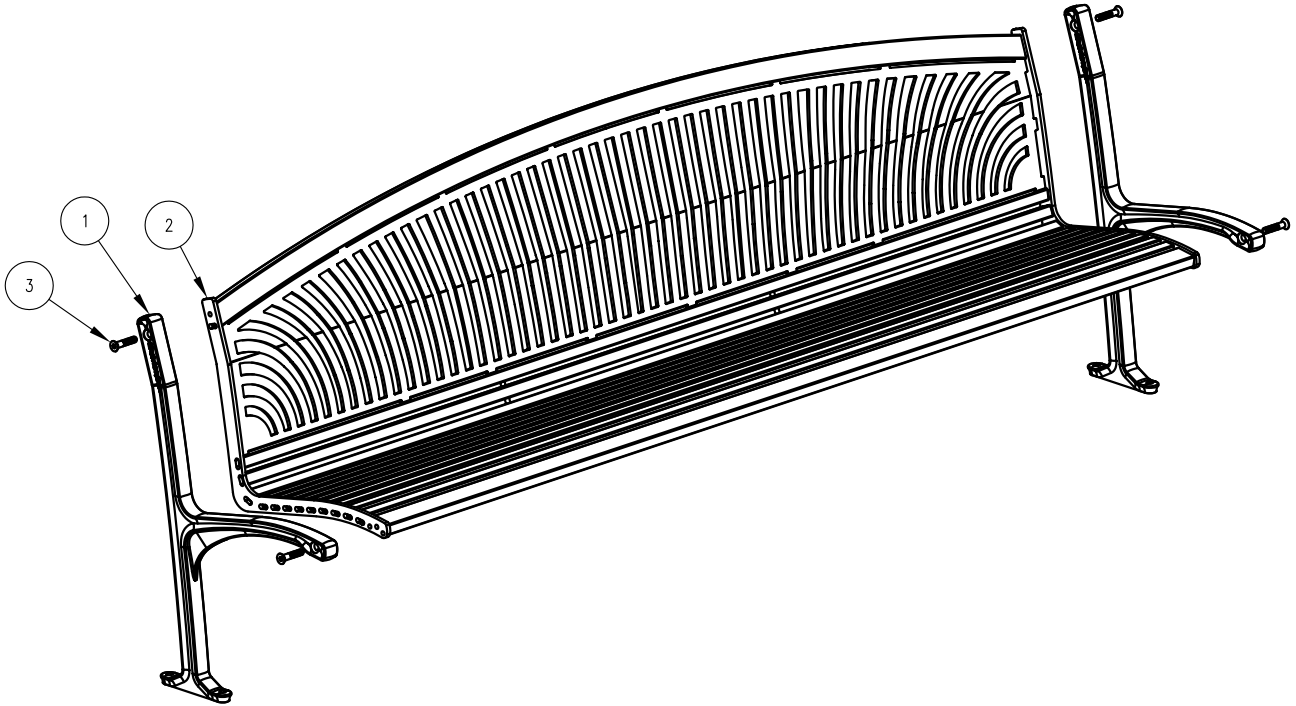

**STEP 1:**

USE 2 - PCS. DUCTILE IRON END SUPPORT ( 1 )  
 1 - PC. 8' STL SEAT ( 2 )  
 4 - PCS. 1/2" X 2 1/2" FLT. SKT. HD. CAP SCR. ( 3 )  
 ATTACH DUCTILE IRON END SUPPORT ( 1 ) TO 6' STL SEAT  
 ( 2 ) USING HARDWARE ( 3 ). TIGHTEN TO SNUG FIT.

**STEP 2:**

UPON COMPLETION OF BENCH ASSEMBLY SQUARE  
 ALL COMPONENTS THEN TIGHTEN ALL HARDWARE.

**STEP 3:**

MOUNT AND ANCHOR AS SPECIFIED.

ITEM	QTY	PART NO	DESCRIPTION
1	2	0-185-00-01	DUCTILE IRON END SUPPORT
2	1	0-194-80-01	8' STL SEAT
3	4	1-12-065	1/2" X 2 1/2" FLT SKT HD CAP SCR

	SCALE :	NONE	TITLE : BENCH ASSEMBLY		
	DATE DRAWN :	11/10/10			
	DRAWN BY :	JSB	REV.	DRAWING NUMBER 194-80	SHEET 2 OF 2
	DATE REV. :		A		
	REV. BY :				